

TREATISE

CORNELIUS CARDEW

THE GALLERY UPSTAIRS PRESS
3100 MAIN STREET
BUFFALO, N. Y. 14214

THE GALLERY UPSTAIRS PRESS • BUFFALO, NEW YORK

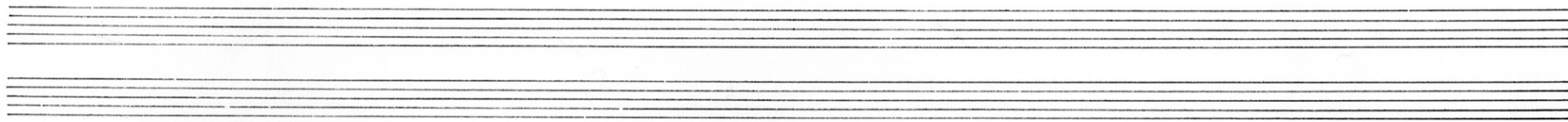
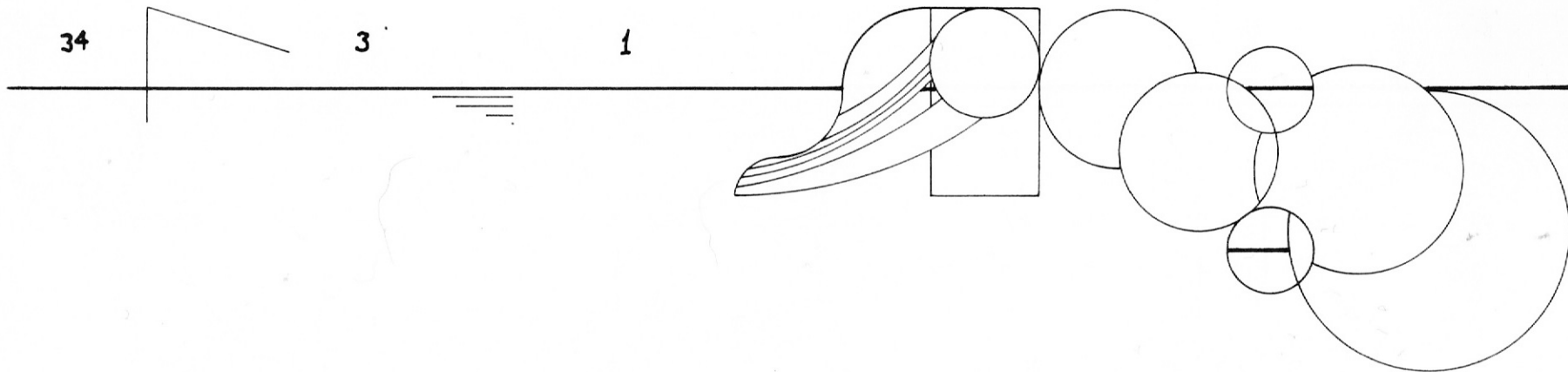

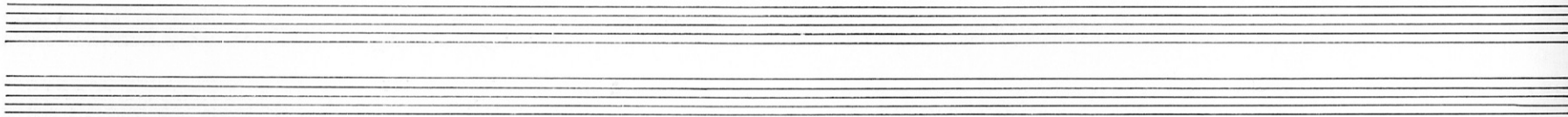
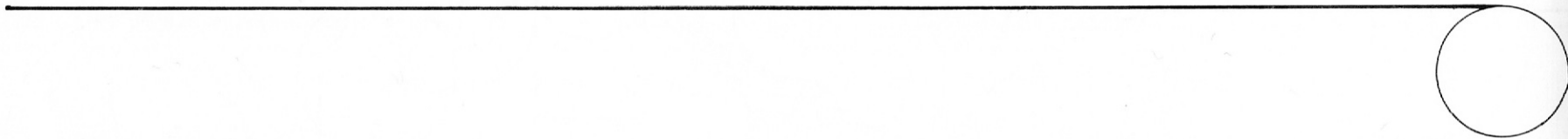

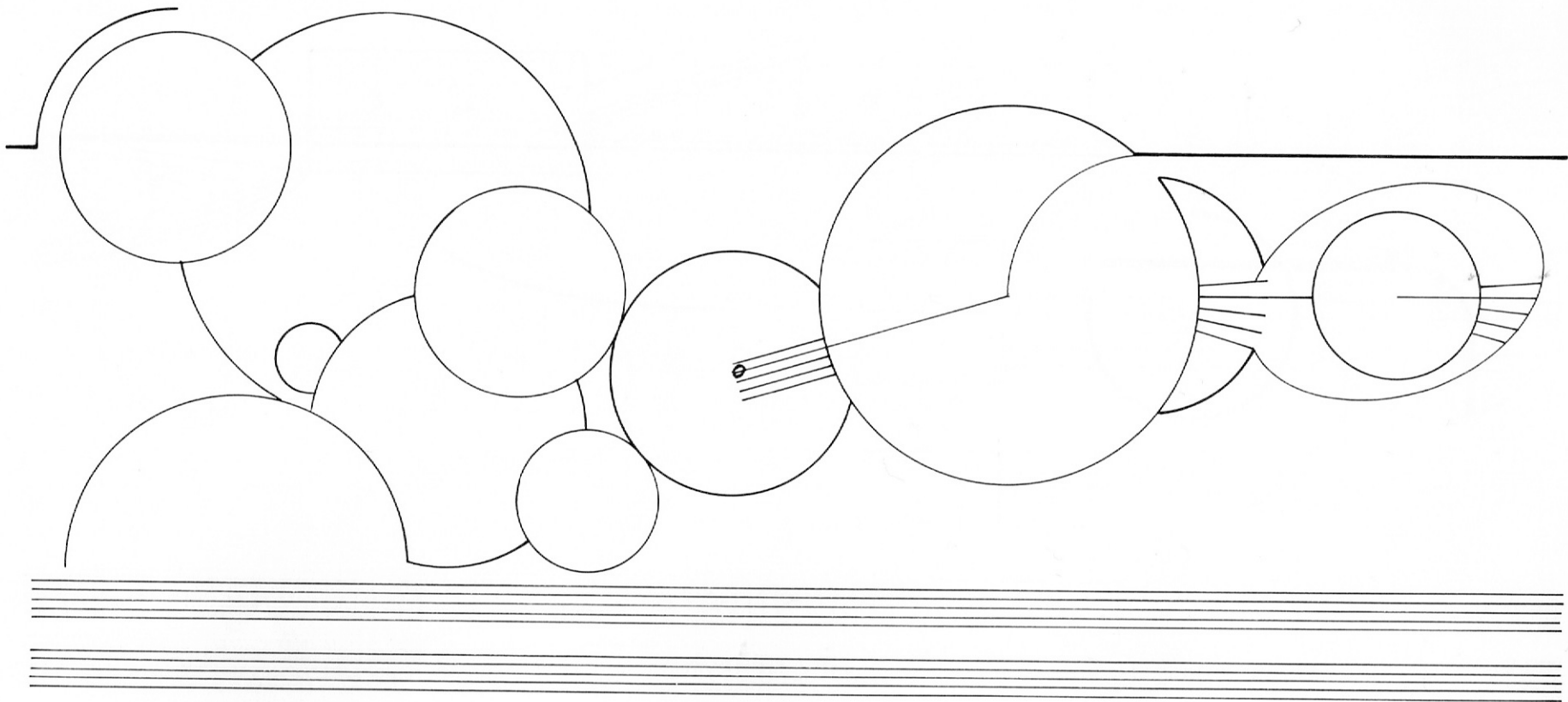

2

8

3

A musical notation diagram. On the left, a bass clef is positioned on a staff. A thick black line starts from the staff, curves upwards, and then continues horizontally to the right. A flat symbol (b) is placed above this horizontal line. Two overlapping circles are drawn around the initial curved portion of the thick line. To the right of the thick line, there are three horizontal lines, each with a bracket underneath it, suggesting a multi-measure rest or a specific rhythmic structure.

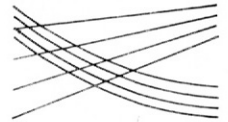

Two sets of empty musical staves, each consisting of five horizontal lines, positioned at the bottom of the page.

1



4



3

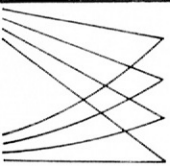
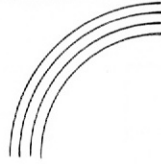

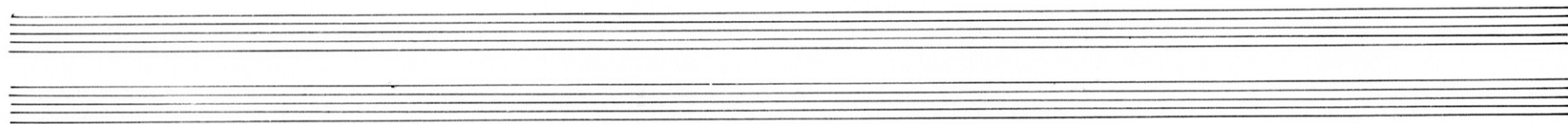
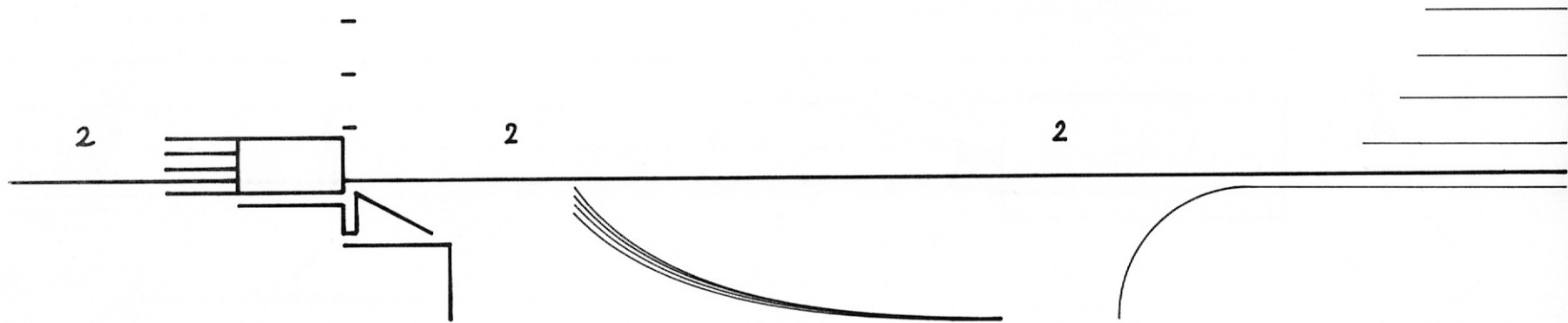

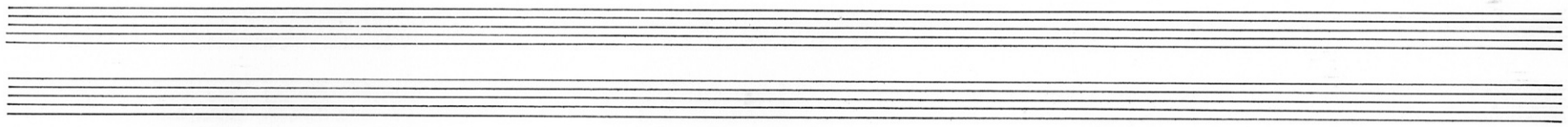
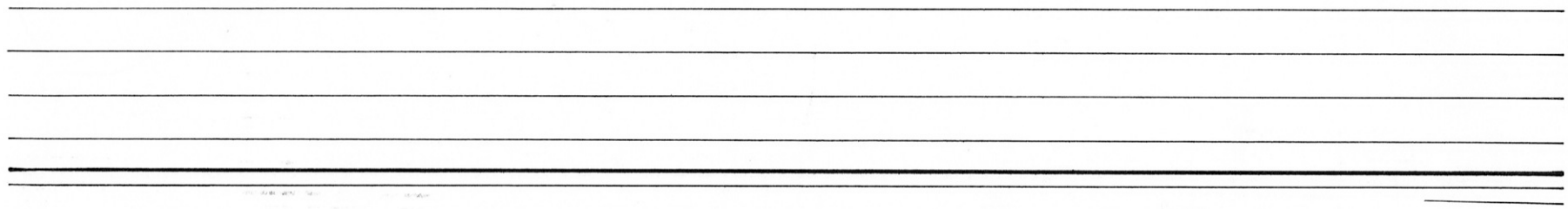

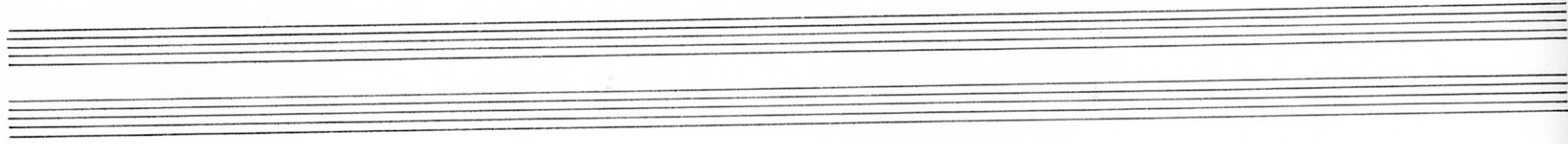
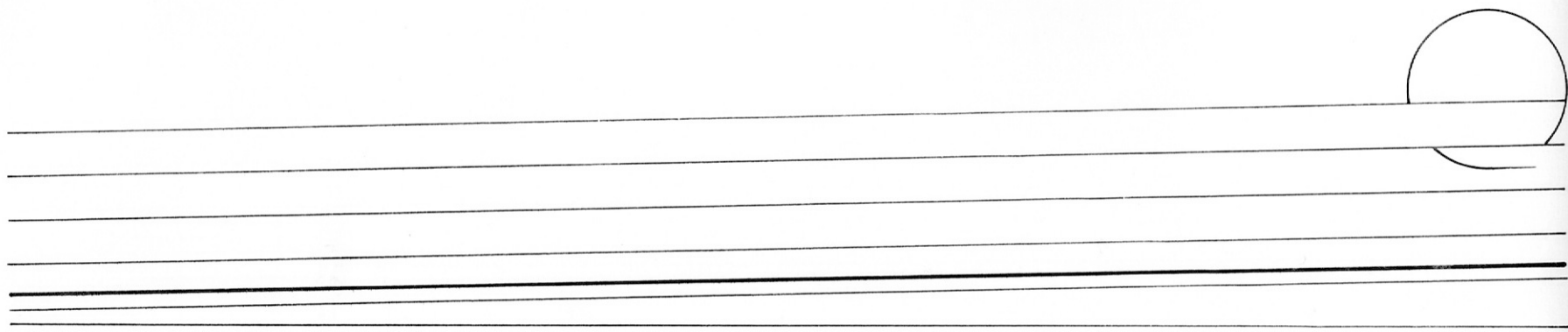

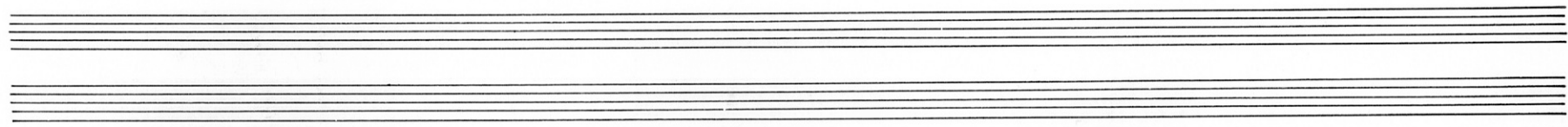
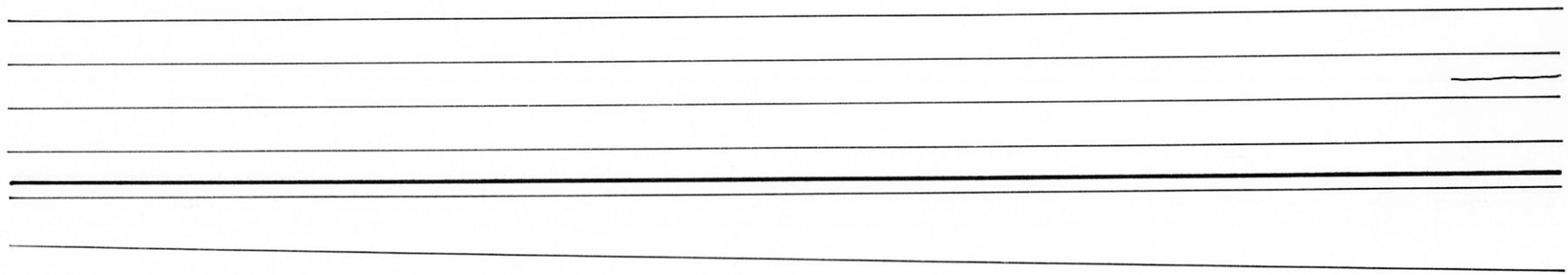

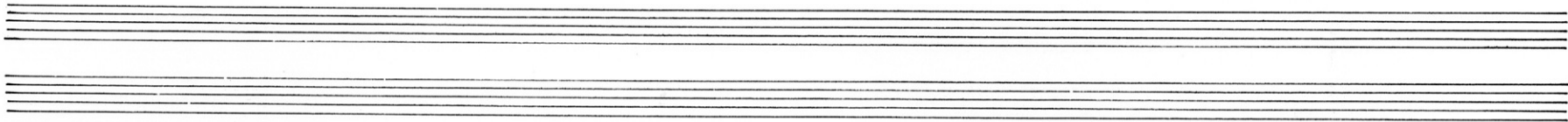
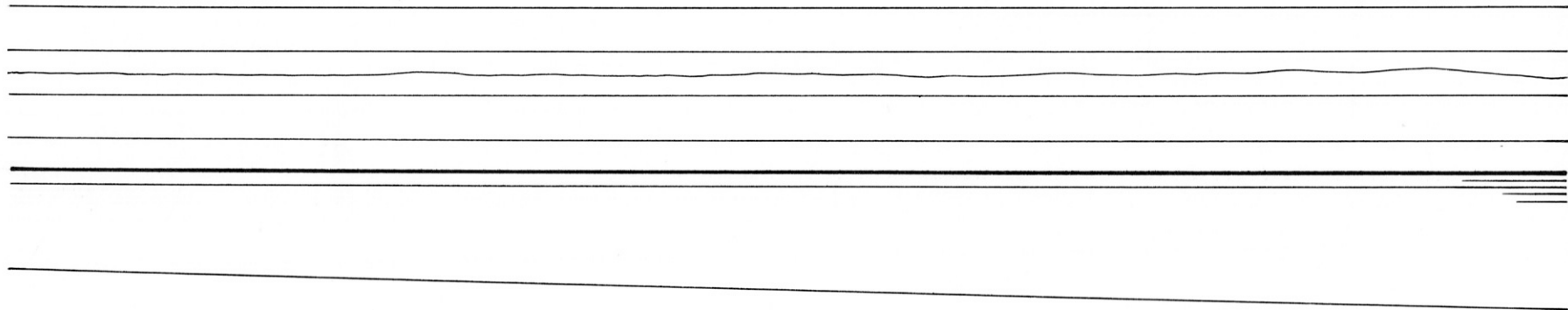

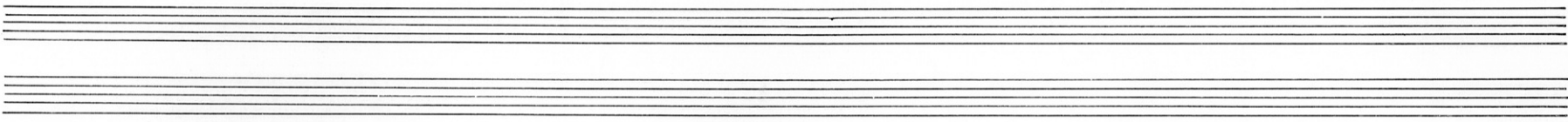
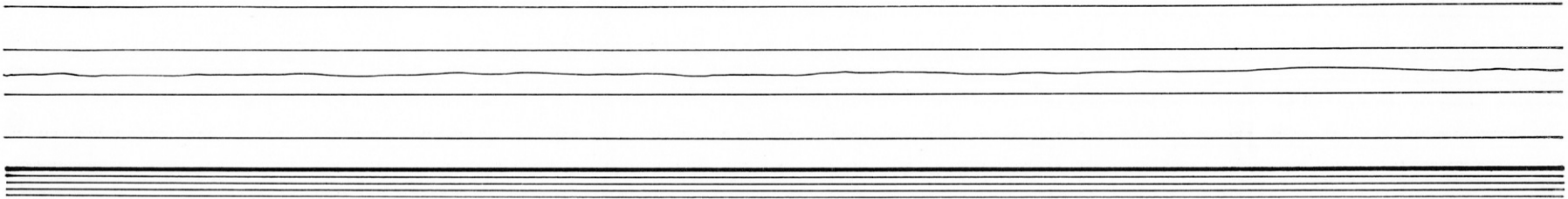

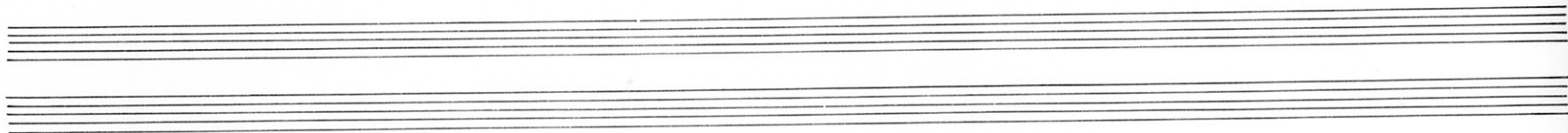
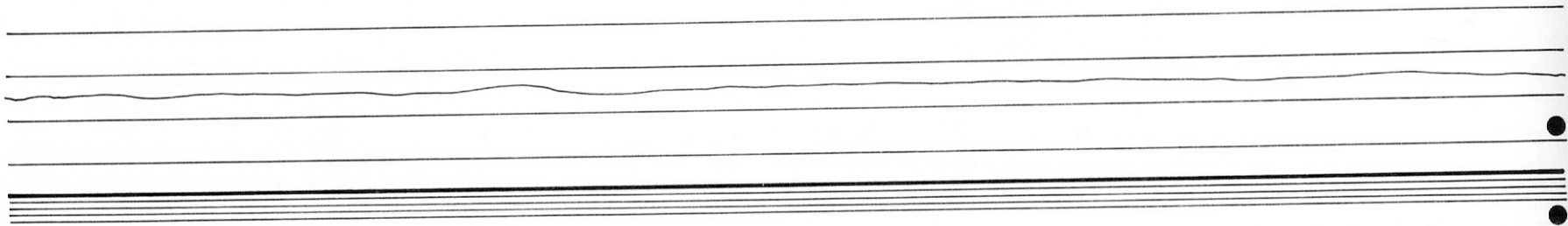

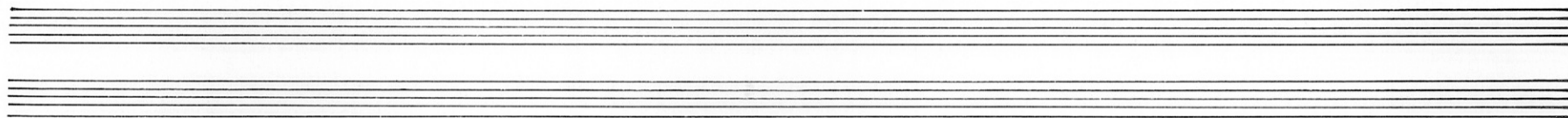
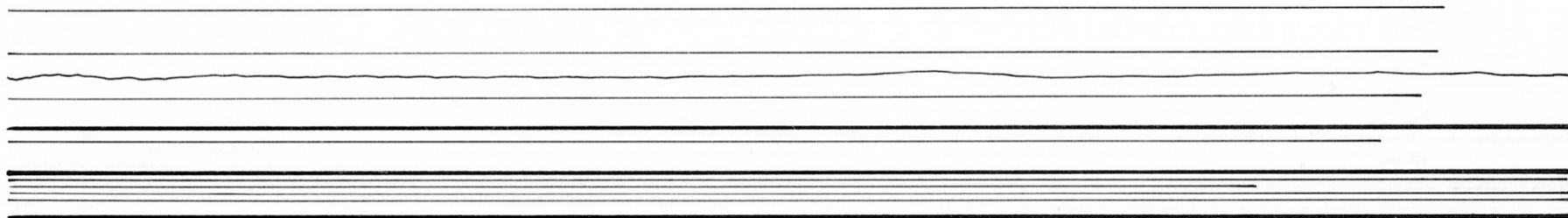

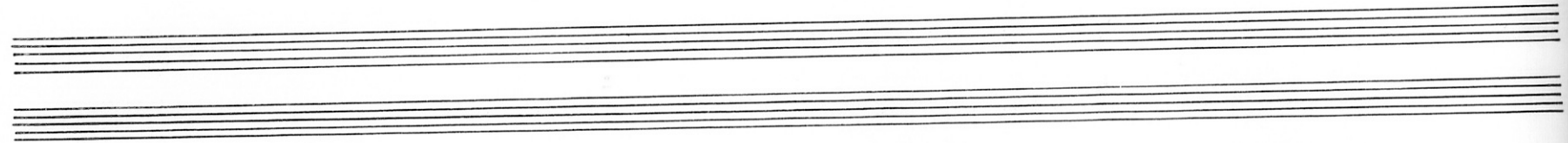
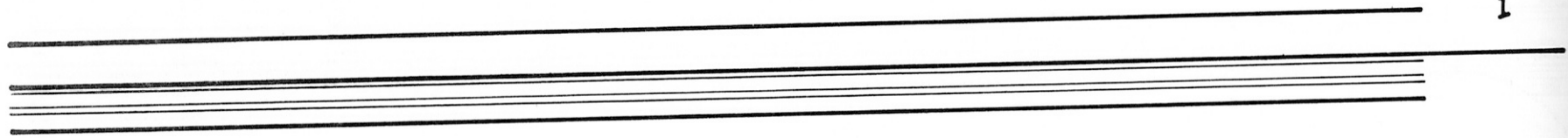

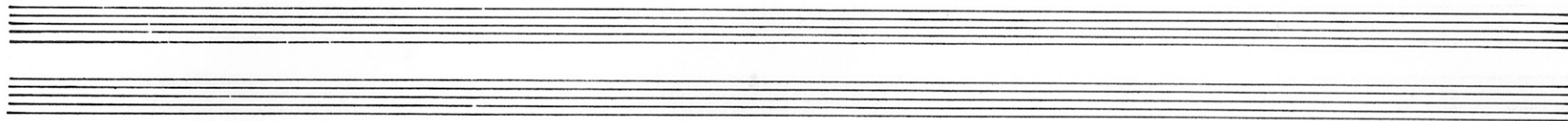
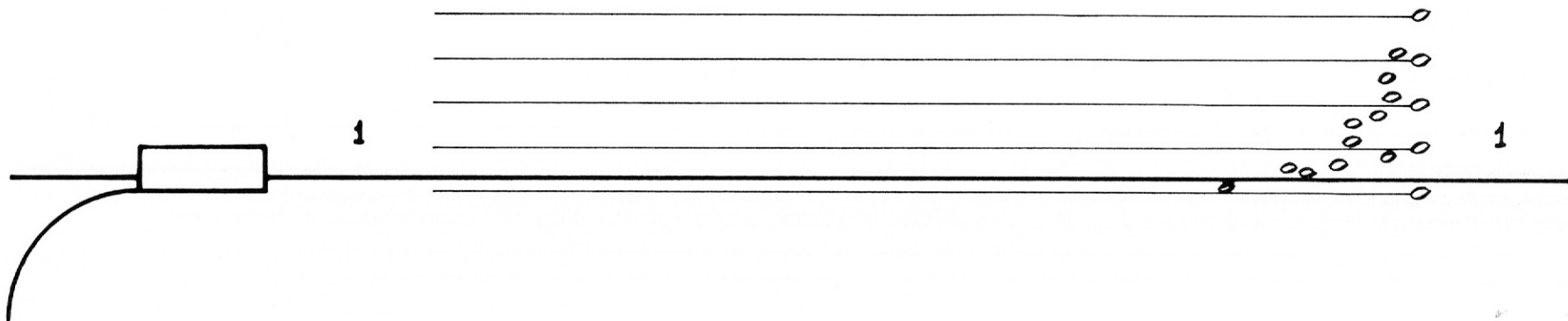

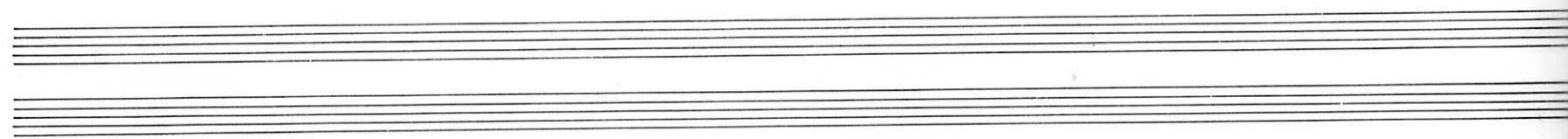
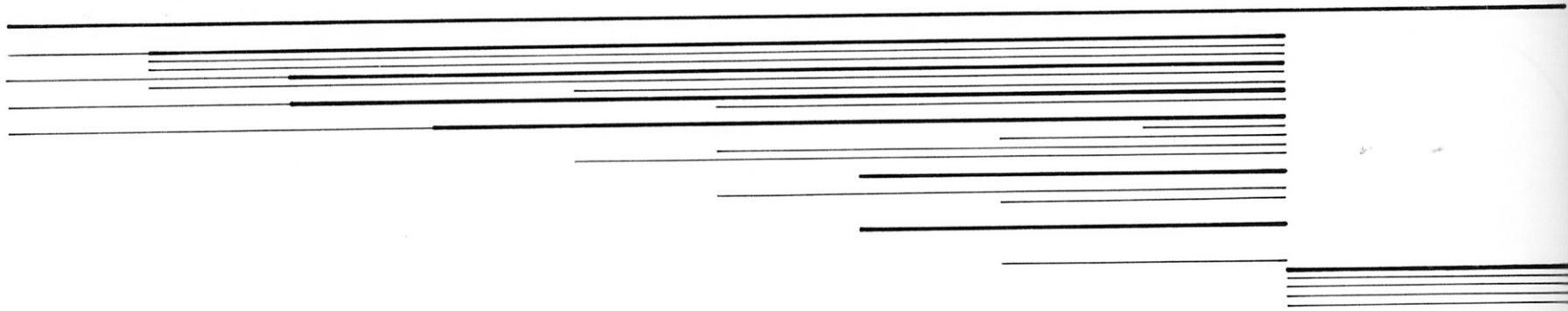

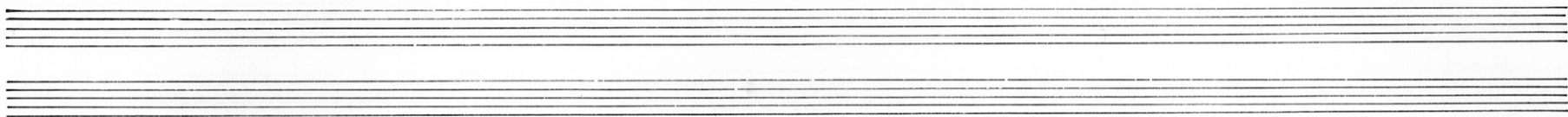
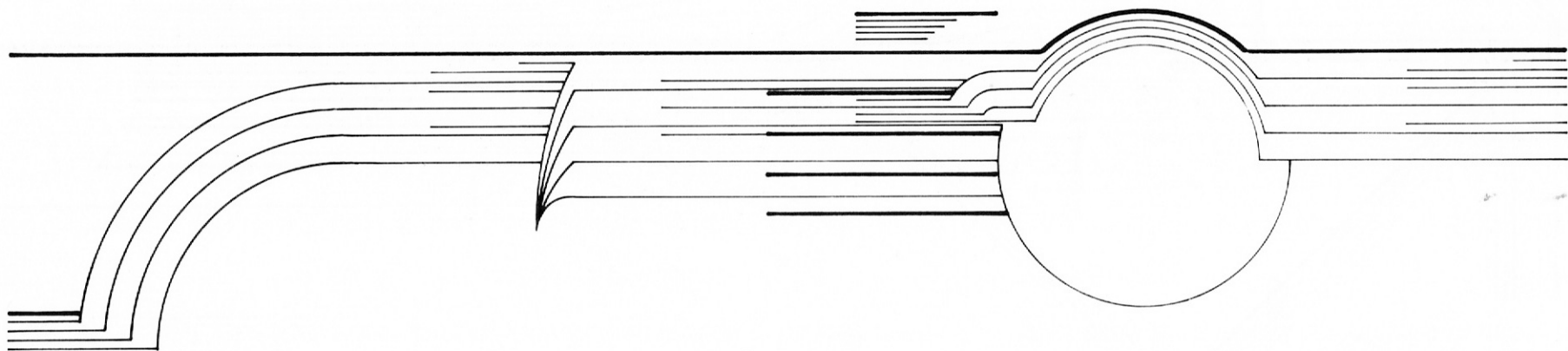

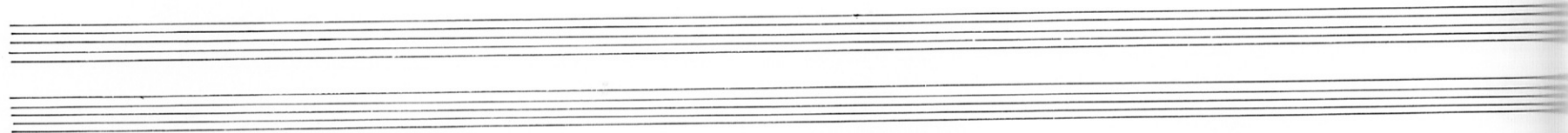
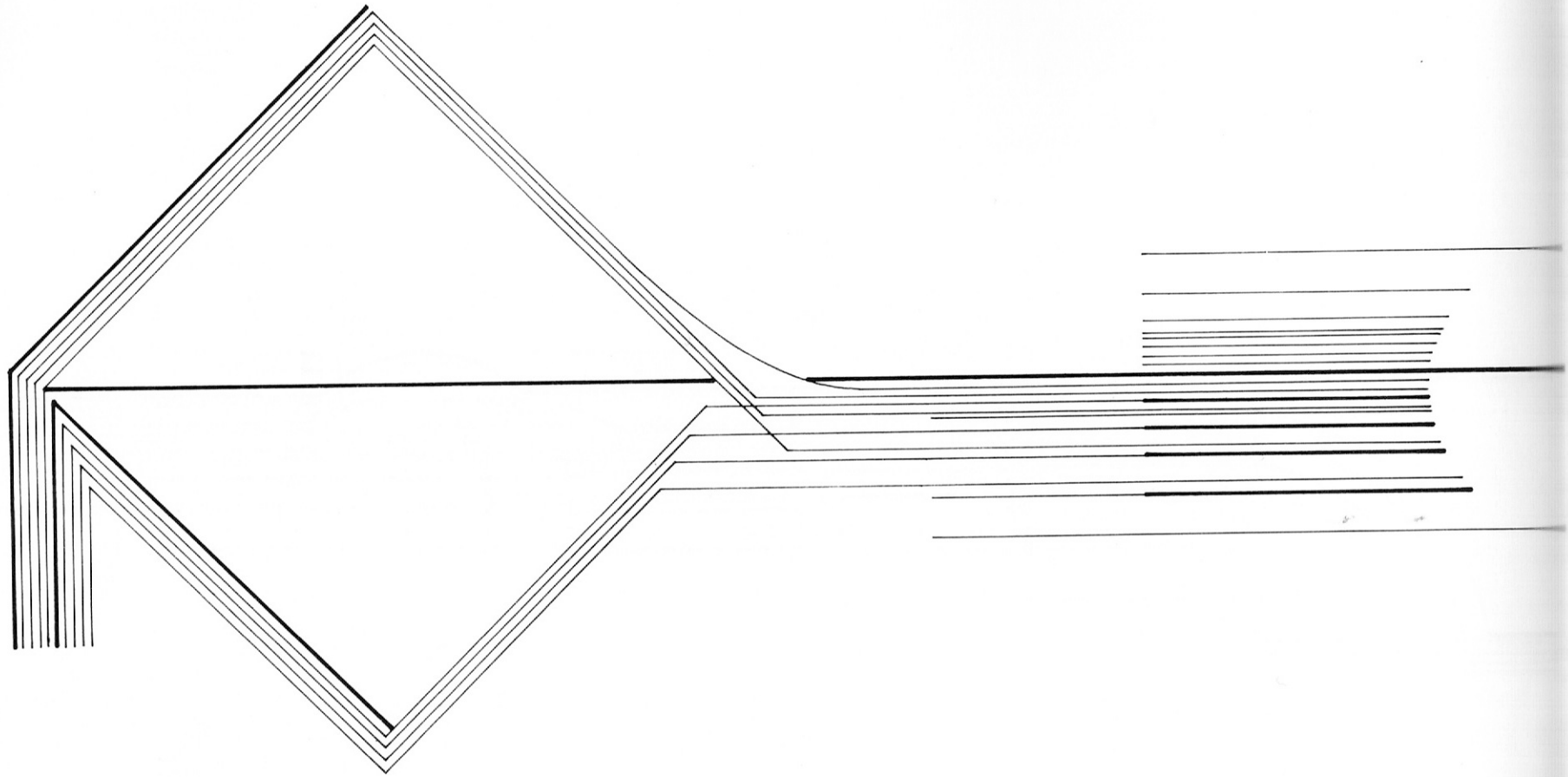

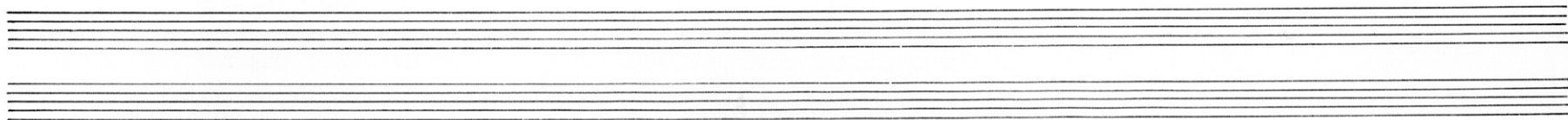
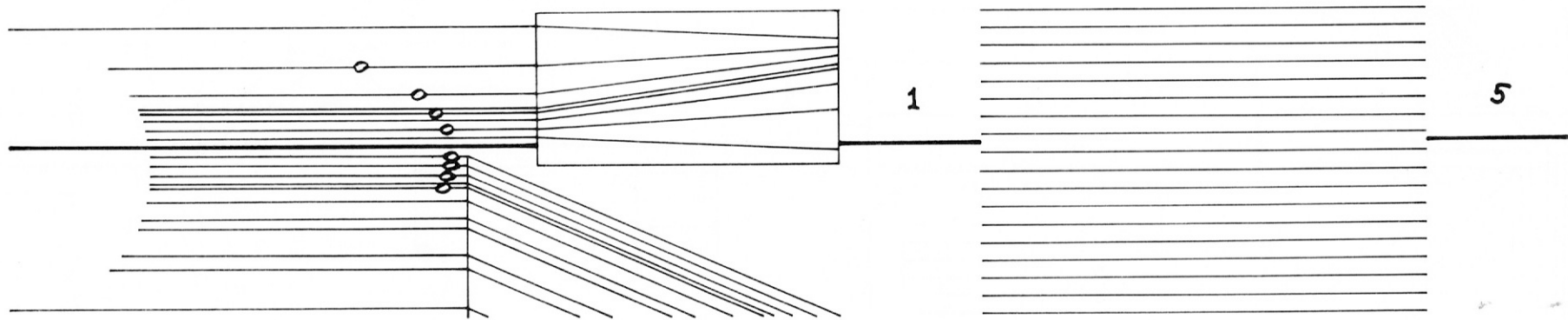

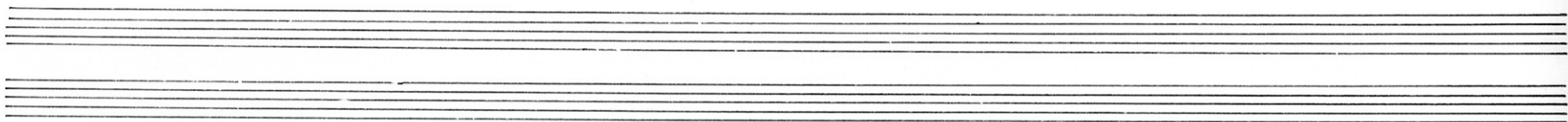
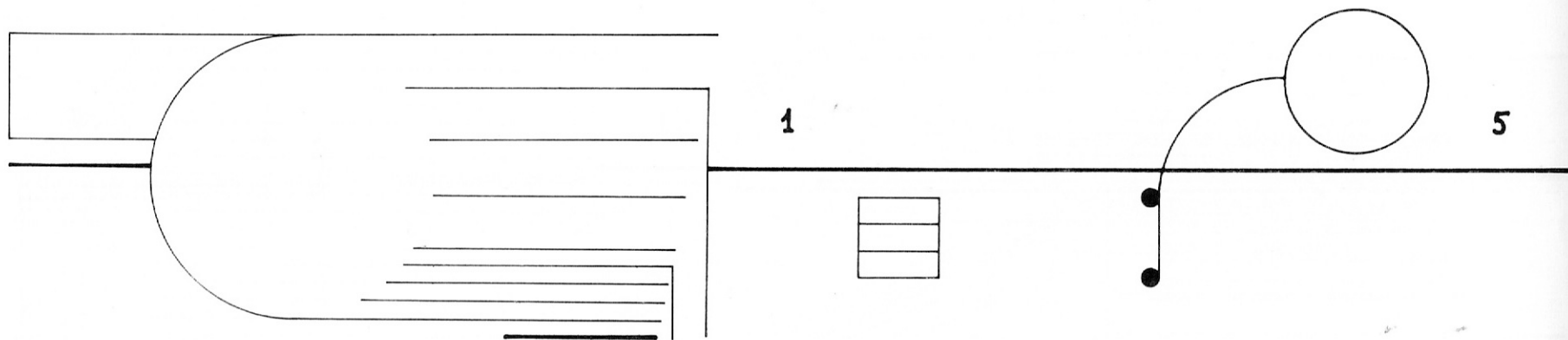

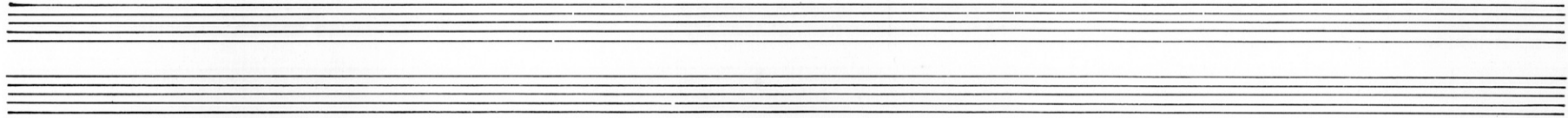
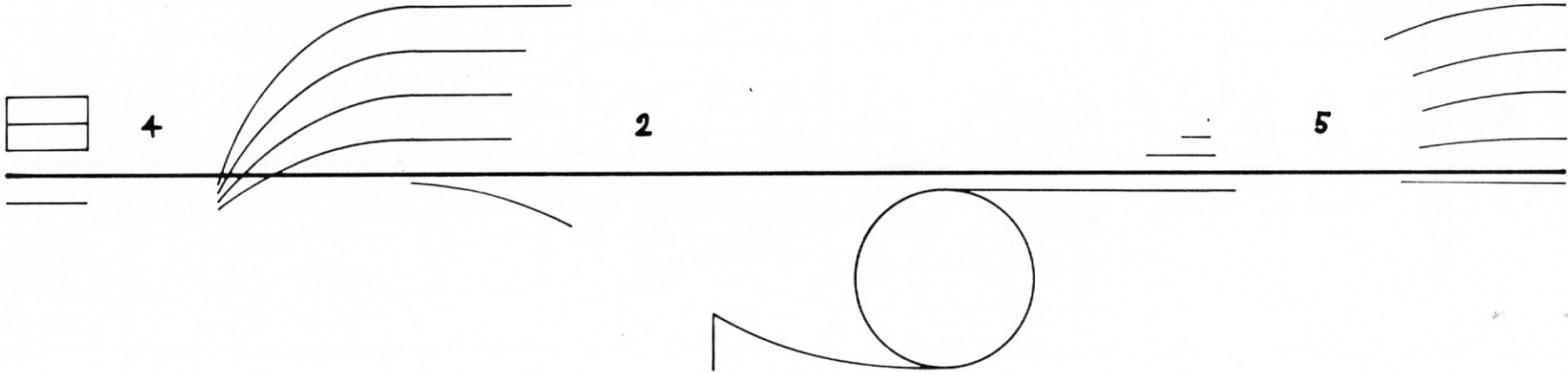

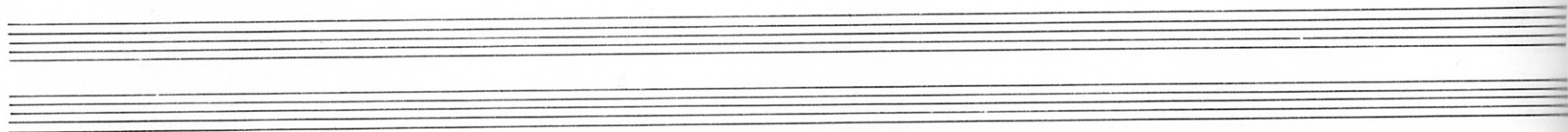
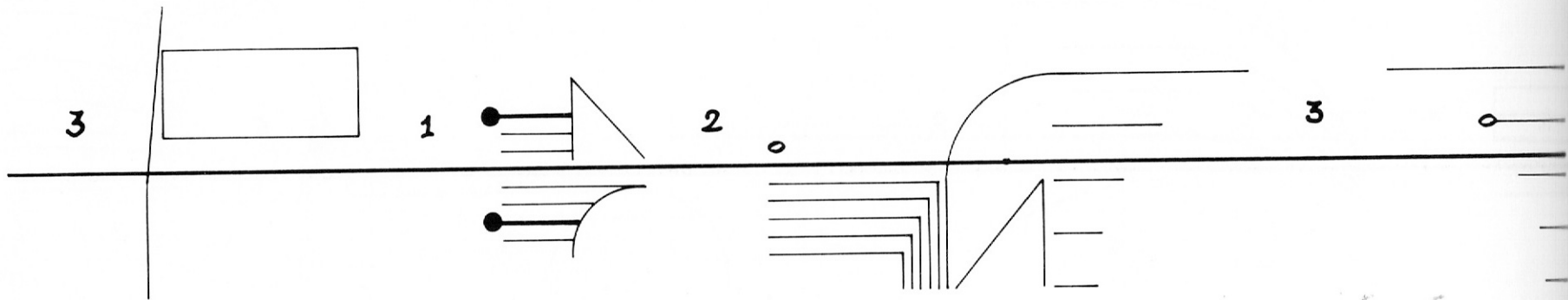

1

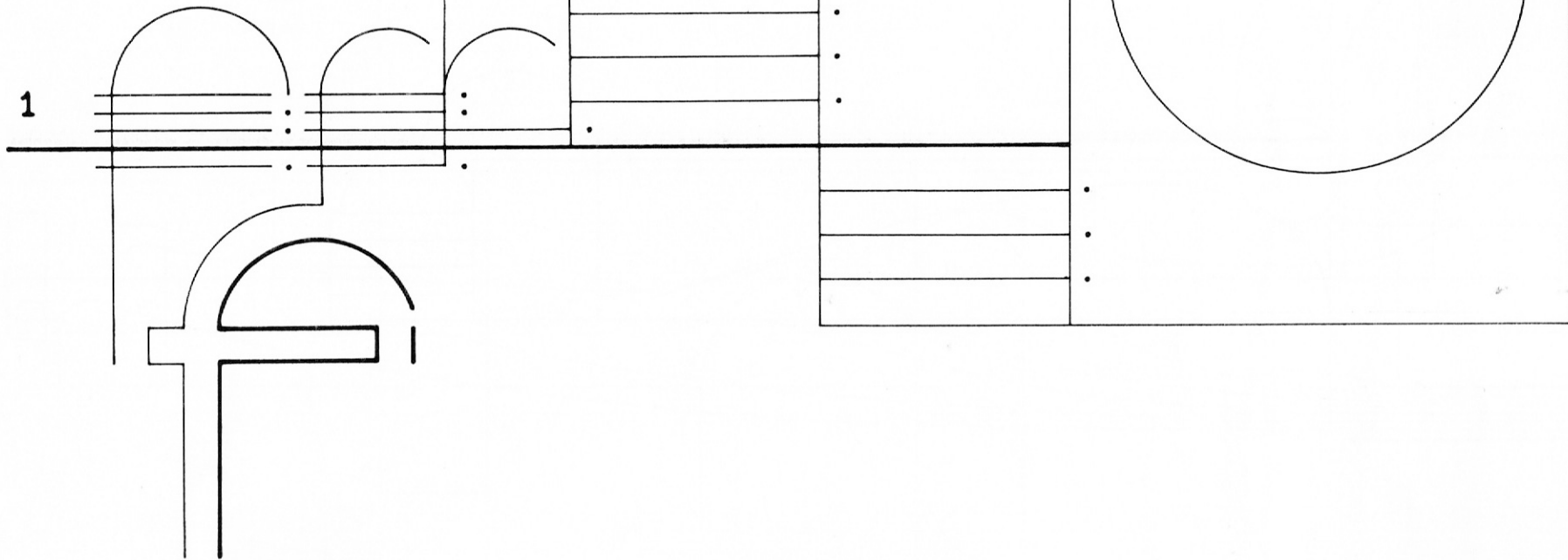

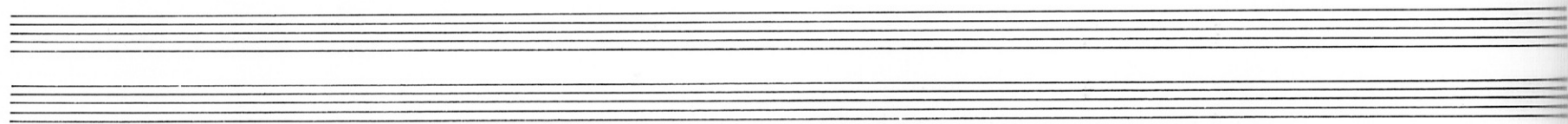
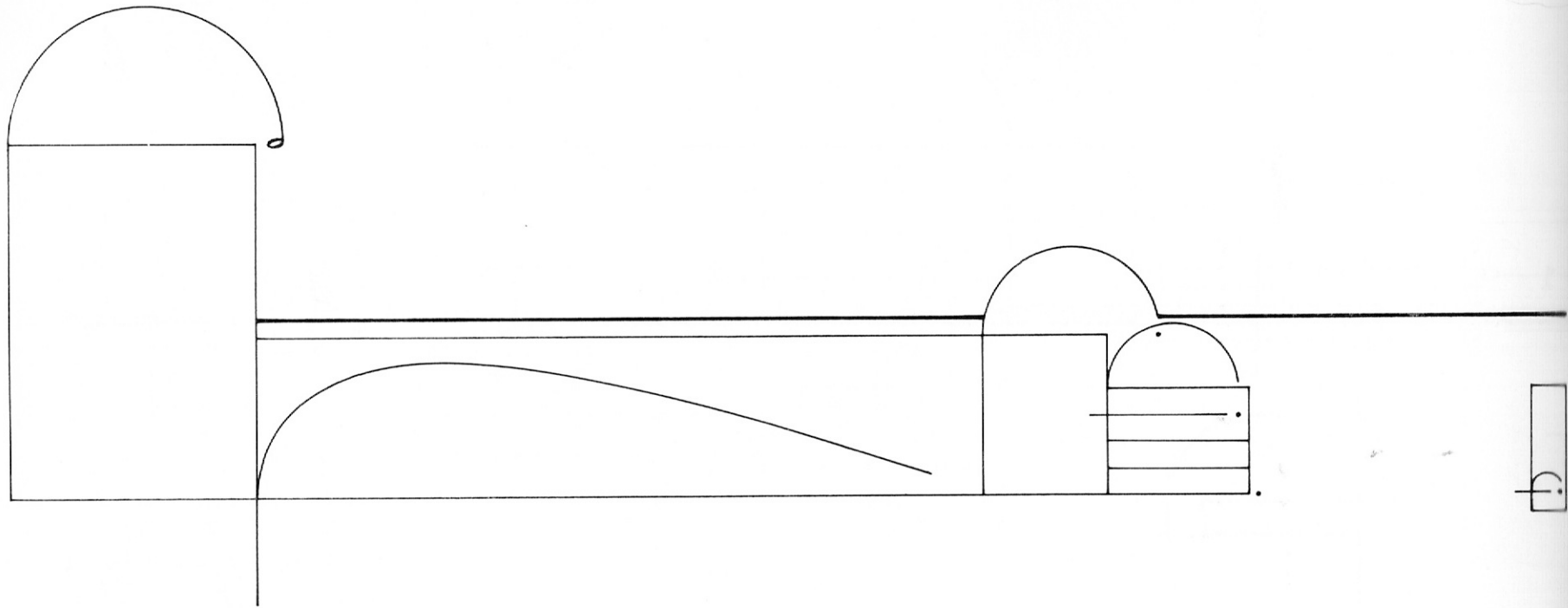

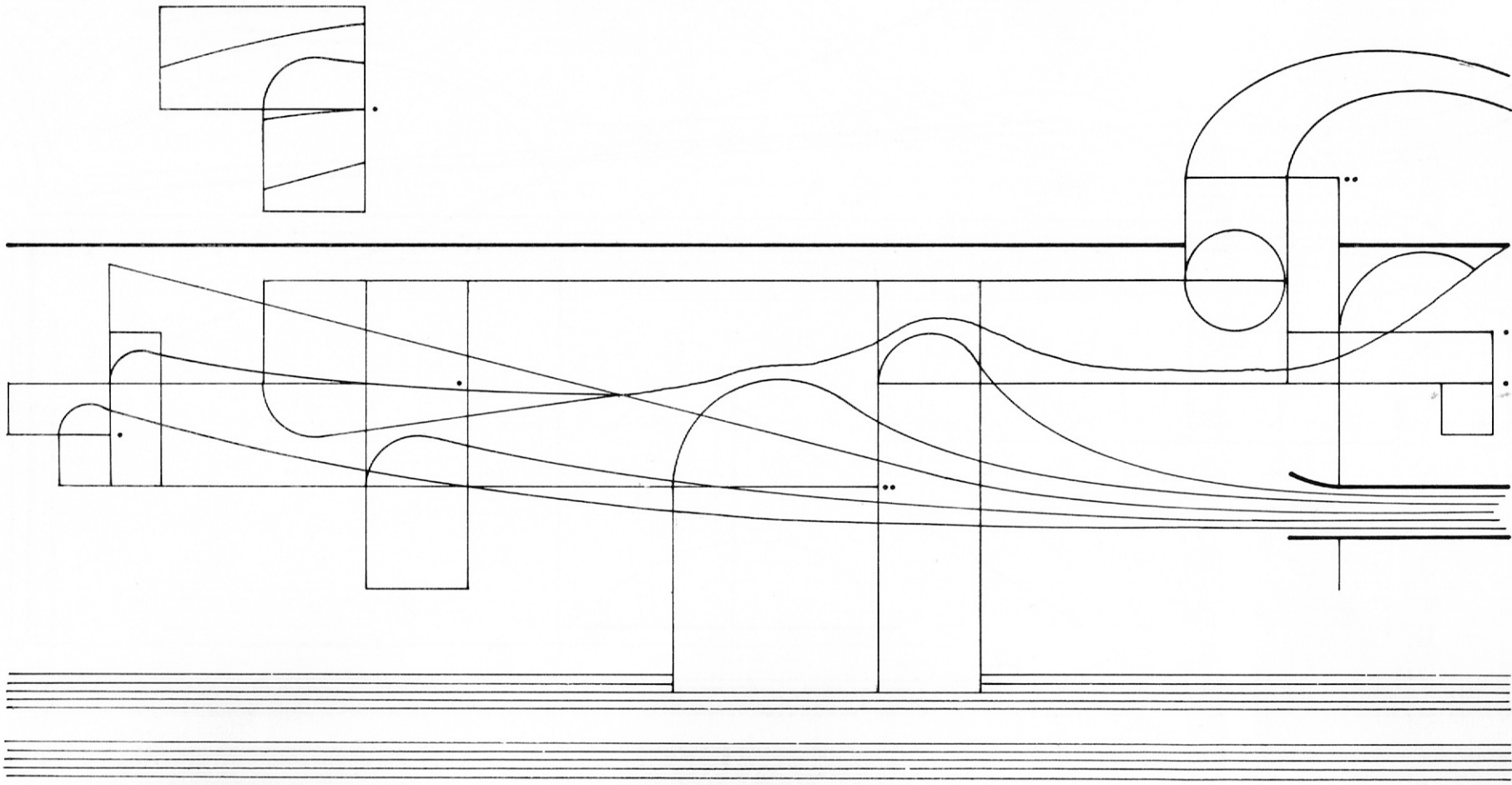

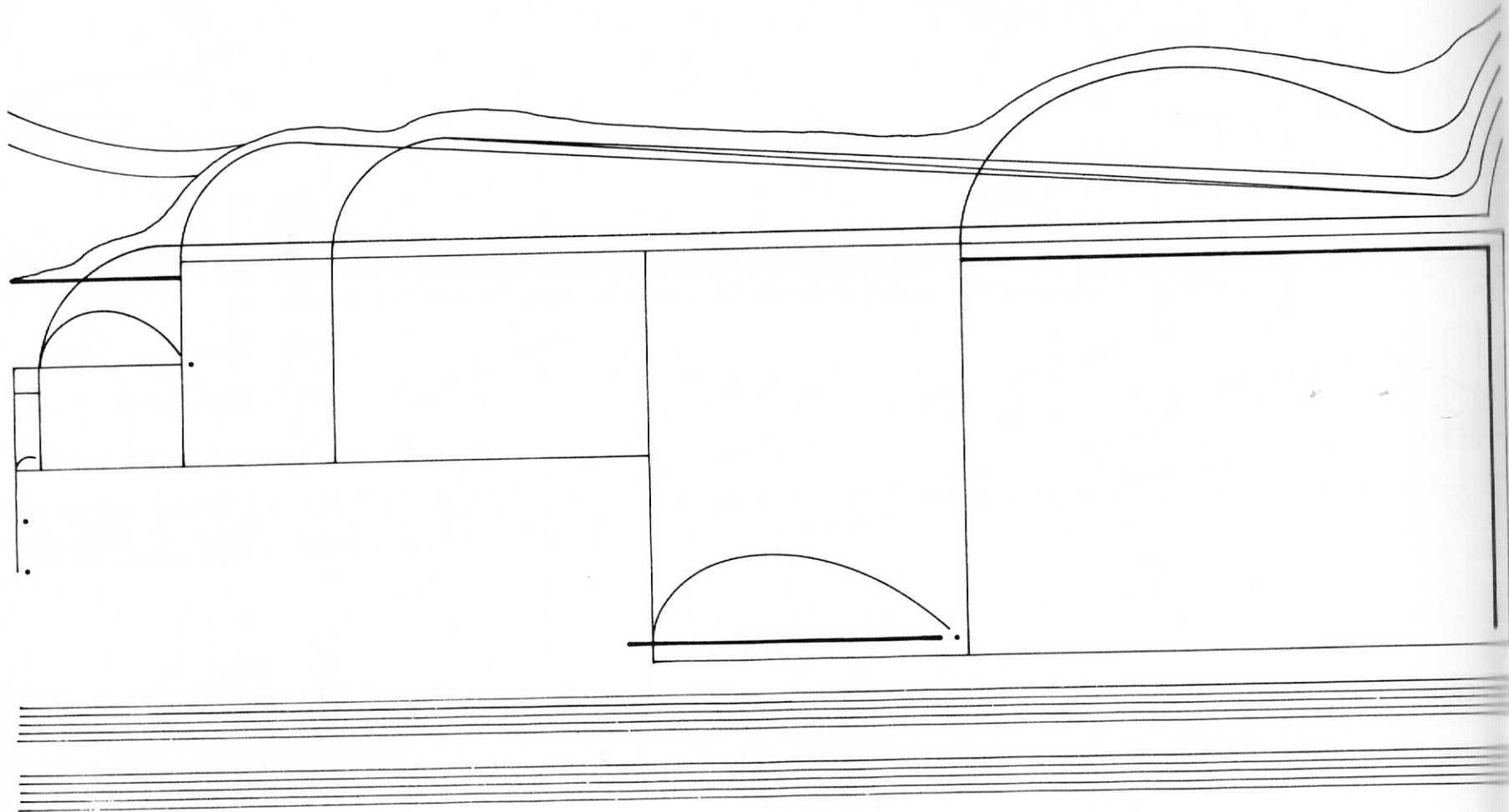

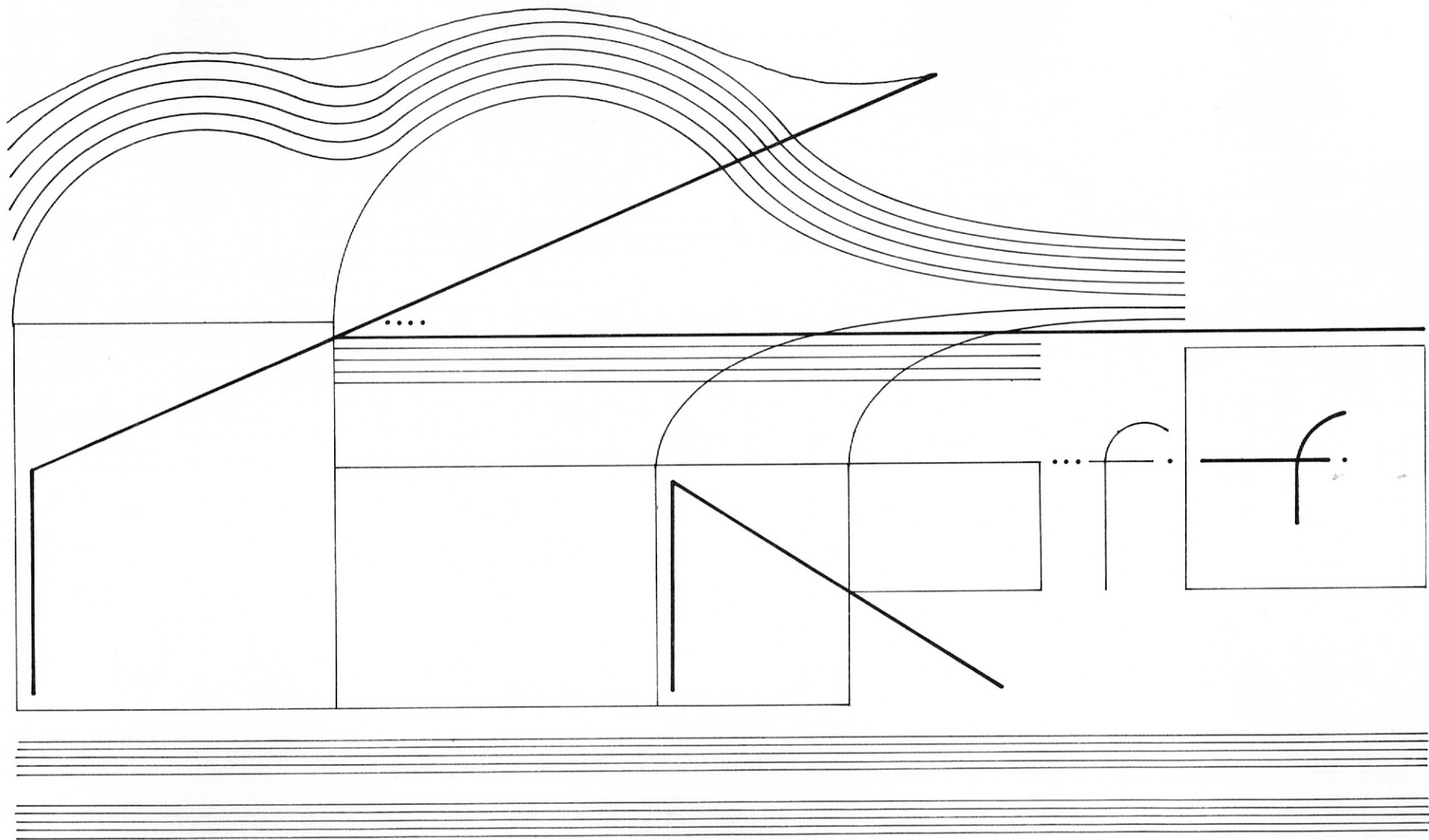

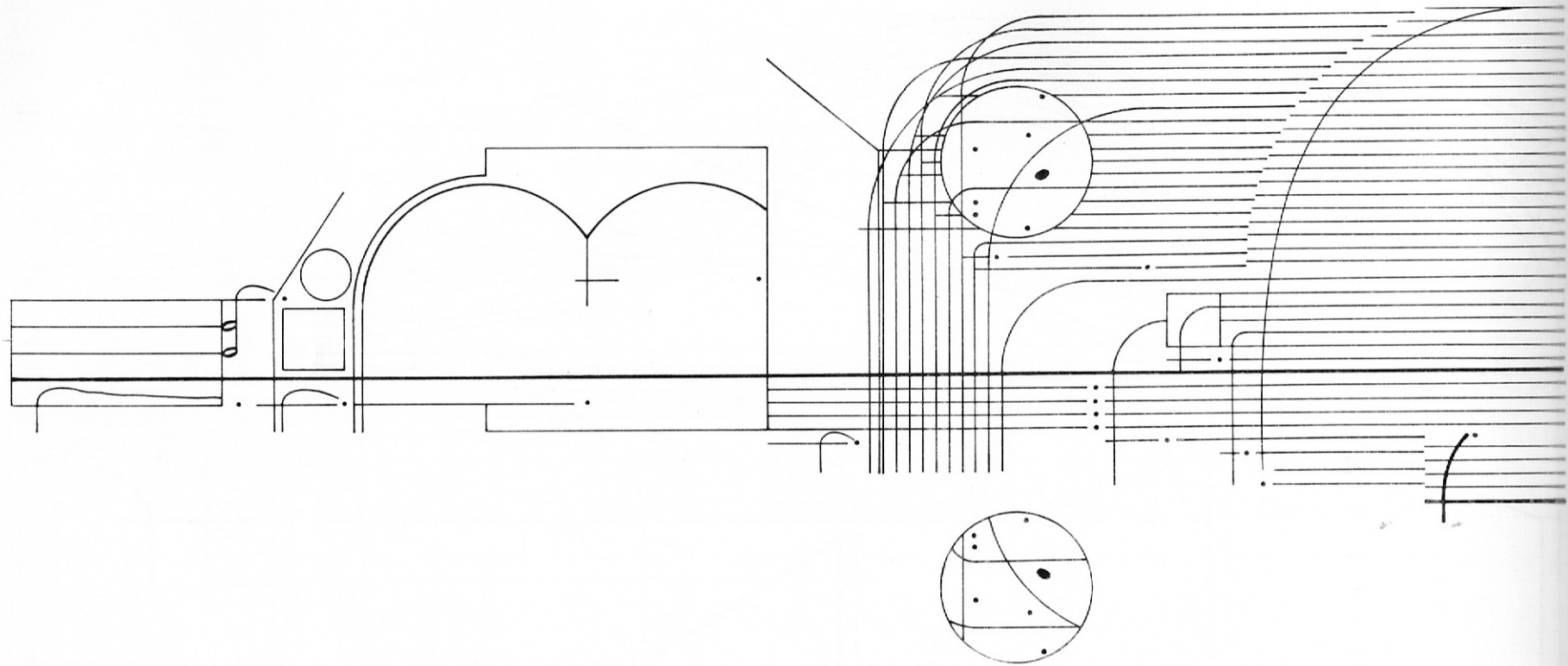

This image shows a handwritten musical score on a page with a grid of 12 staves. The notation is highly complex and abstract, featuring several diamond-shaped diagrams on the left side. The top two staves contain a diamond diagram with a cross inside, and the bottom two staves contain another similar diamond diagram. The central part of the score is filled with dense, overlapping lines and notes, including treble and bass clefs, and various musical symbols. The right side of the page shows a continuation of the notation with a few more notes and a diamond diagram. The overall appearance is that of a highly experimental or avant-garde musical composition.

A set of empty musical staves, consisting of two systems of five lines each, located at the bottom of the page.

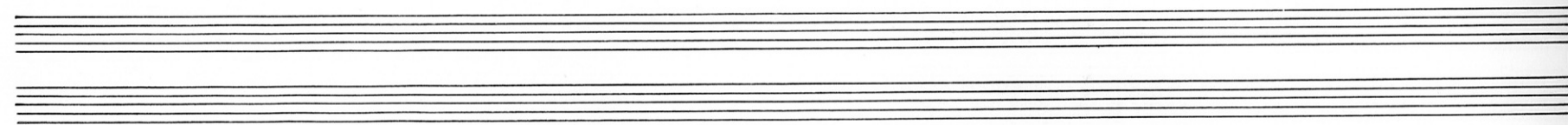
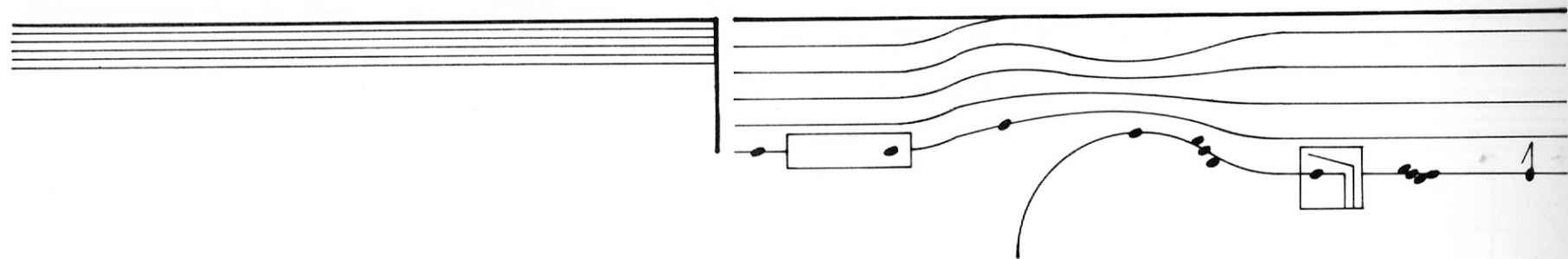
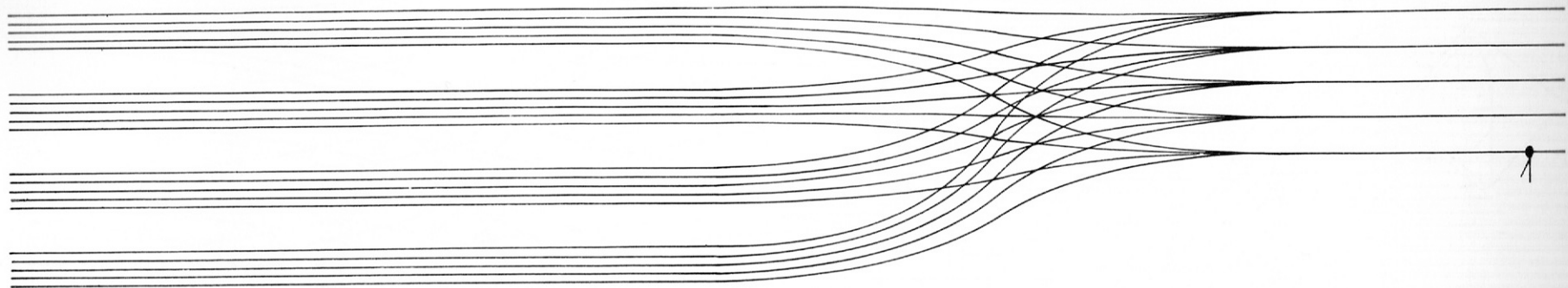

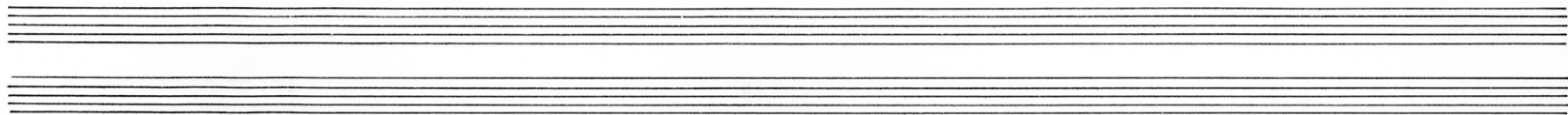
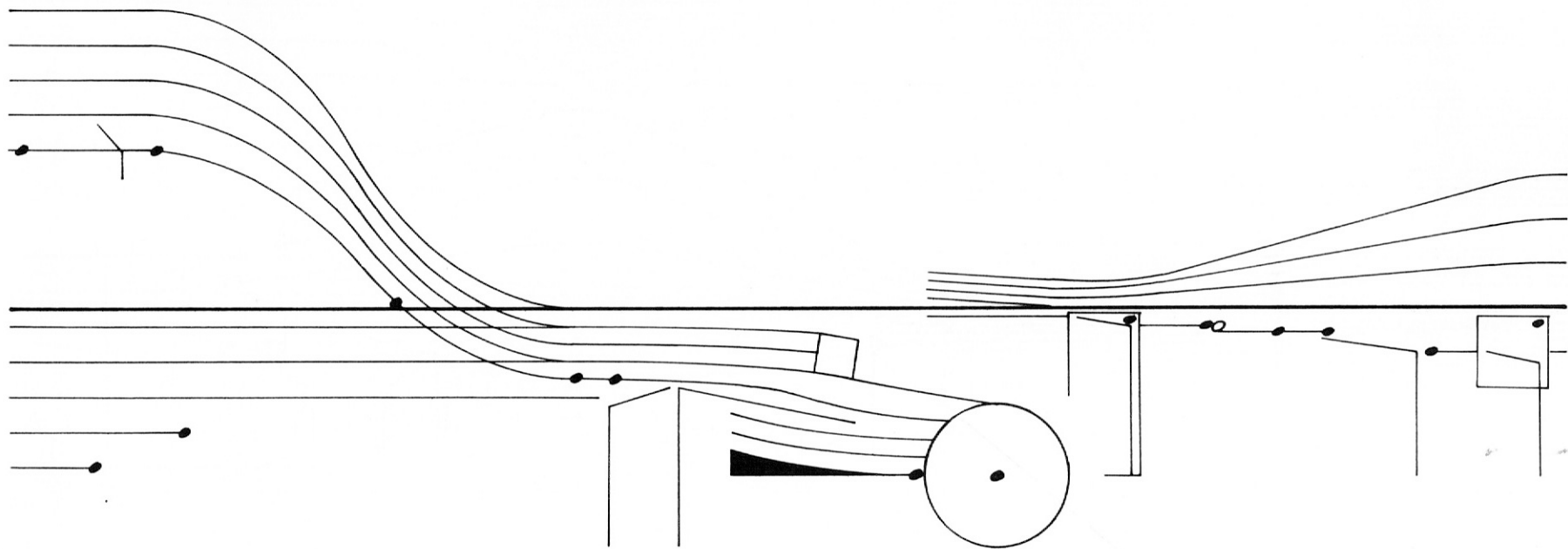

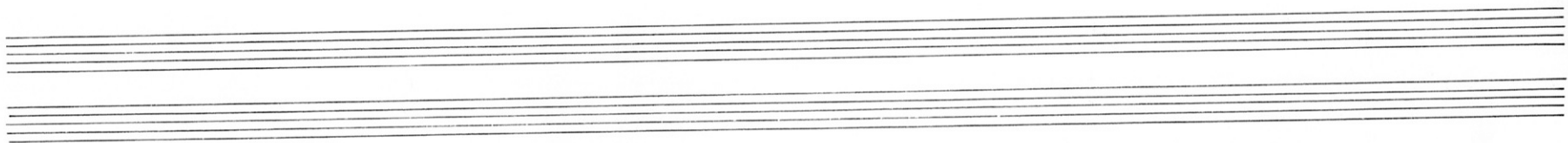
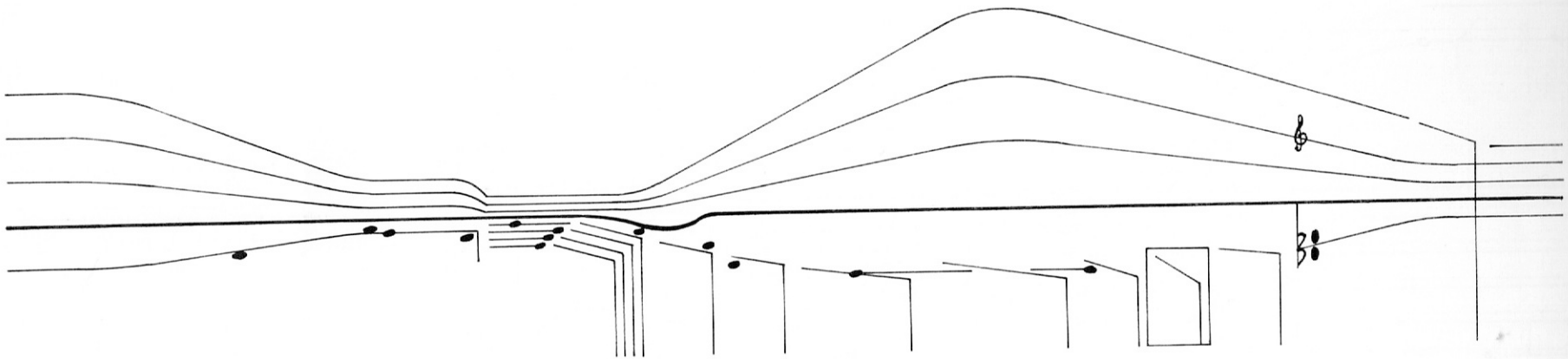

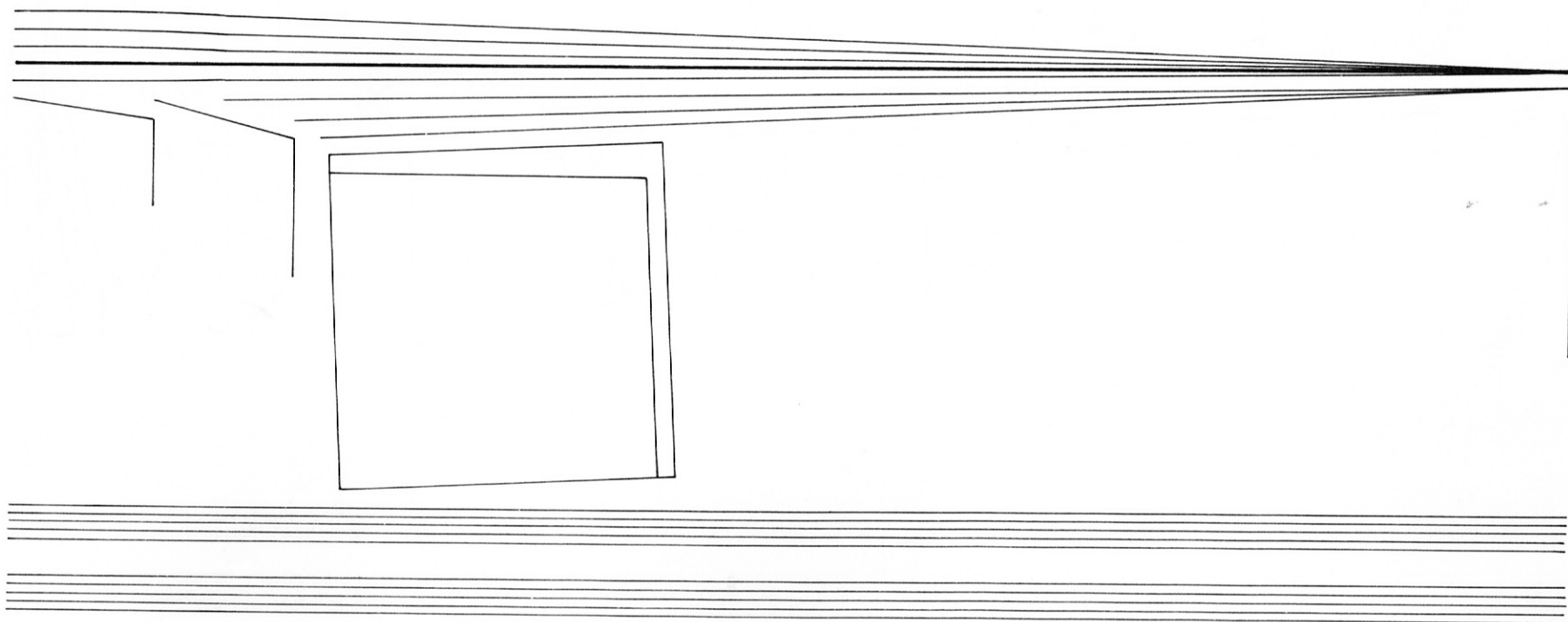

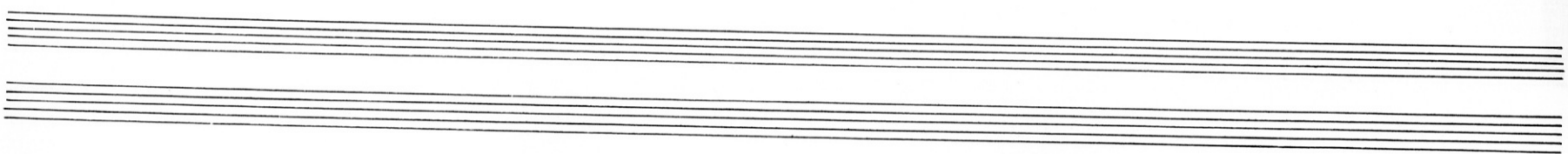
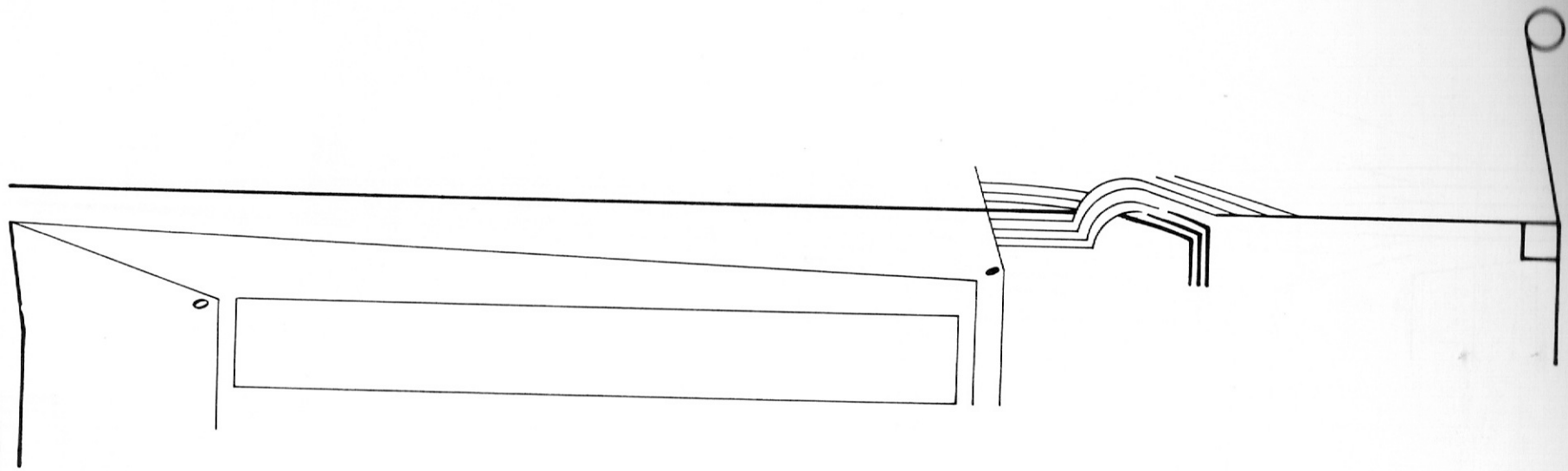

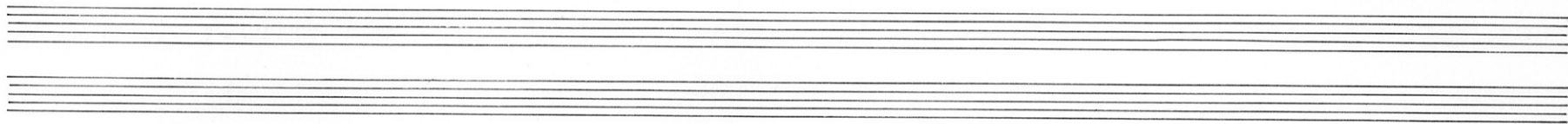
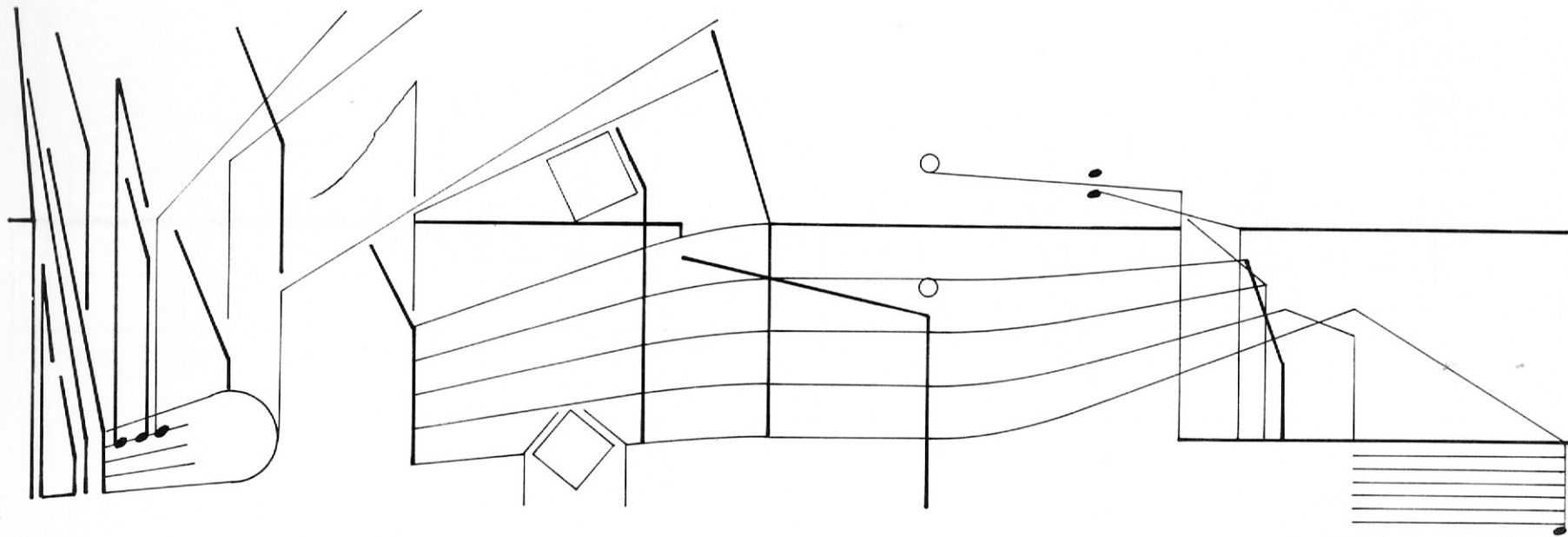

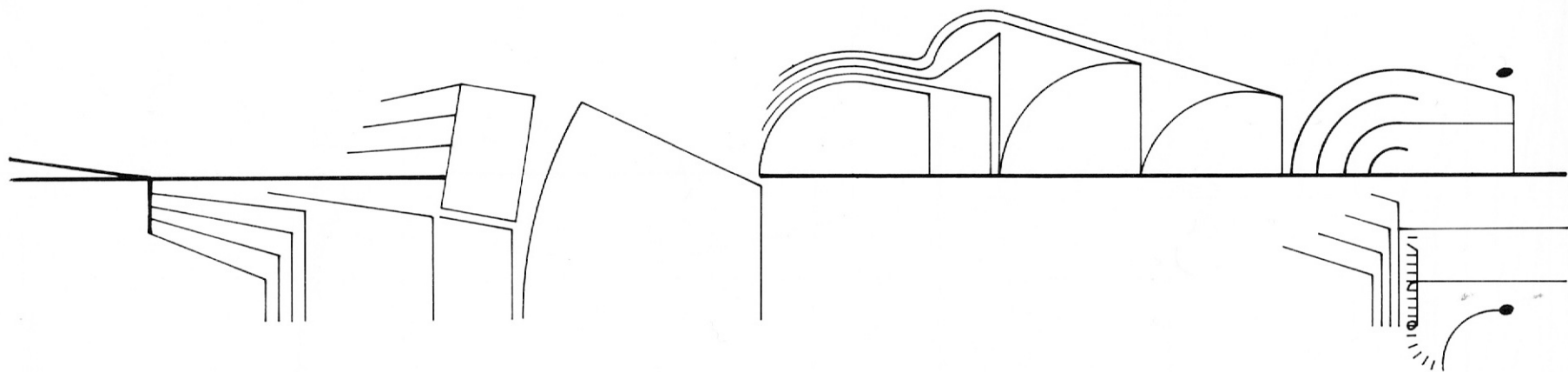

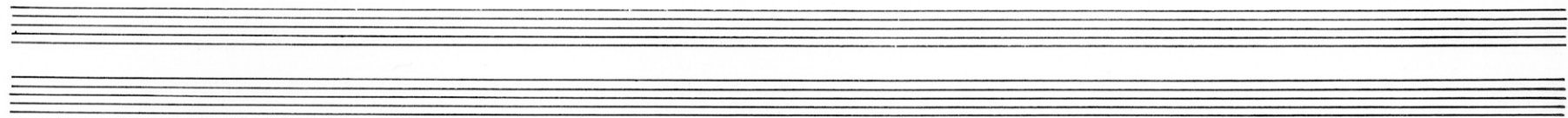
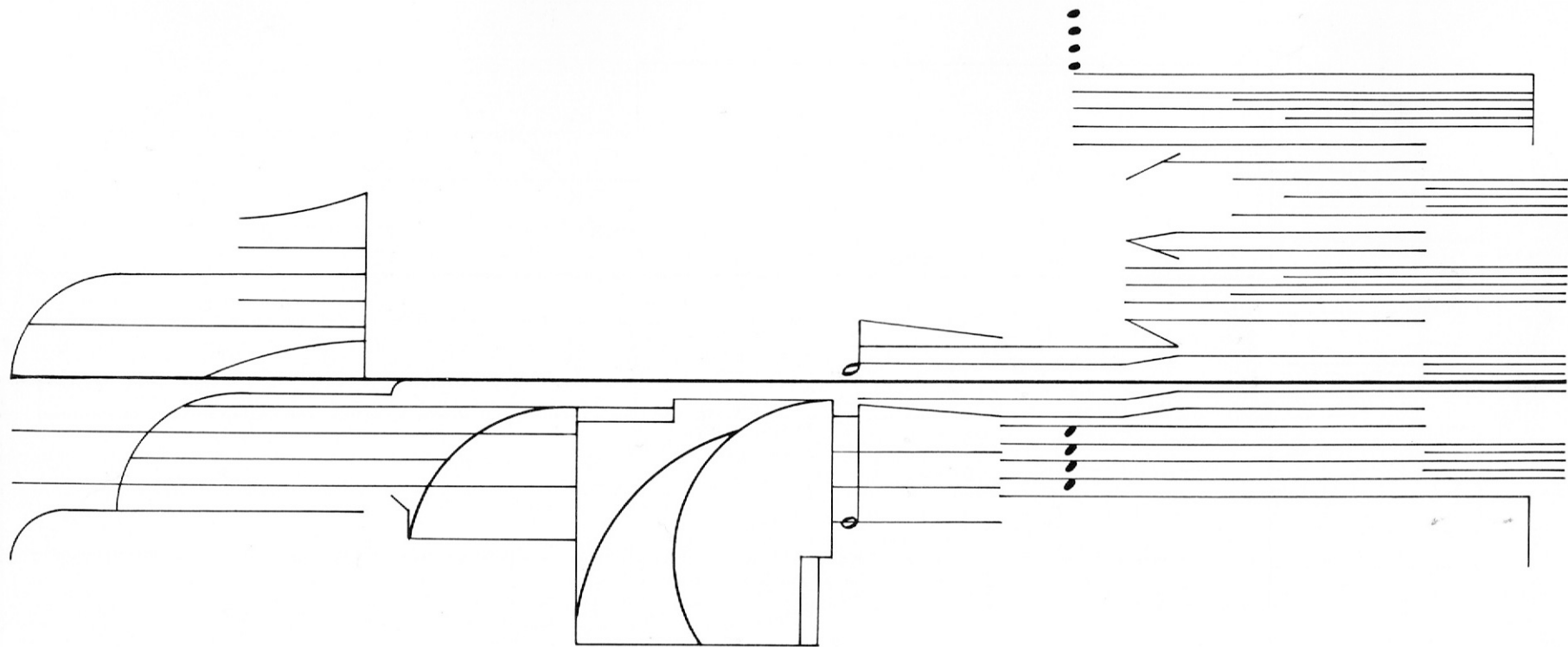

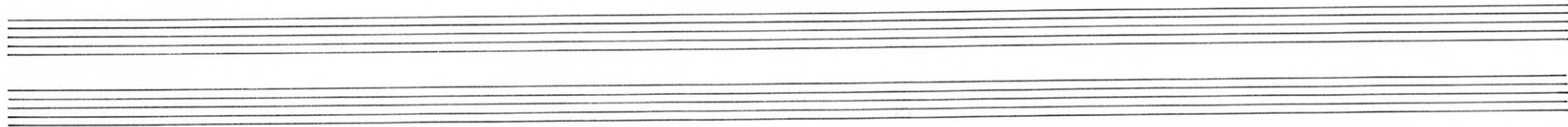
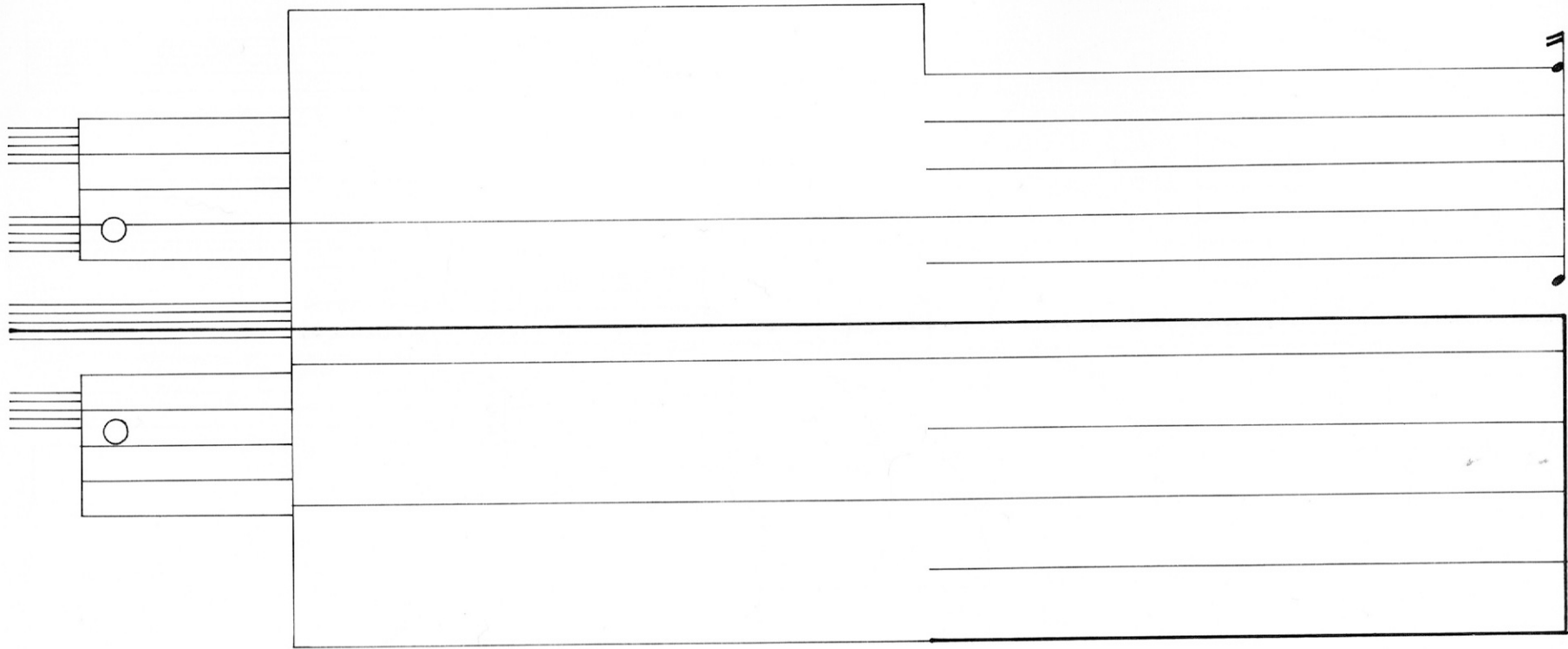

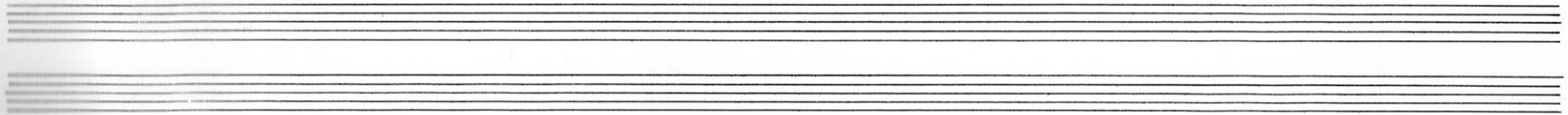
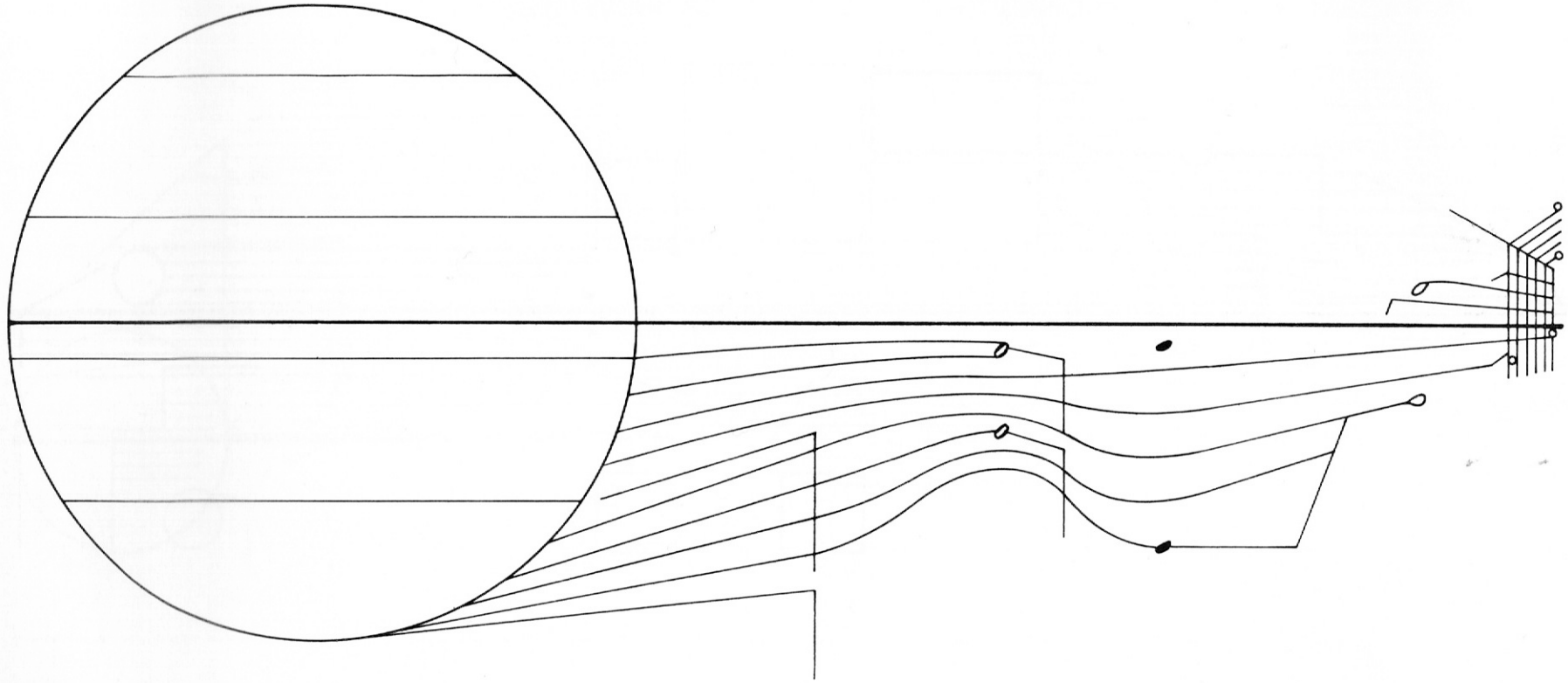

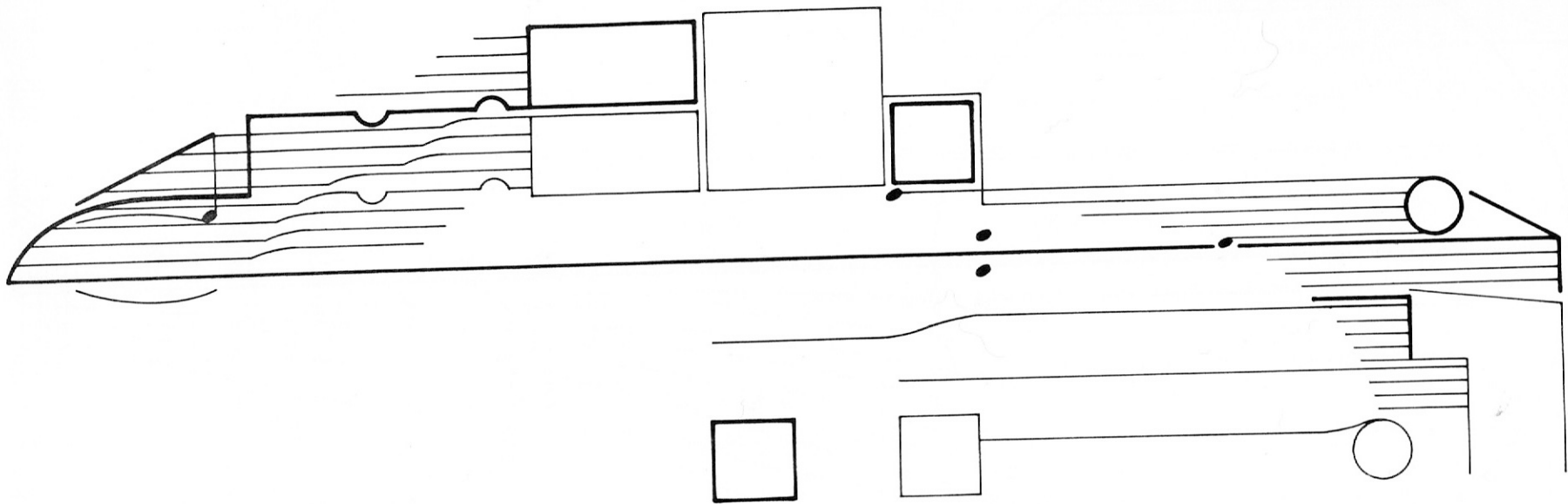

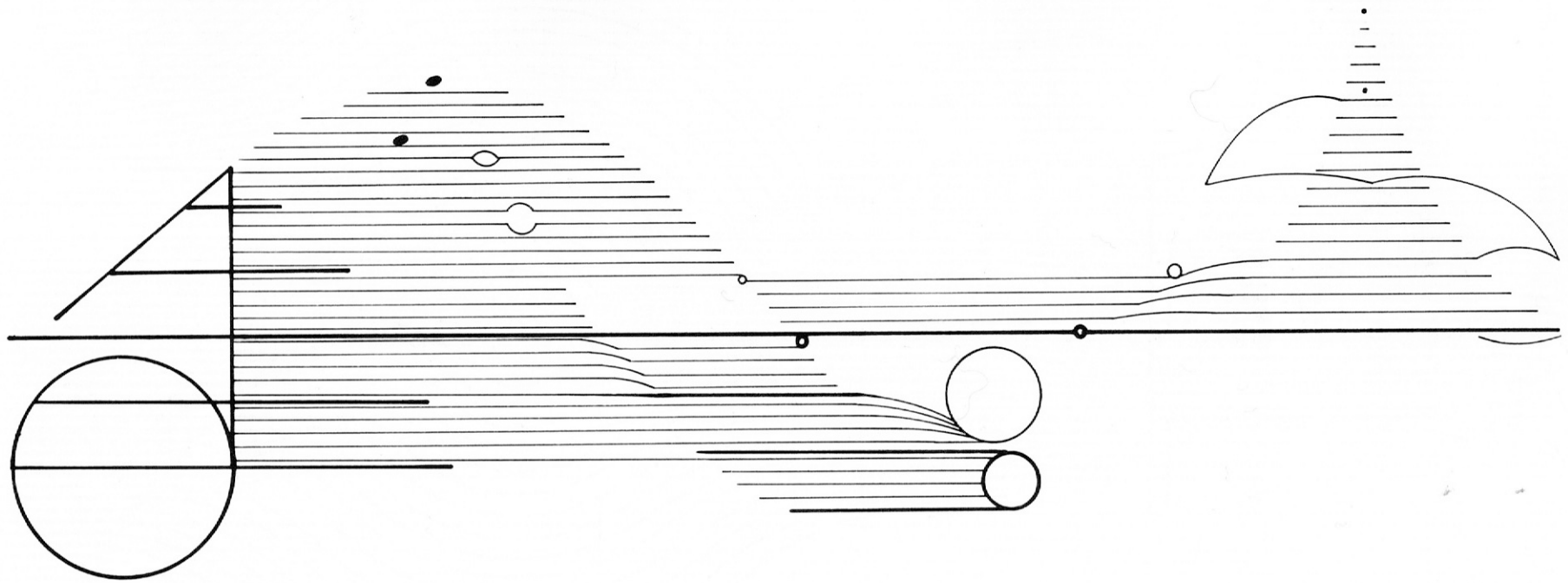

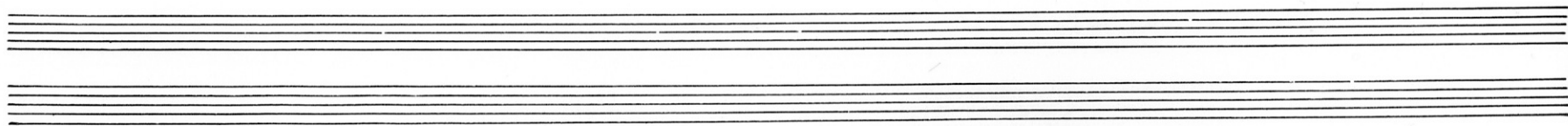
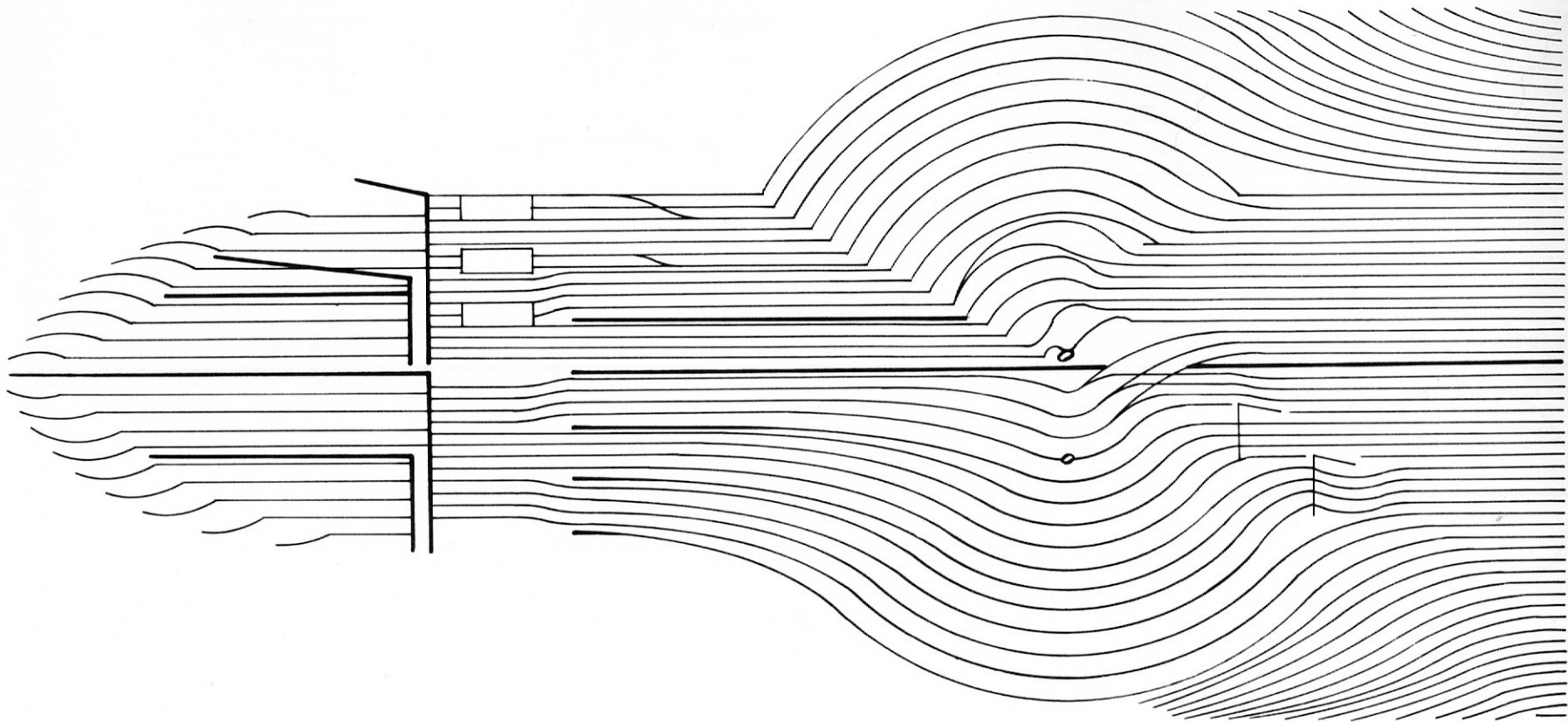

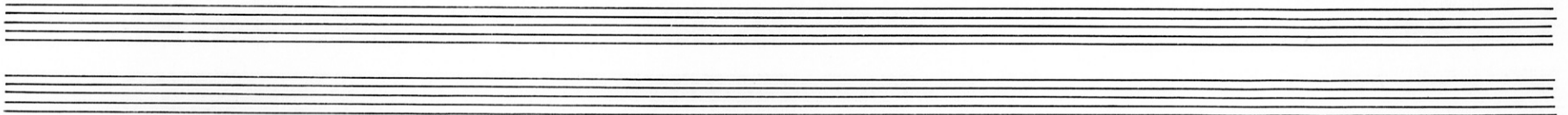
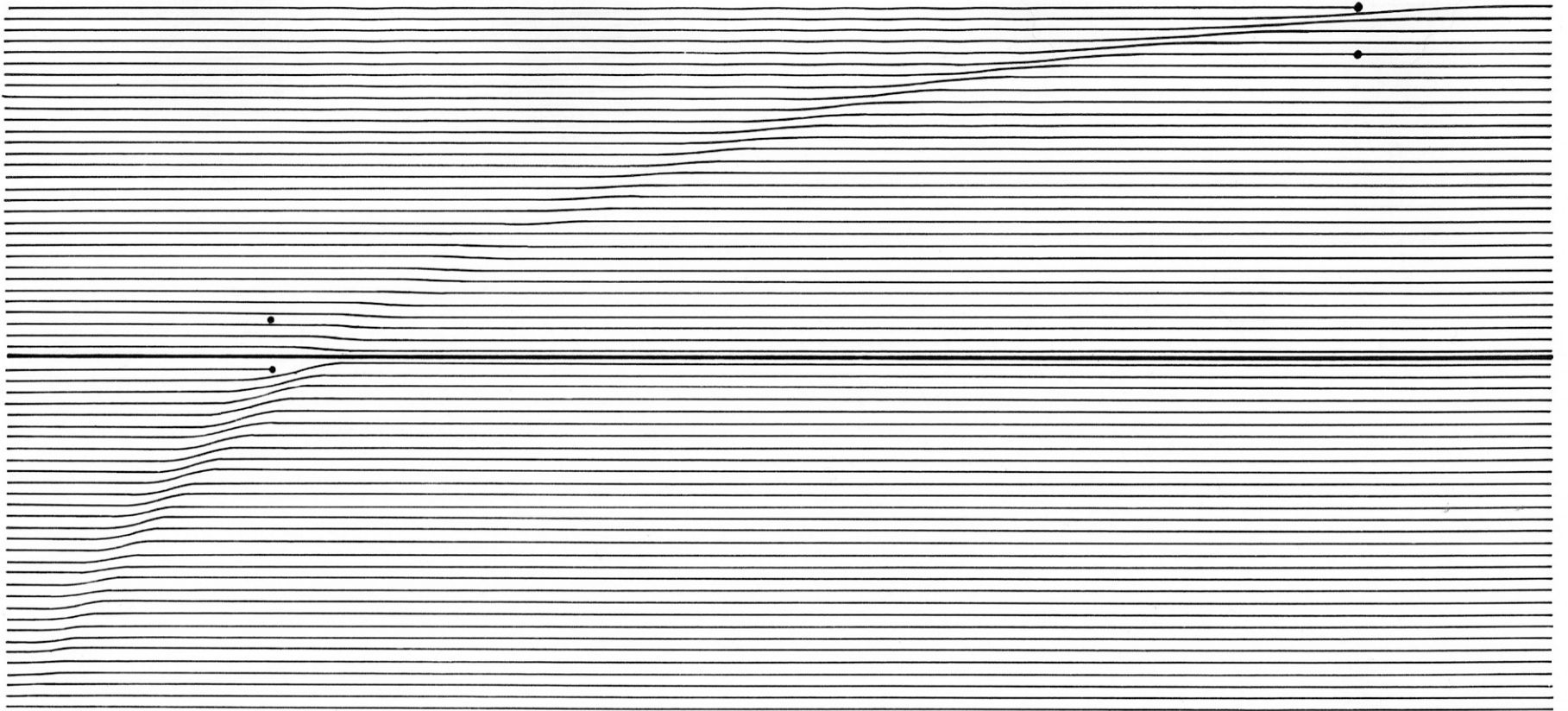

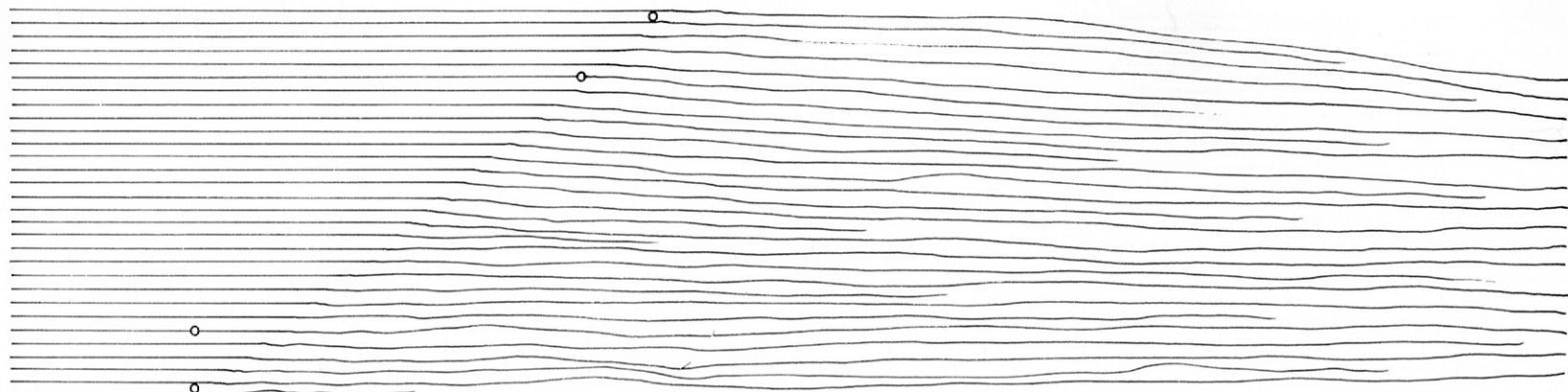

1

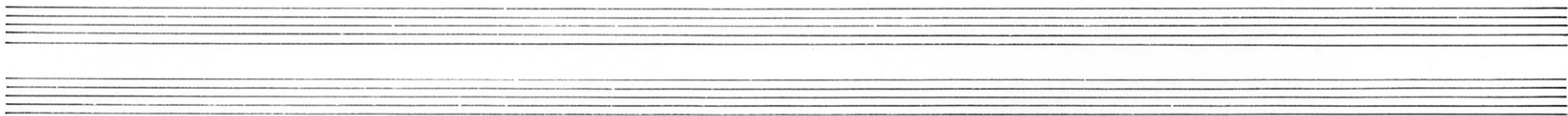
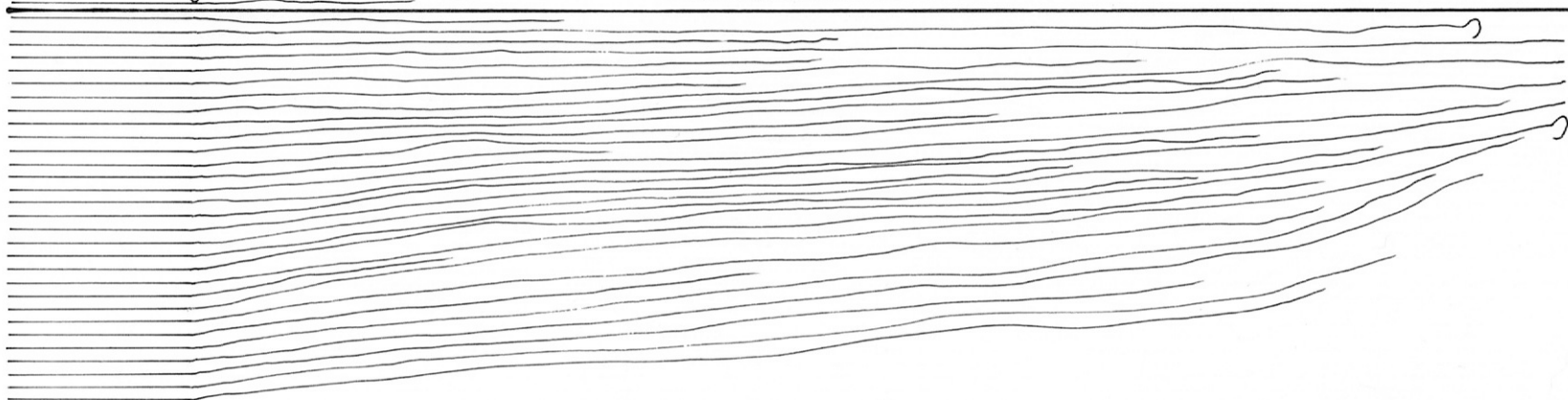

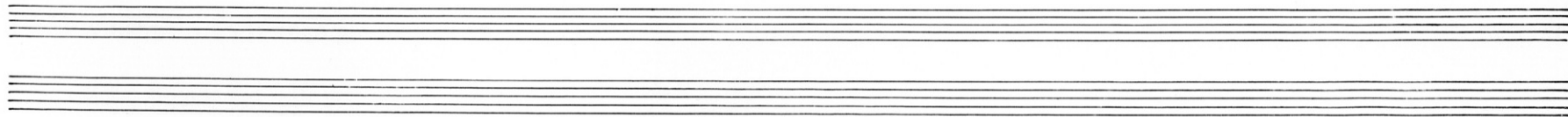
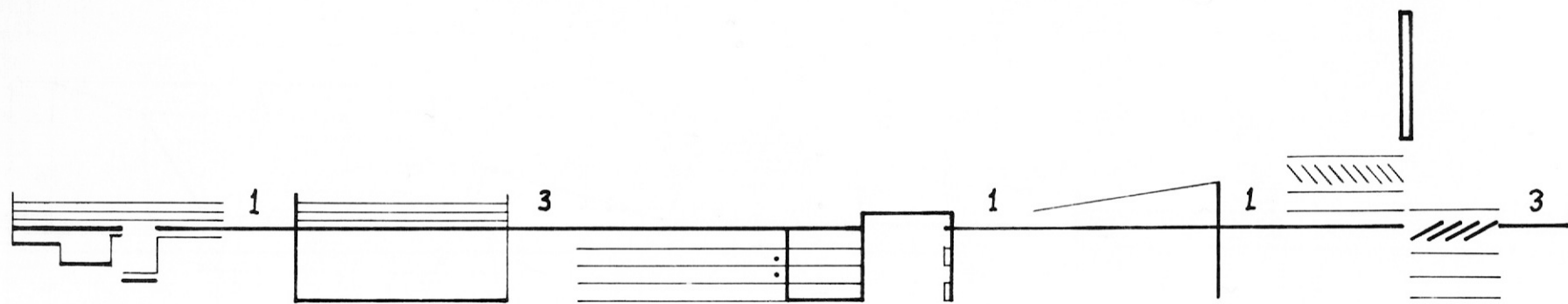

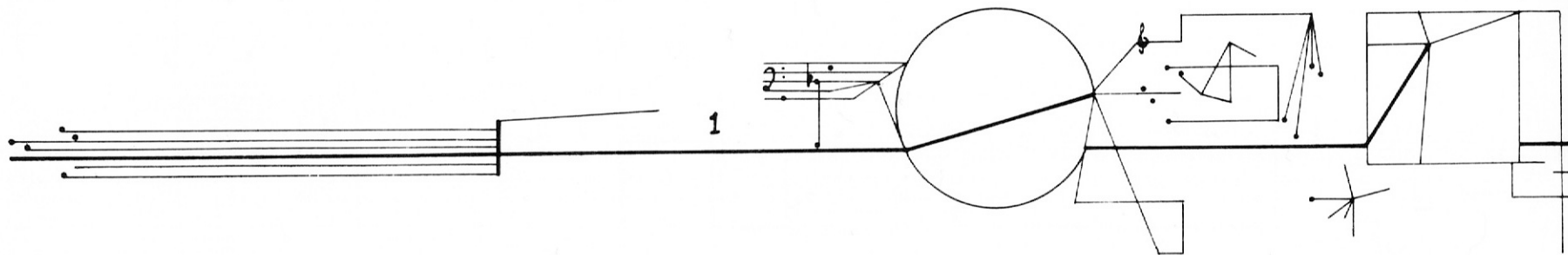

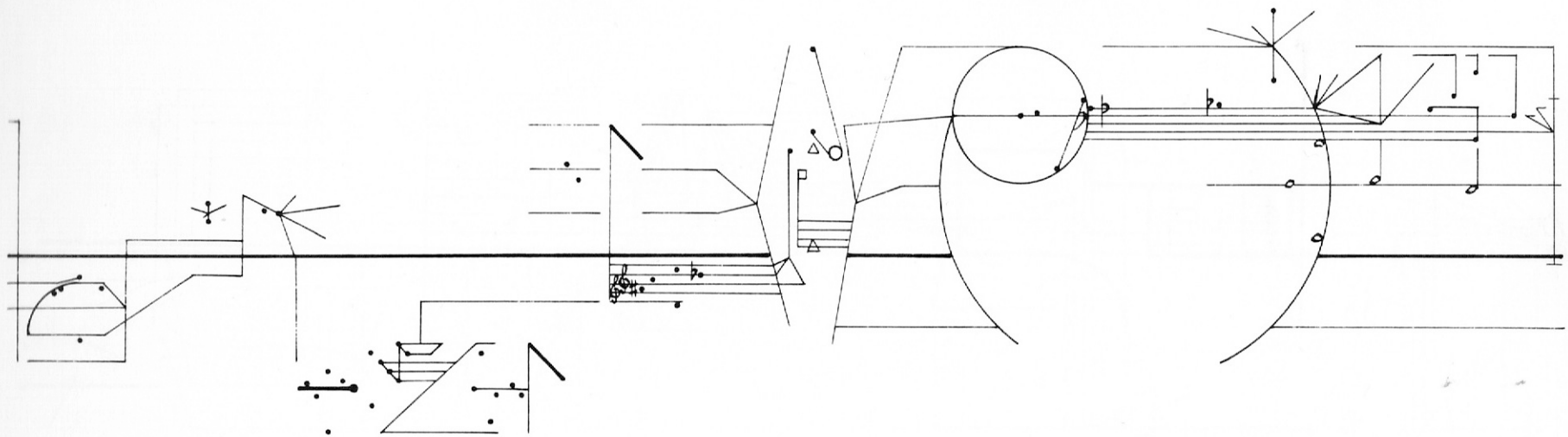

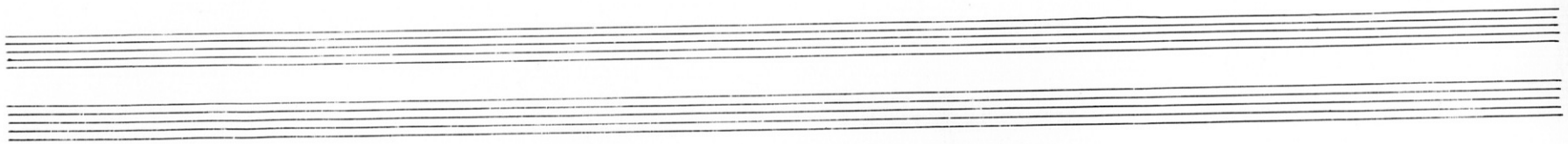
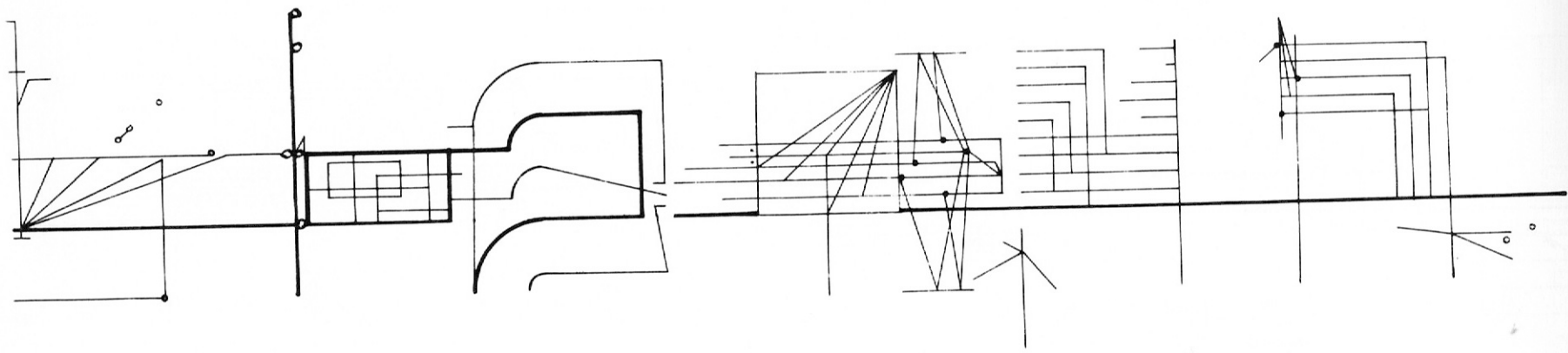

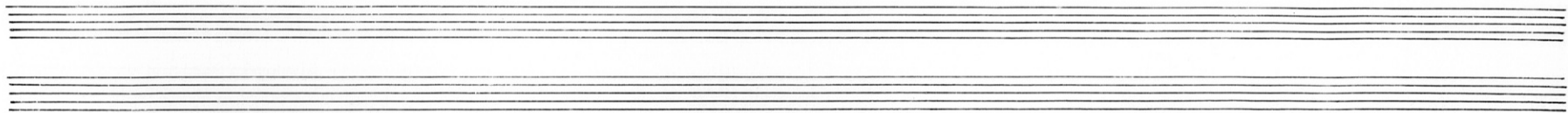
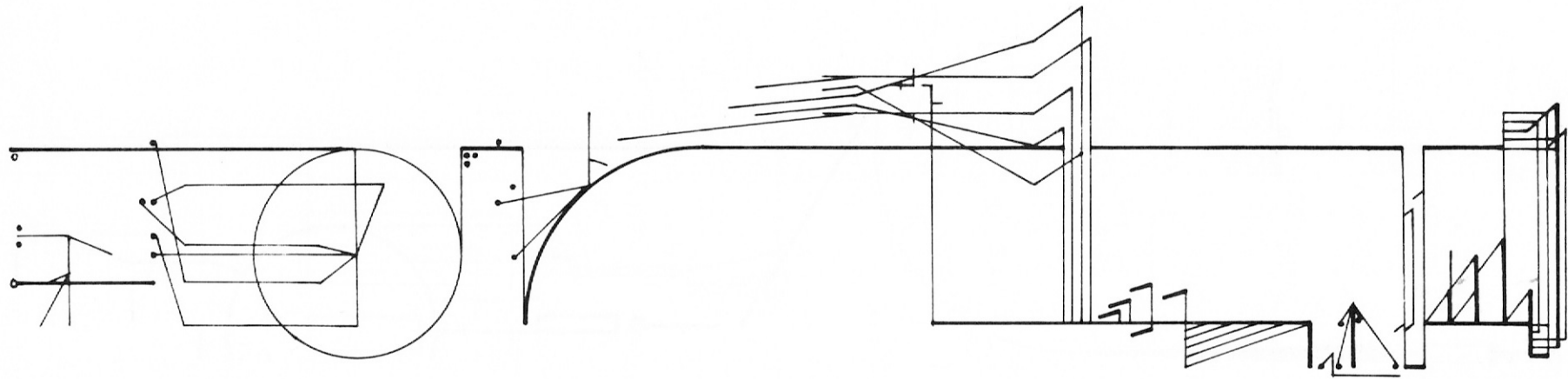

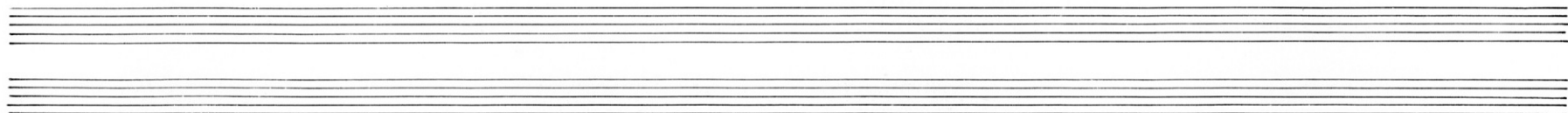
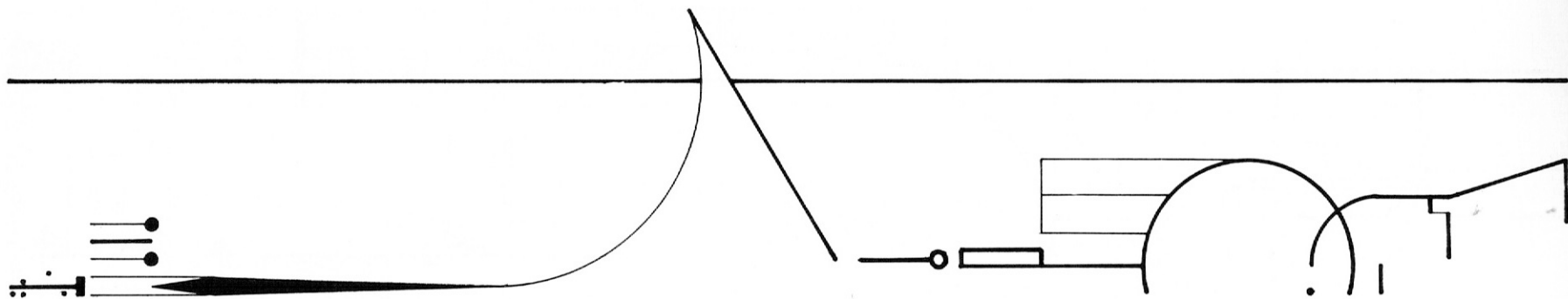

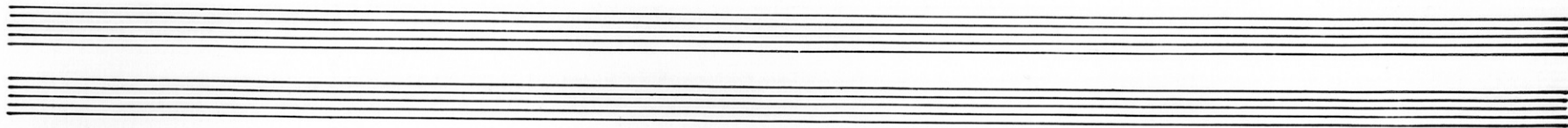
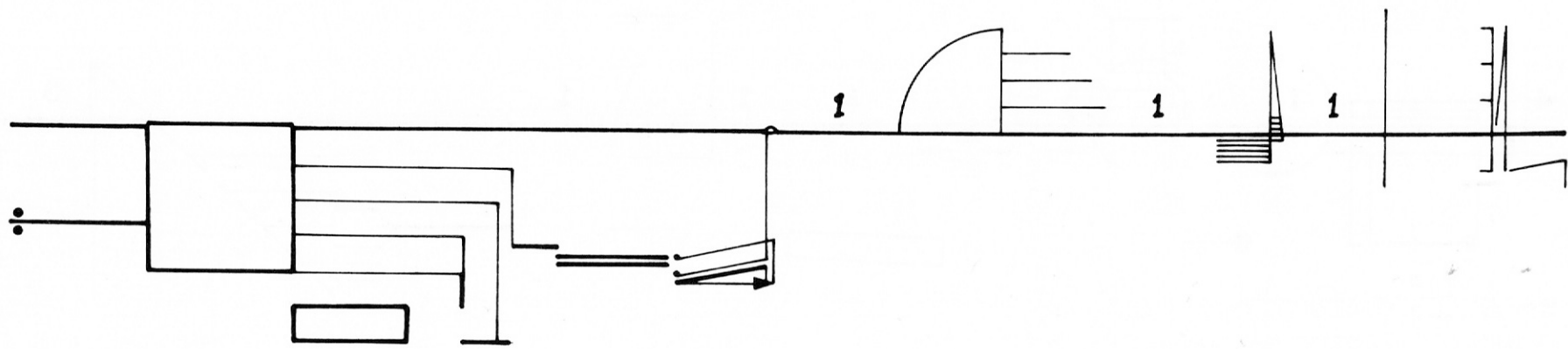

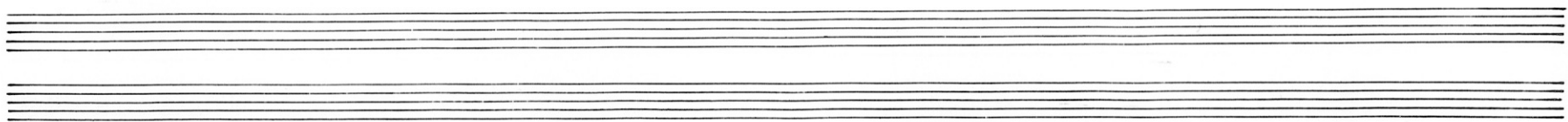
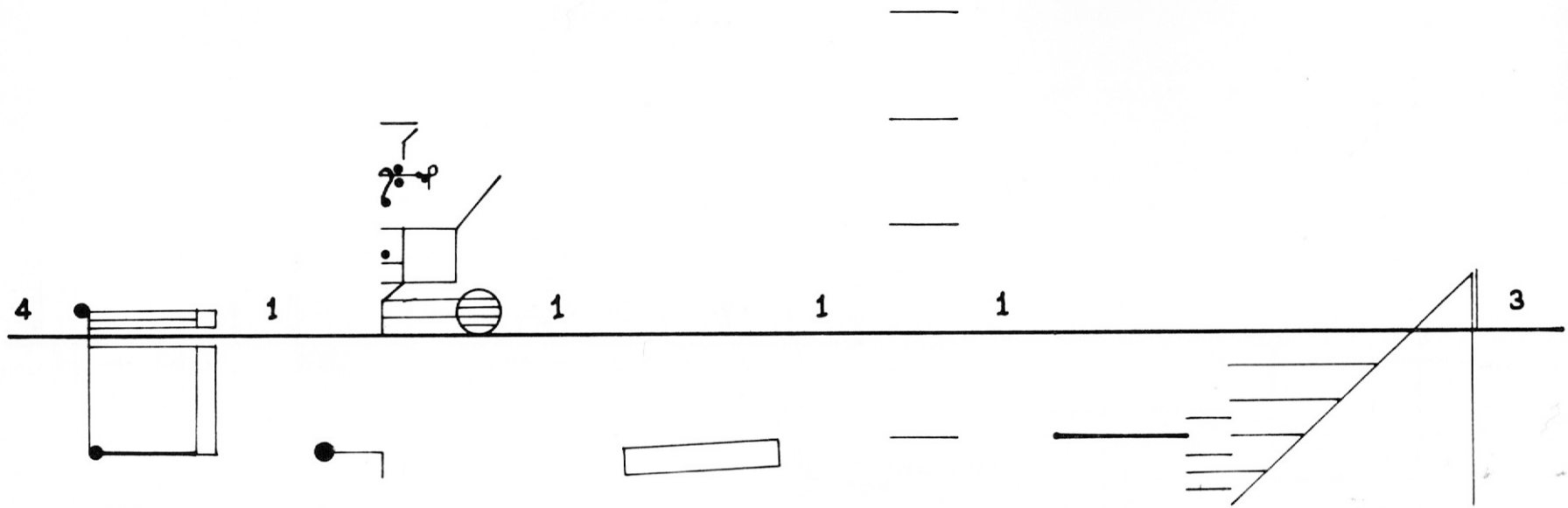

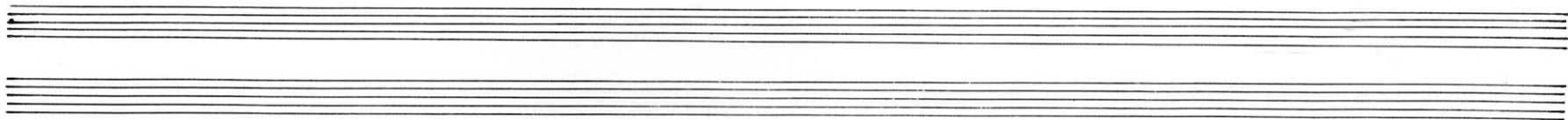
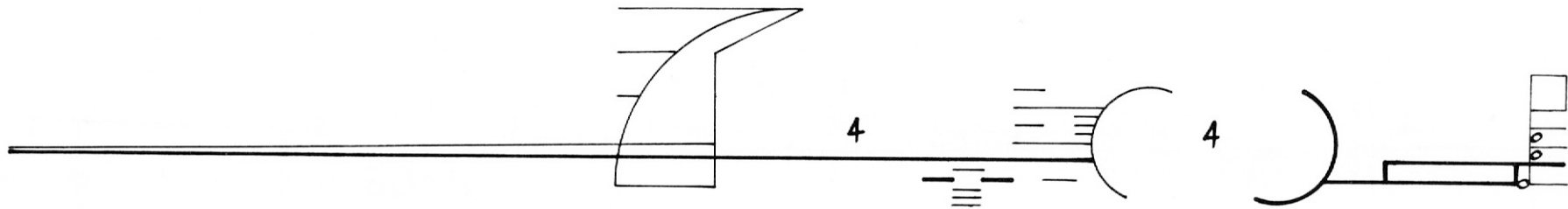

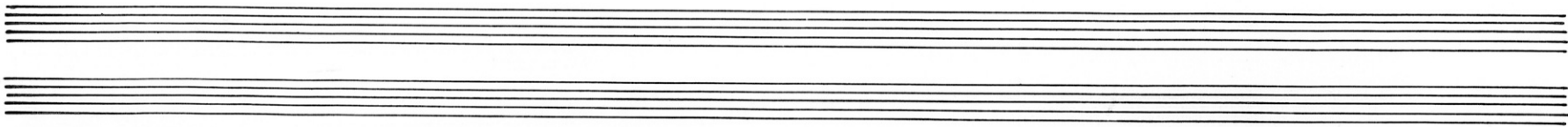
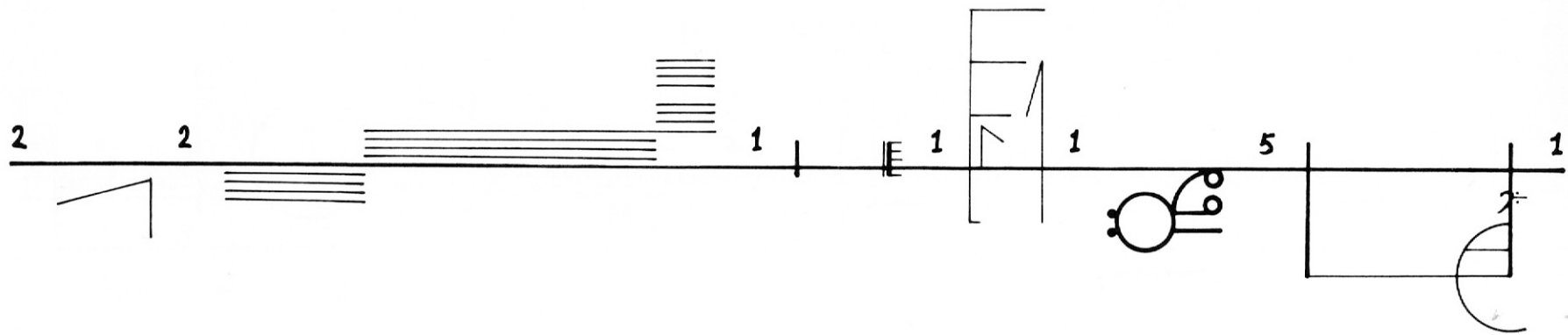

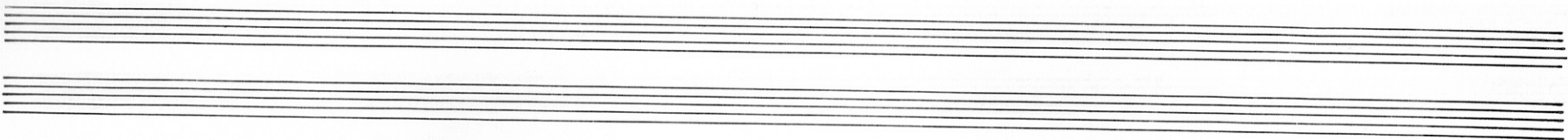
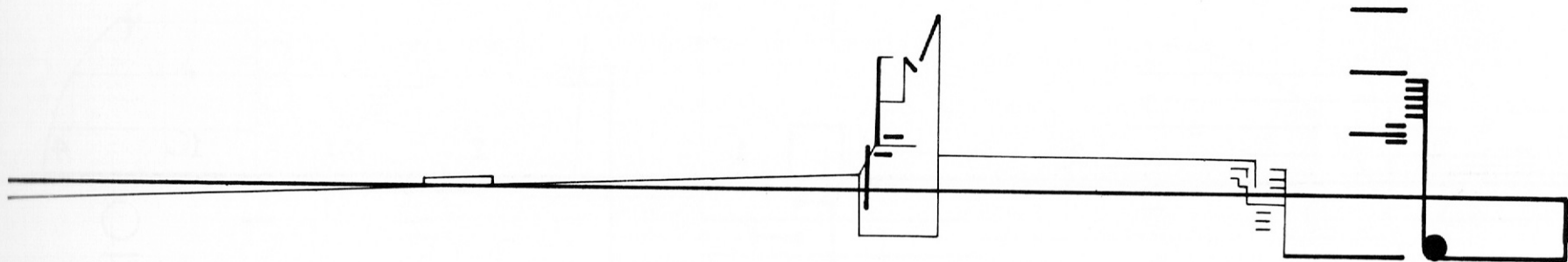

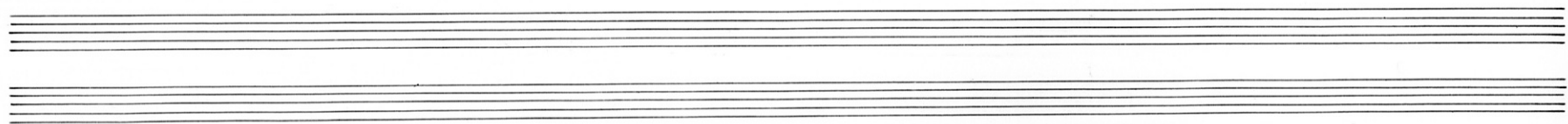
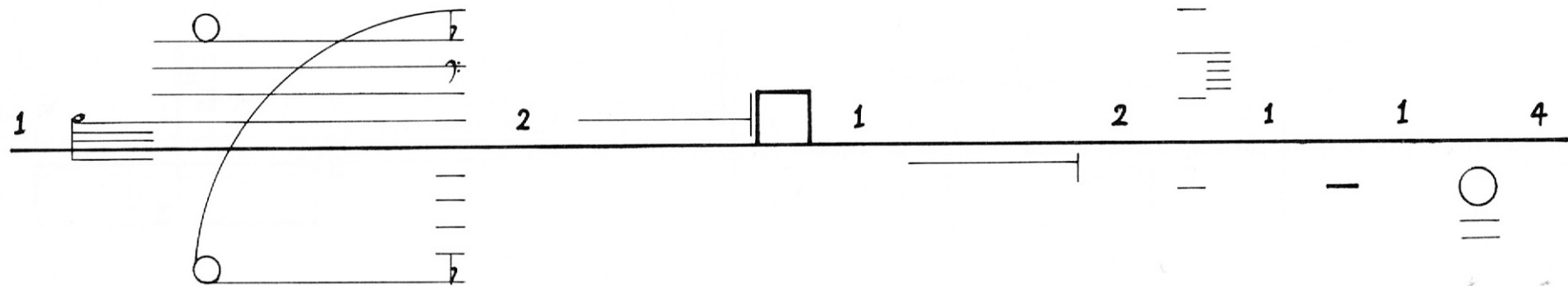

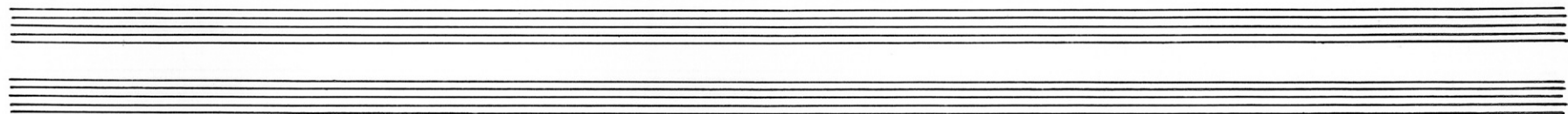
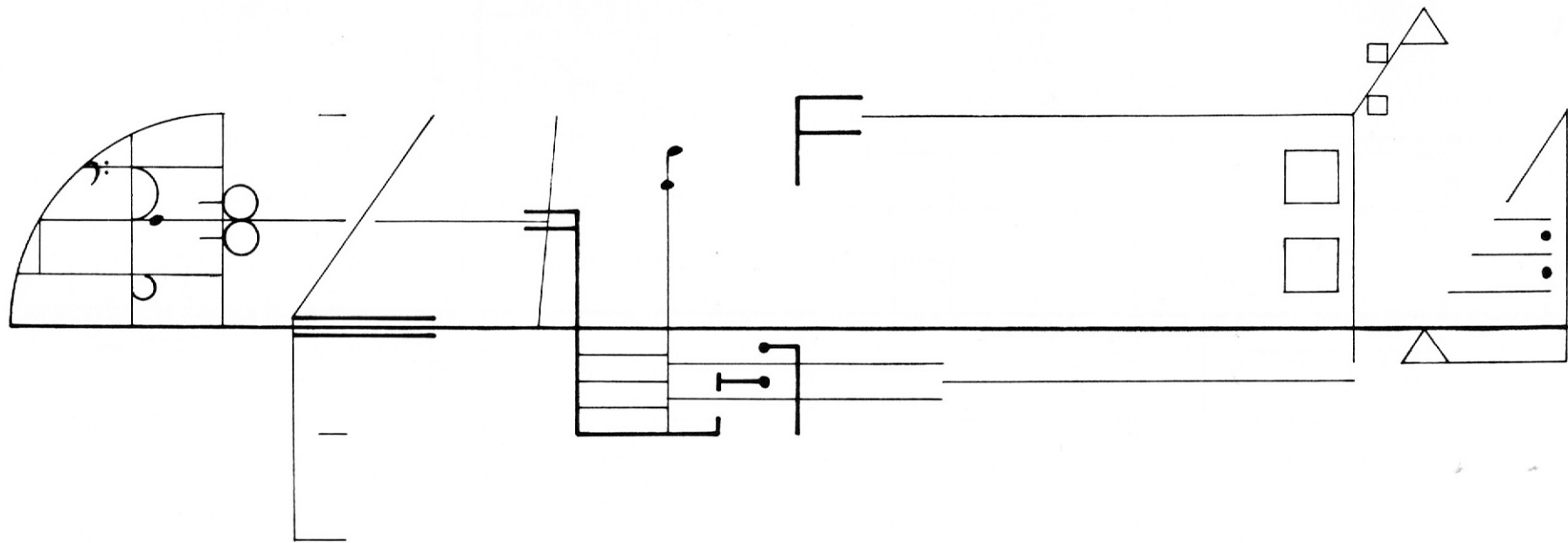

#

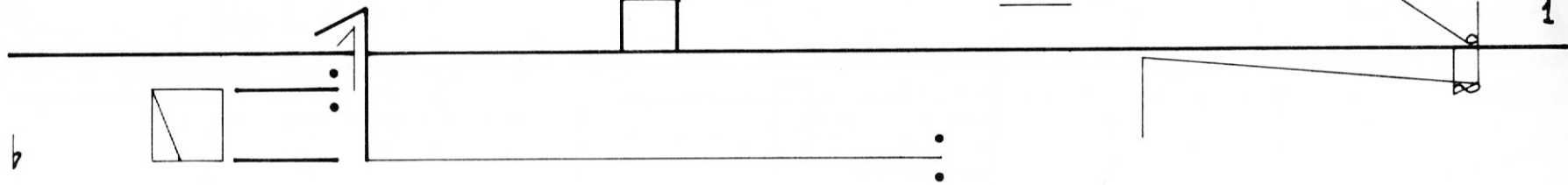
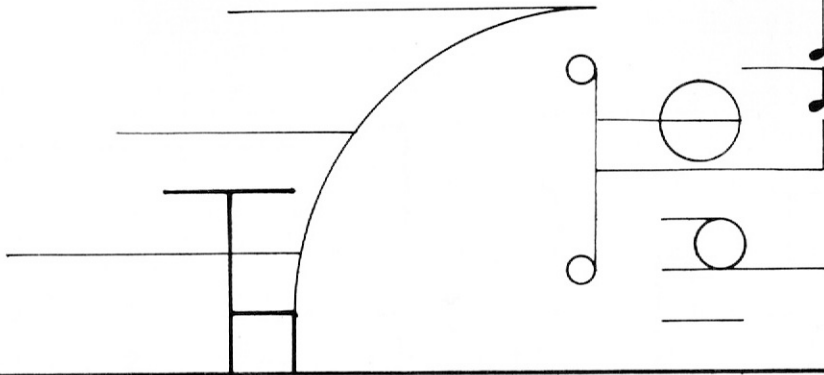
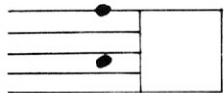

b

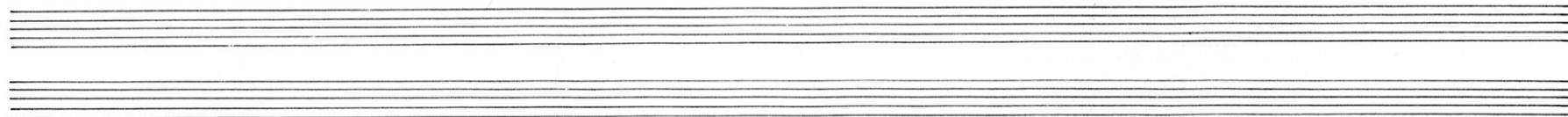

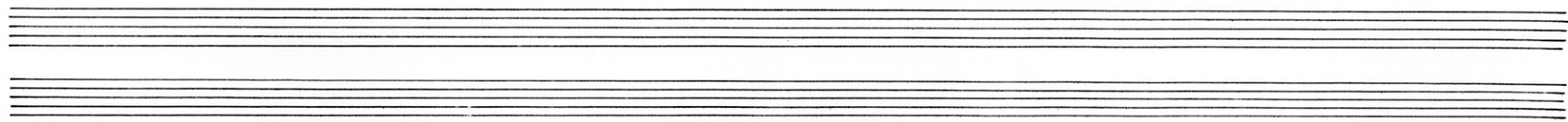
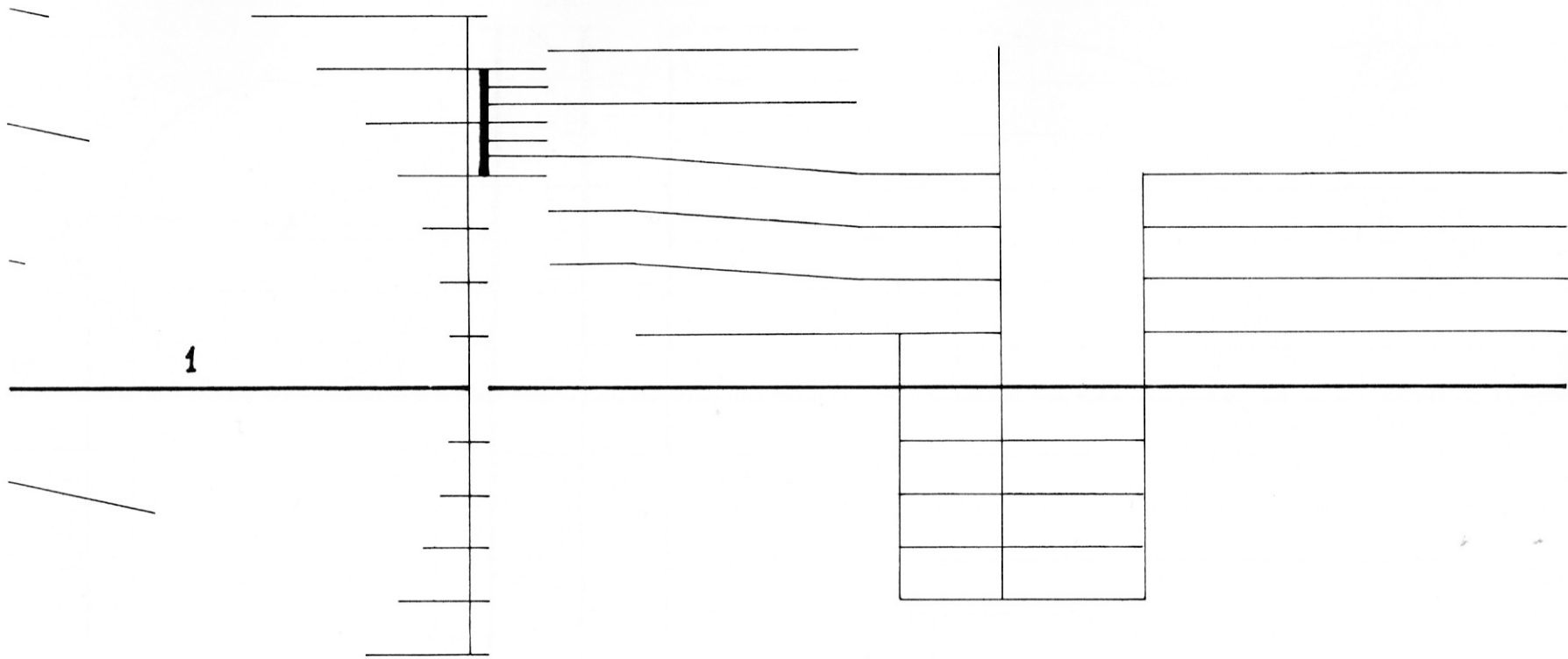

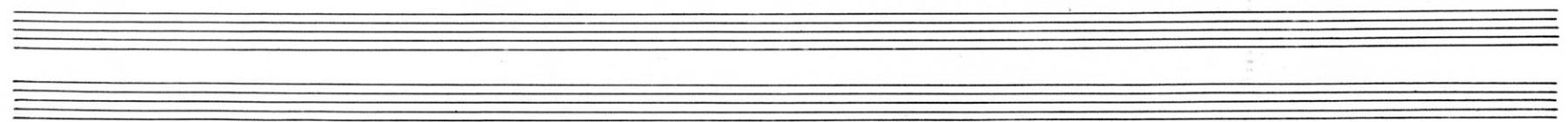
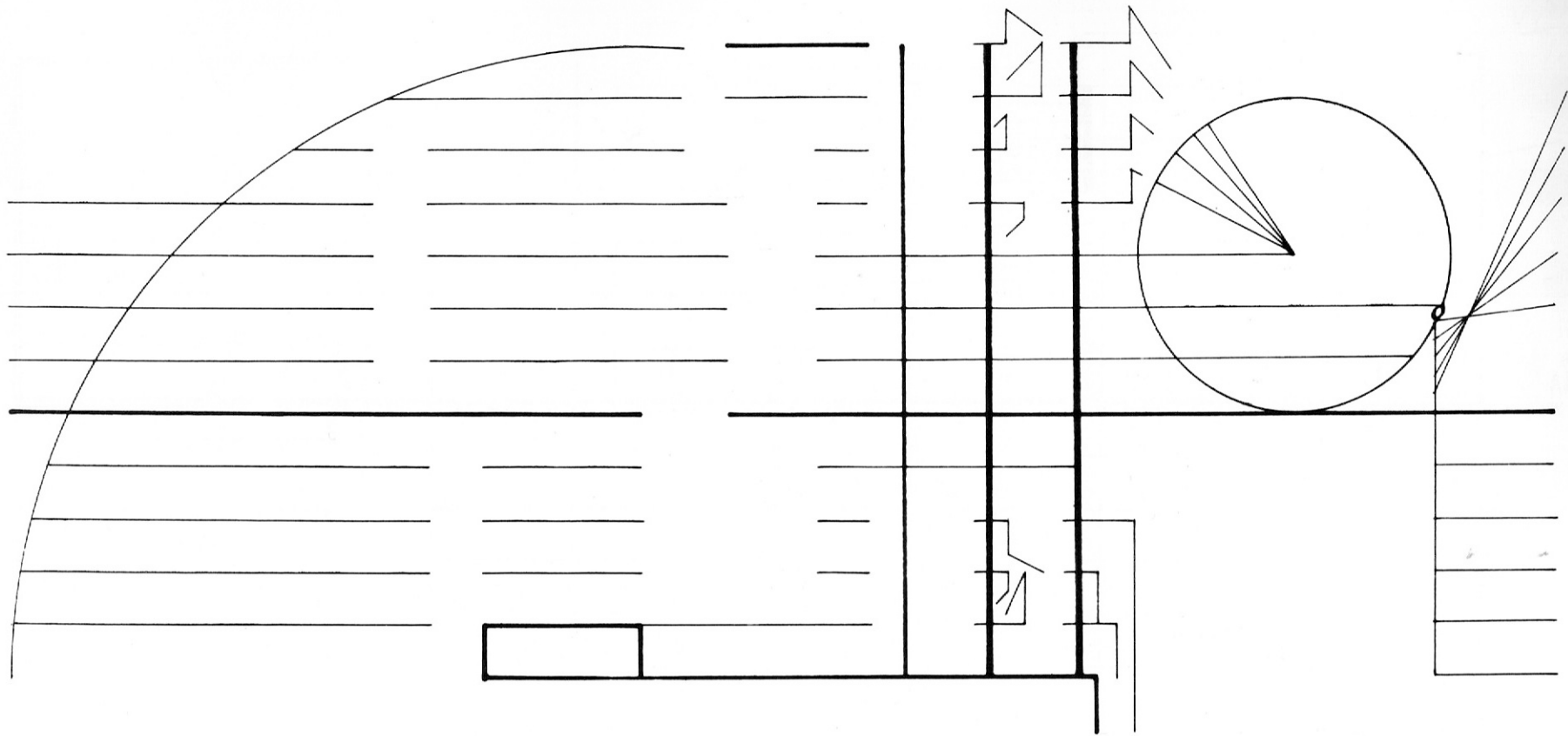

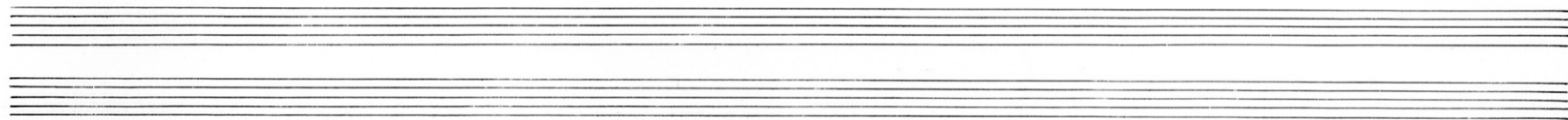
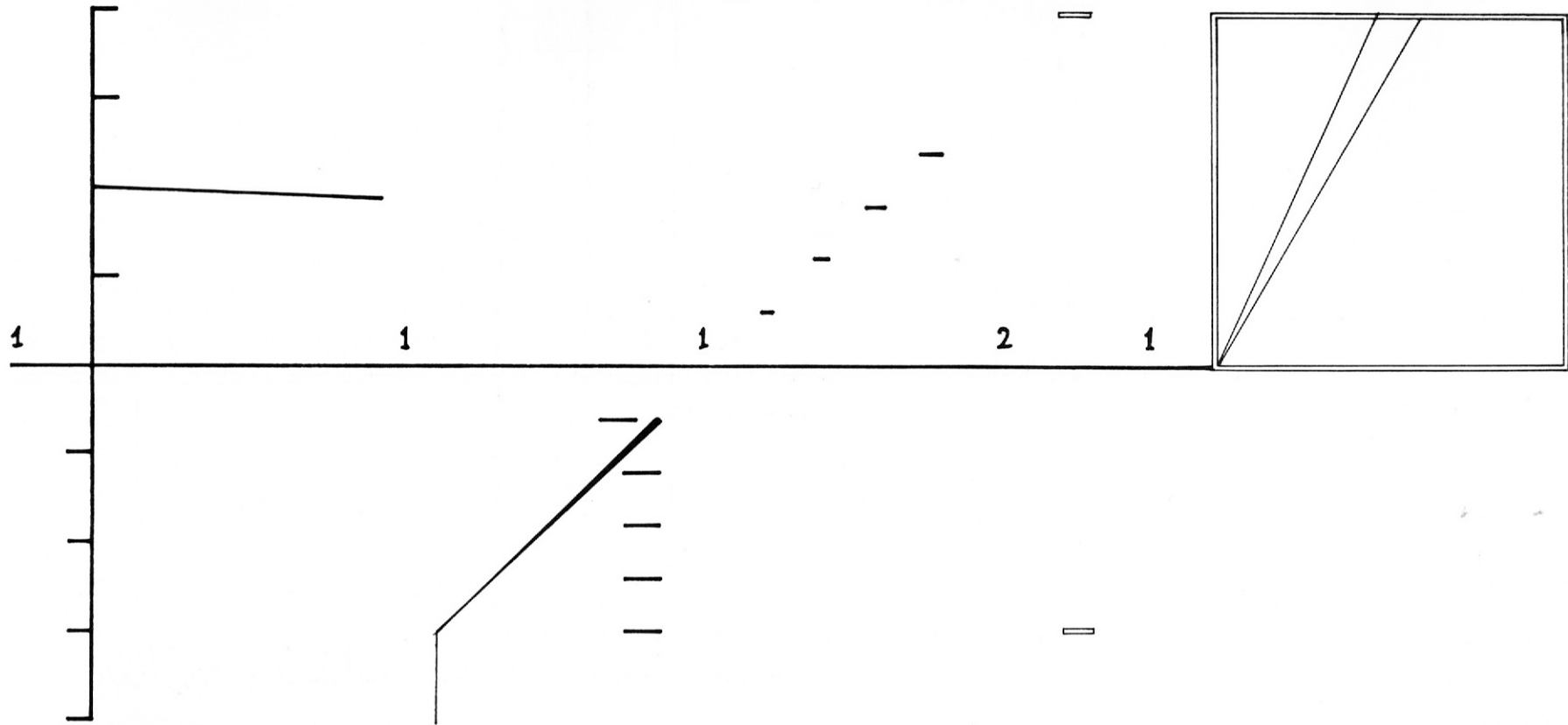

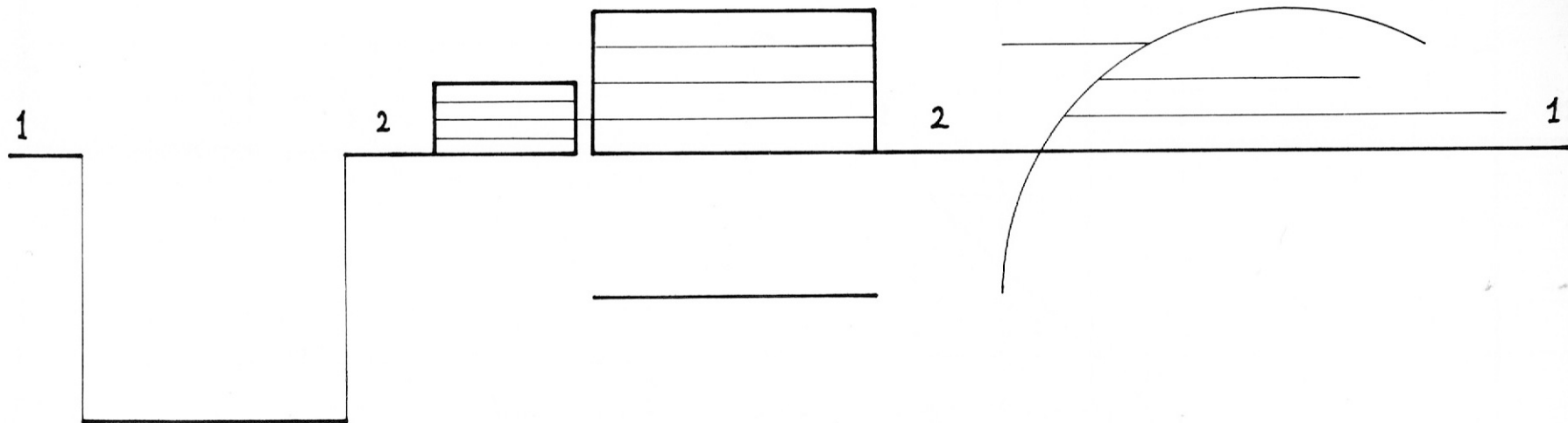

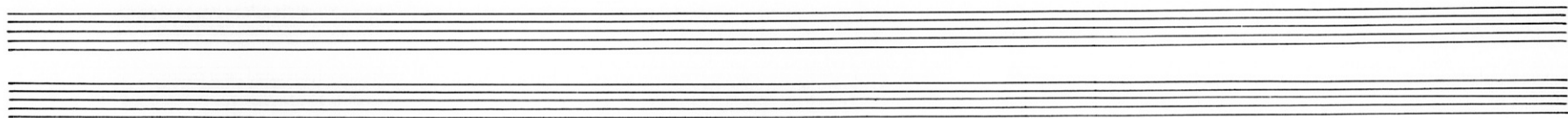
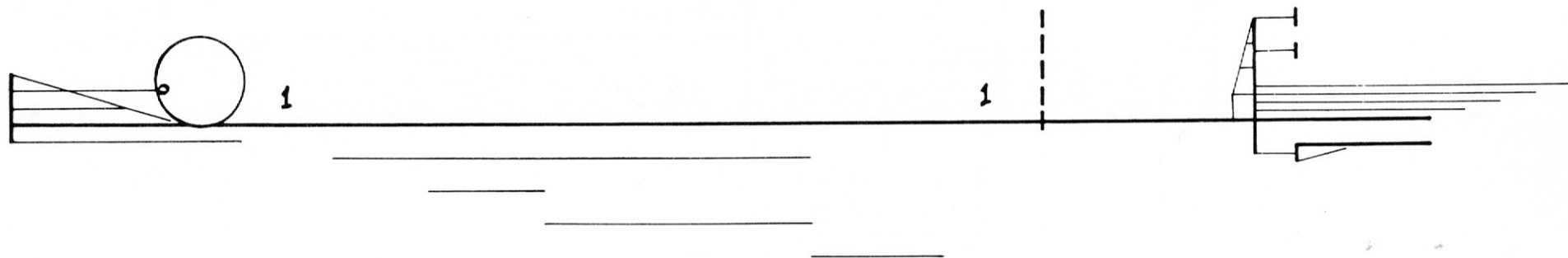

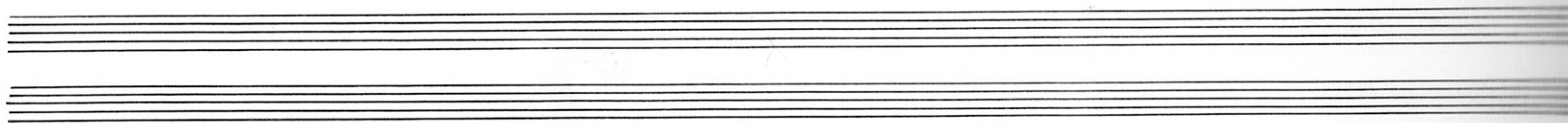
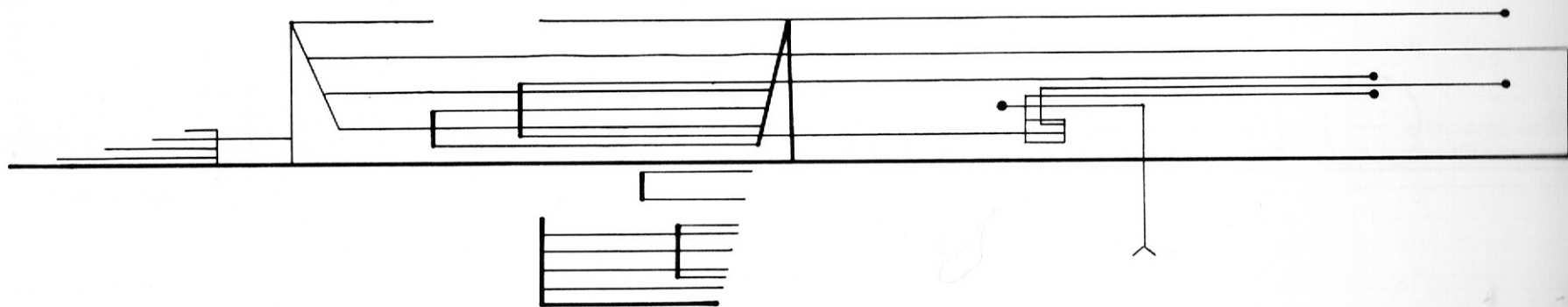

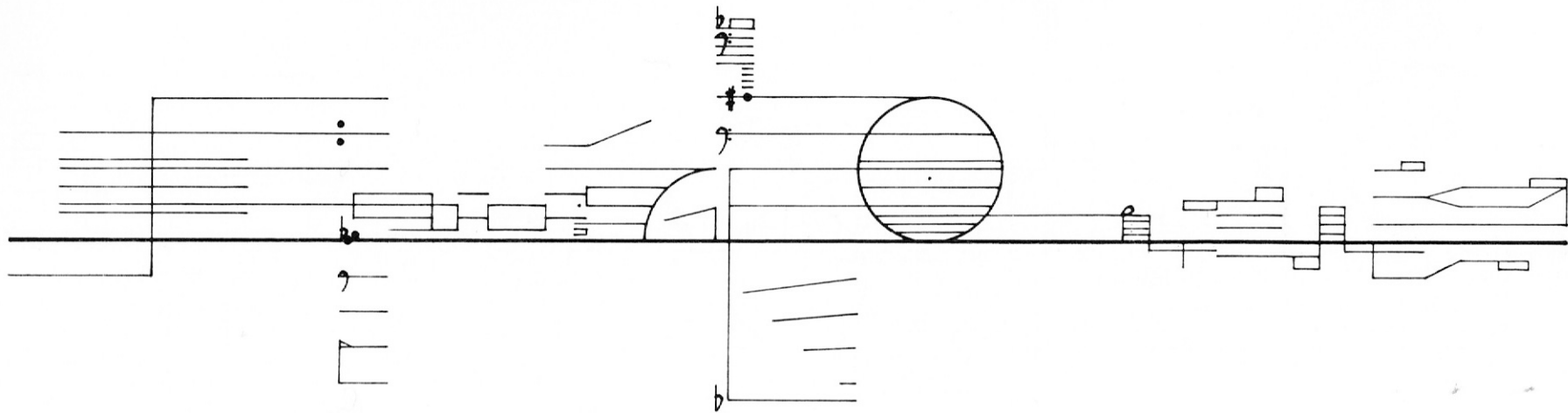

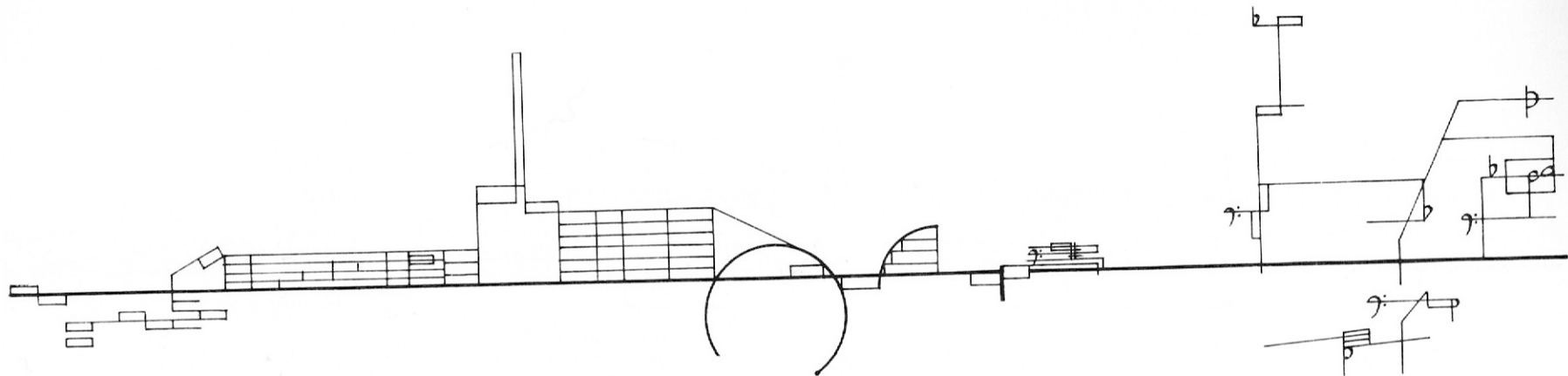

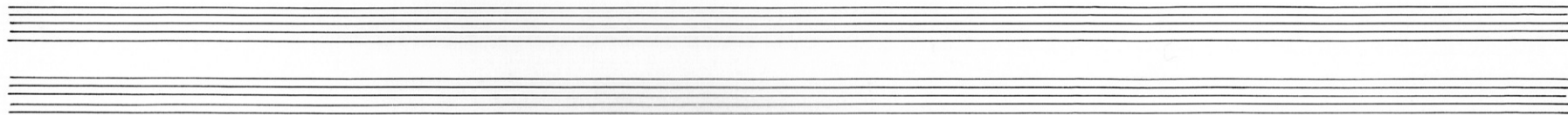
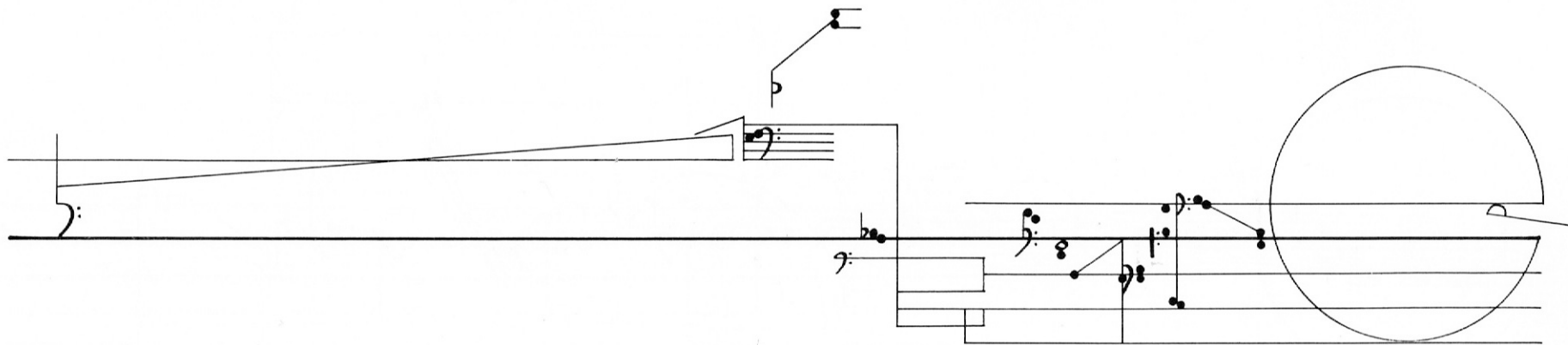

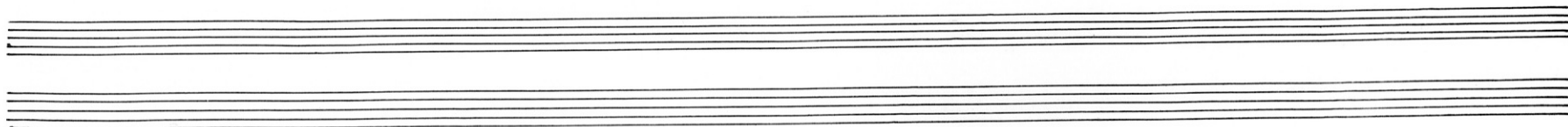
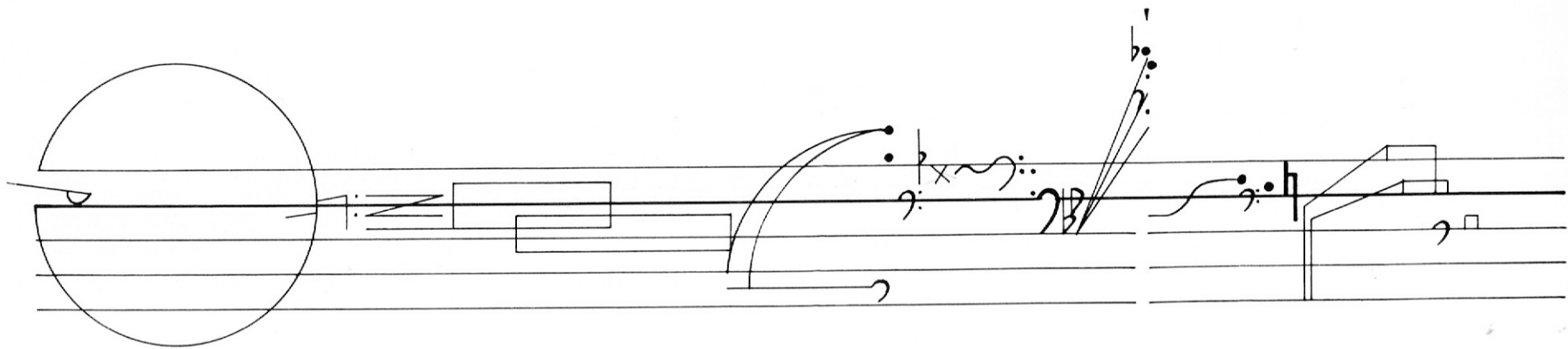

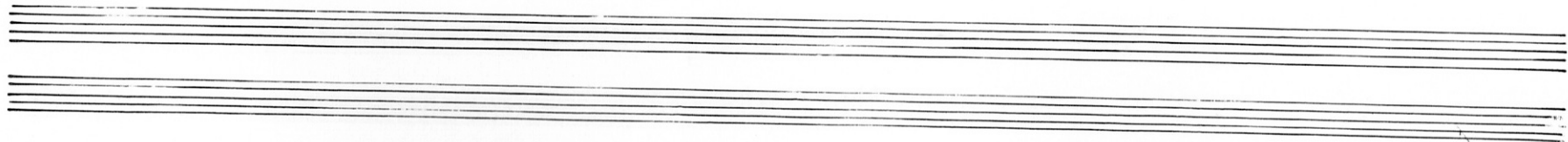
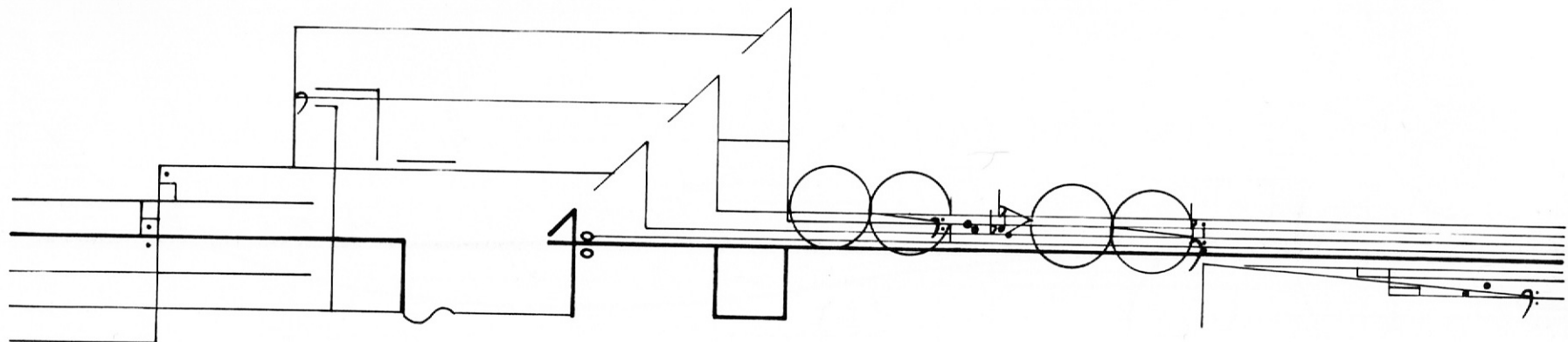

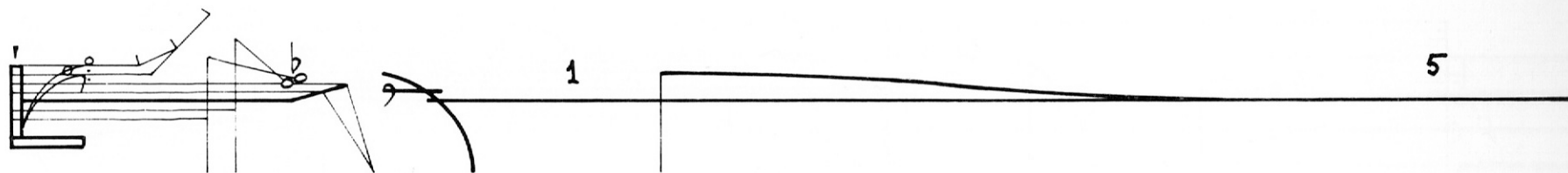

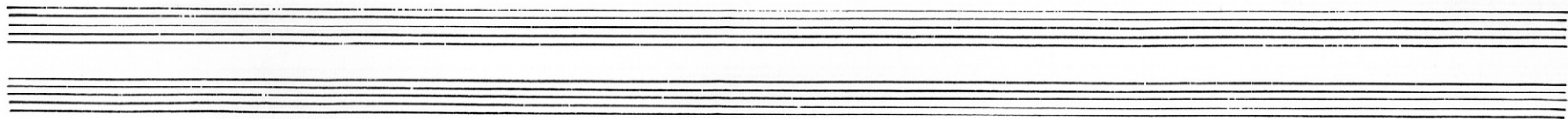
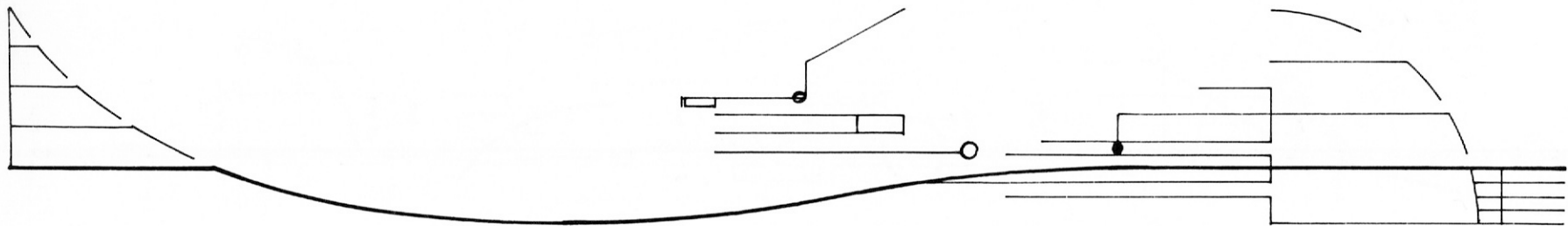

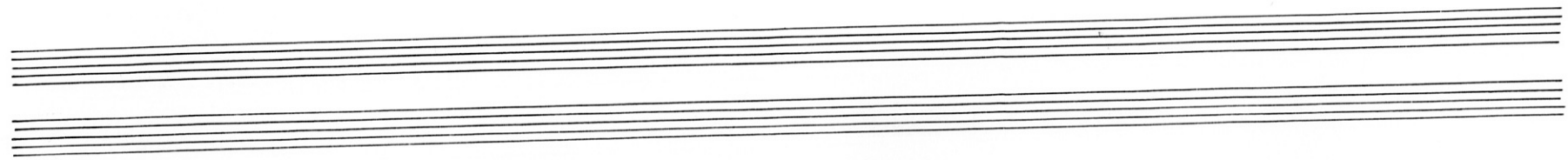
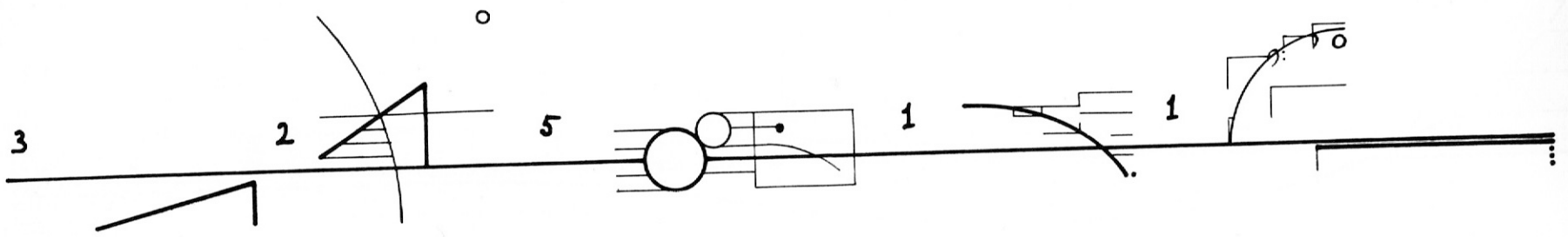

1 2 1

This section contains handwriting practice on a set of four horizontal lines. The numbers '1', '2', and '1' are positioned above the lines. The first '1' is above a solid line with a dot below it. The '2' is above a solid line with a dot below it. The second '1' is above a solid line with a dot below it. A vertical line is drawn from the top line to the bottom line, passing through the '2'. To the right, there are several horizontal lines of varying styles: solid, dashed, and dotted, some with small gaps or breaks.

This section contains handwriting practice on a set of four horizontal lines. It features several horizontal lines of varying styles: solid, dashed, and dotted. Some lines are slightly slanted. There are also several small dots scattered around the lines, some appearing to be part of the practice or as artifacts.

This section contains two sets of empty handwriting practice lines, each consisting of four horizontal lines. The lines are evenly spaced and extend across the width of the page.

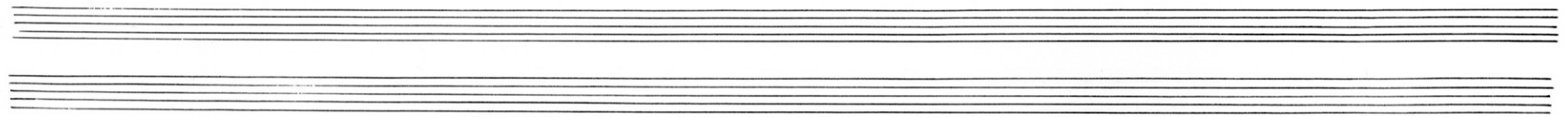
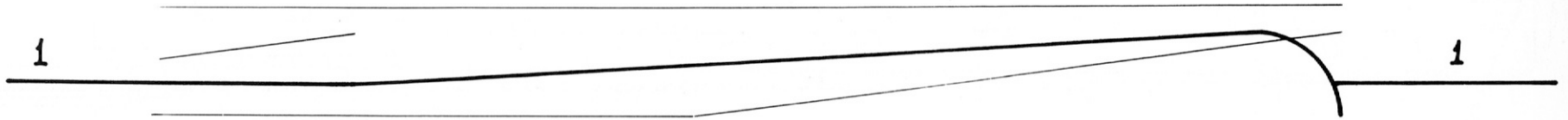

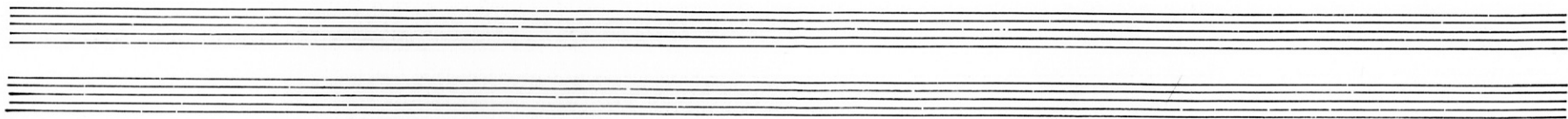
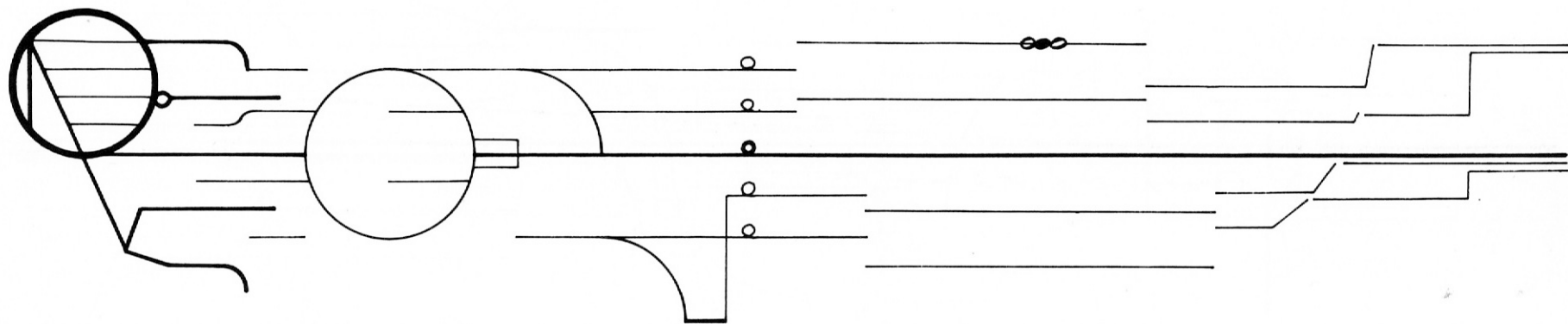

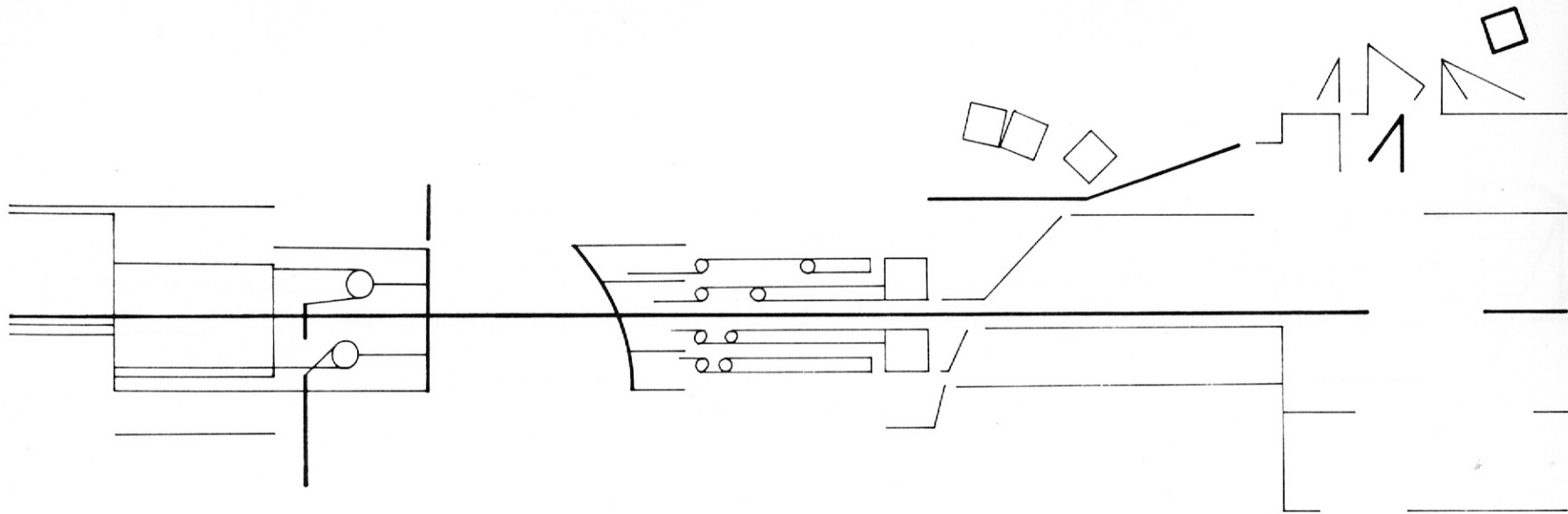

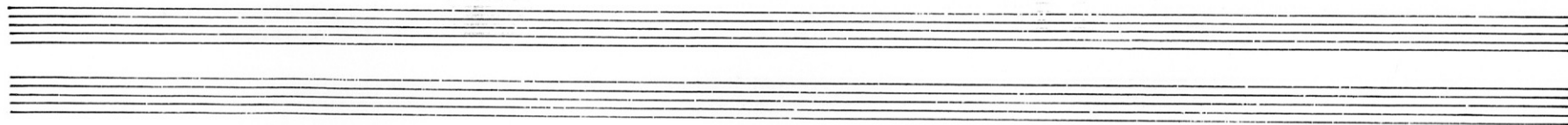
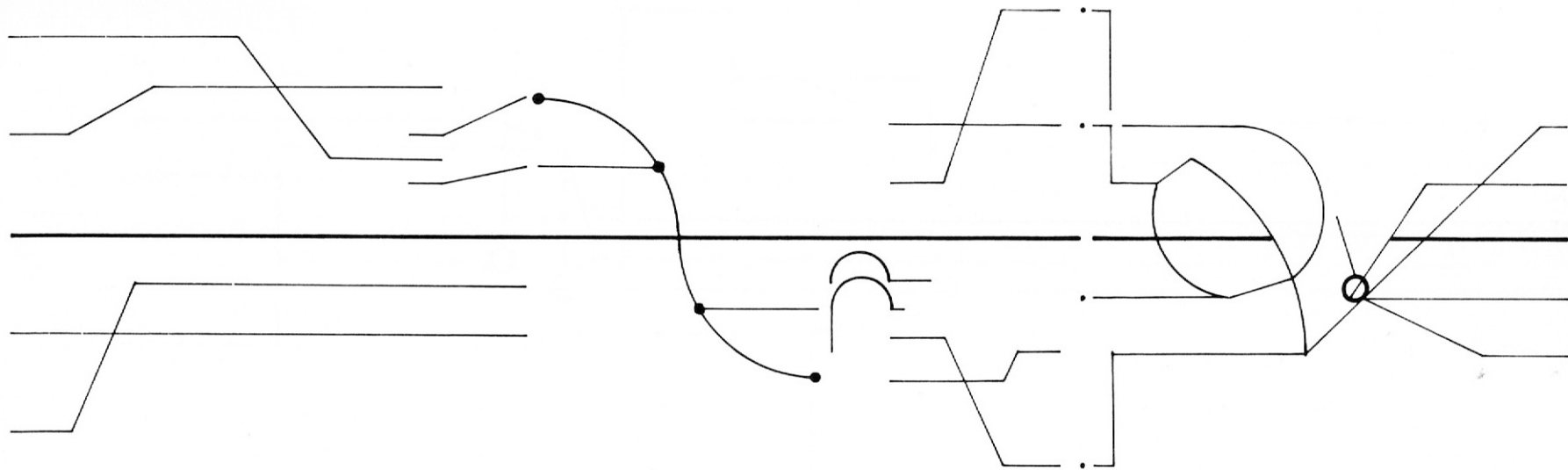

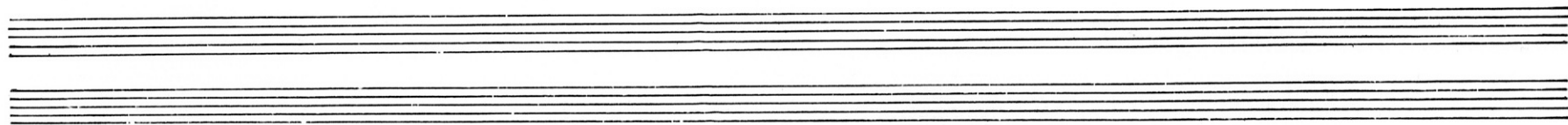
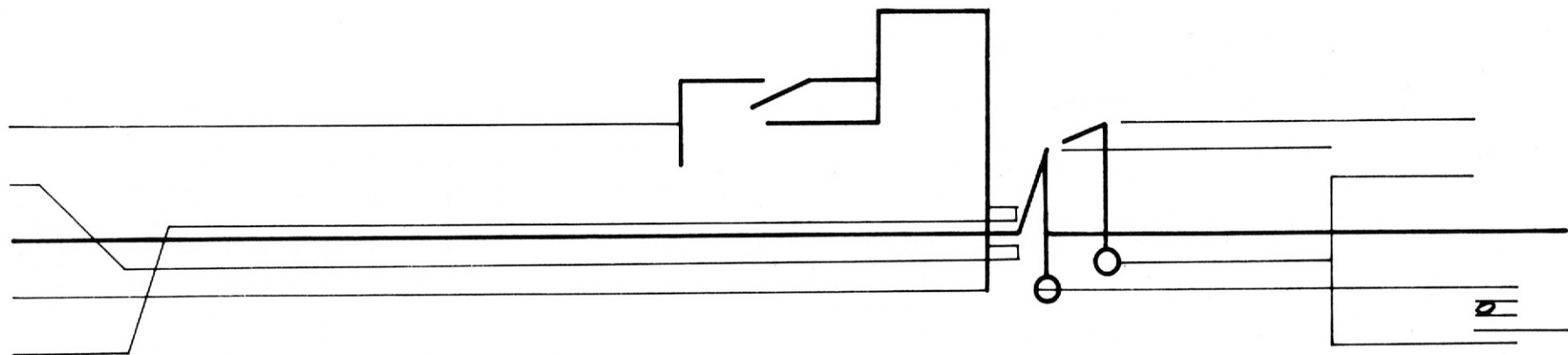

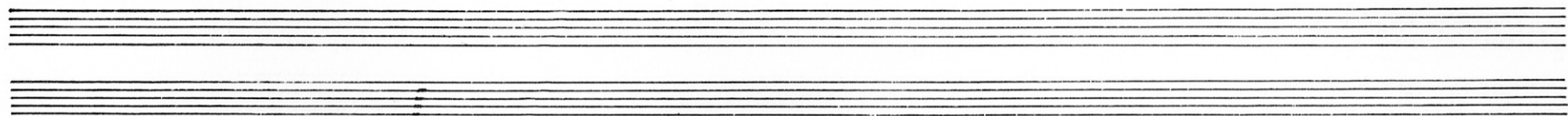
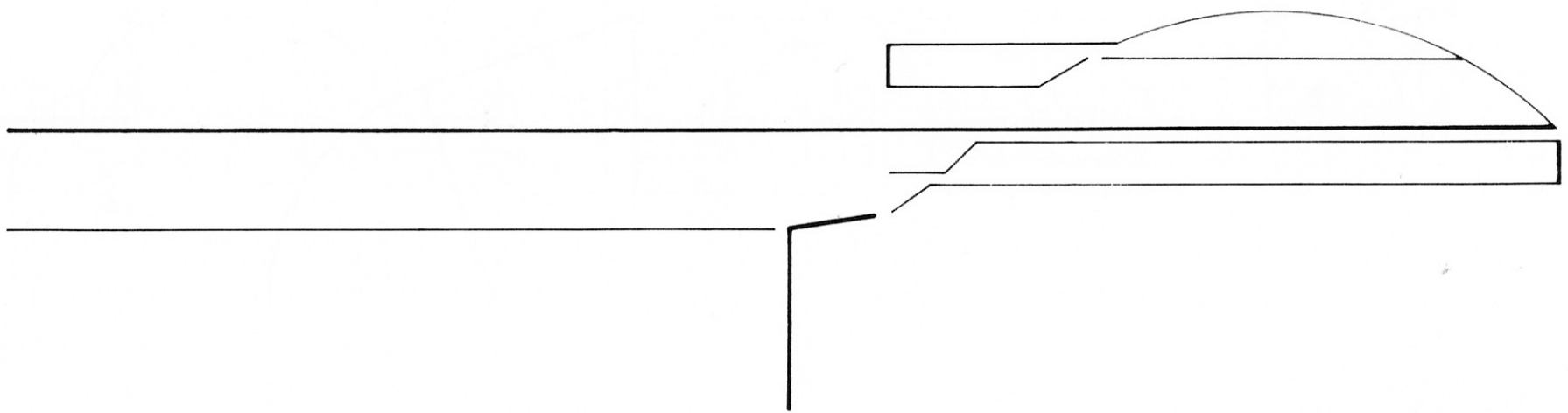

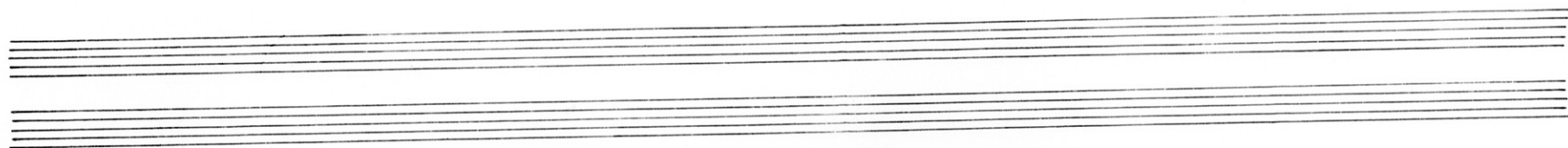
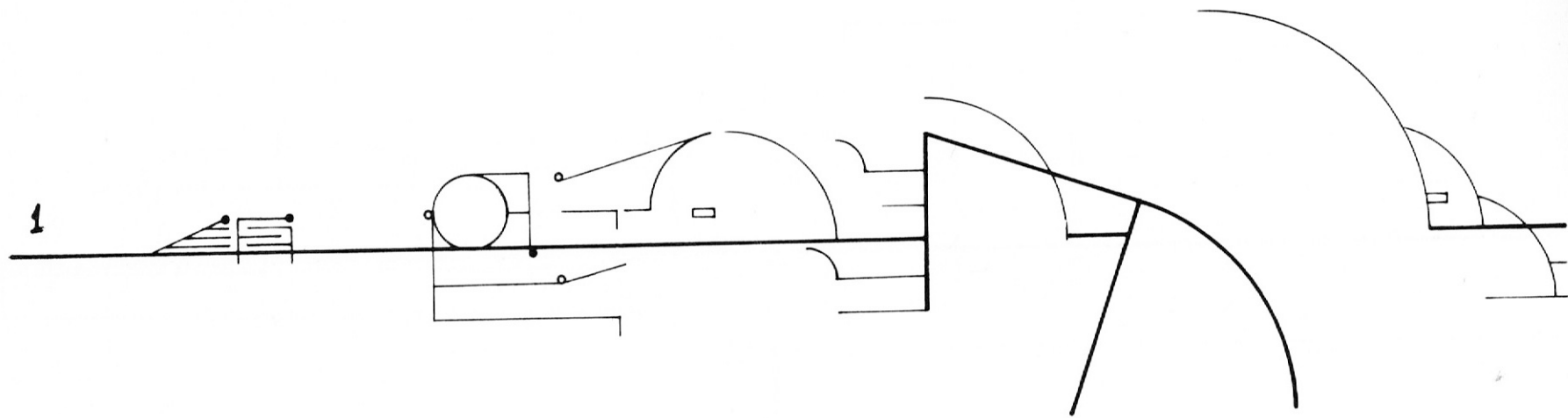

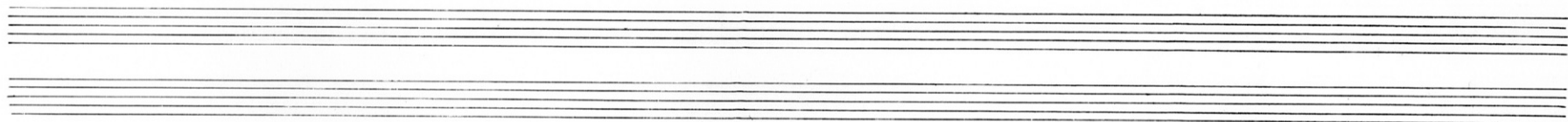
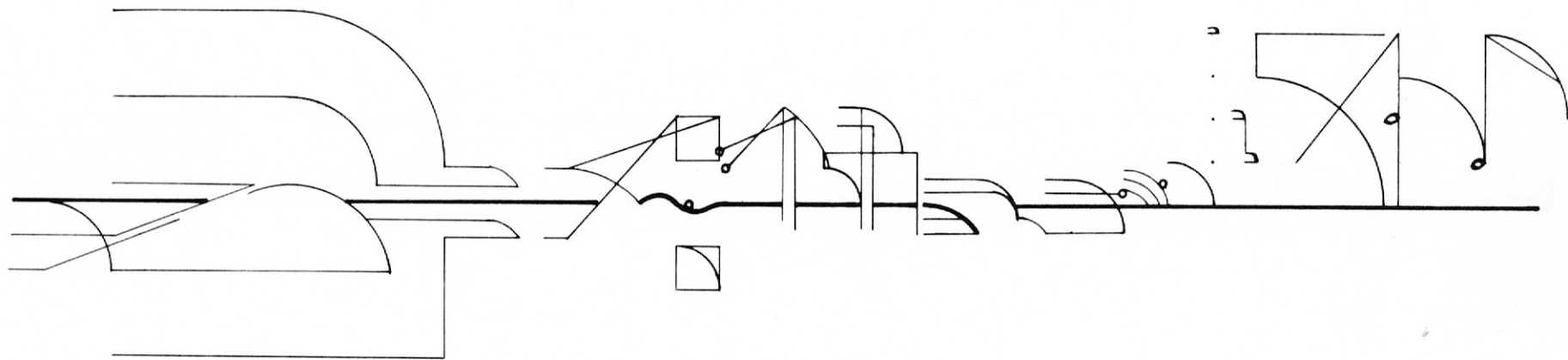

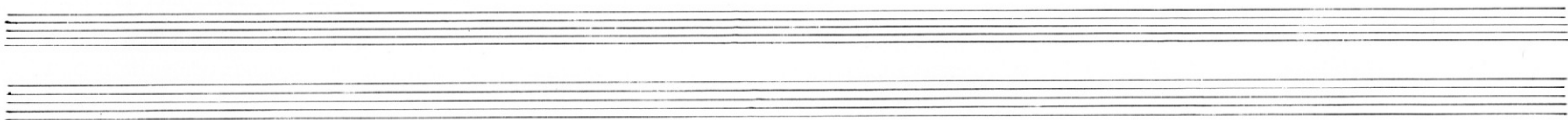
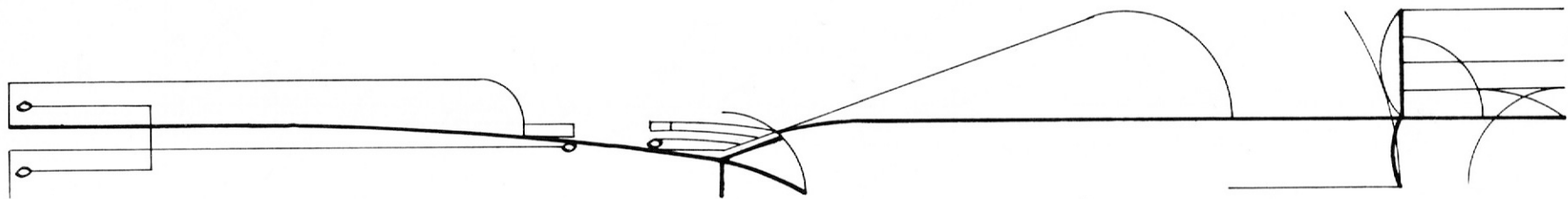

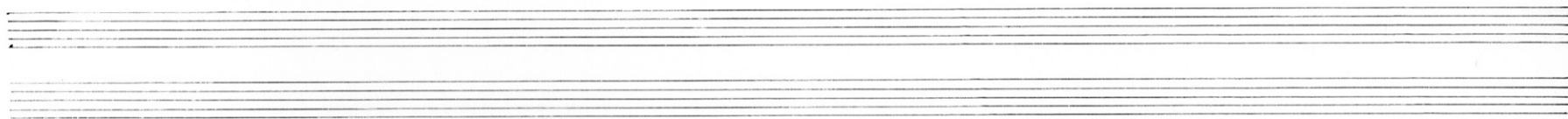
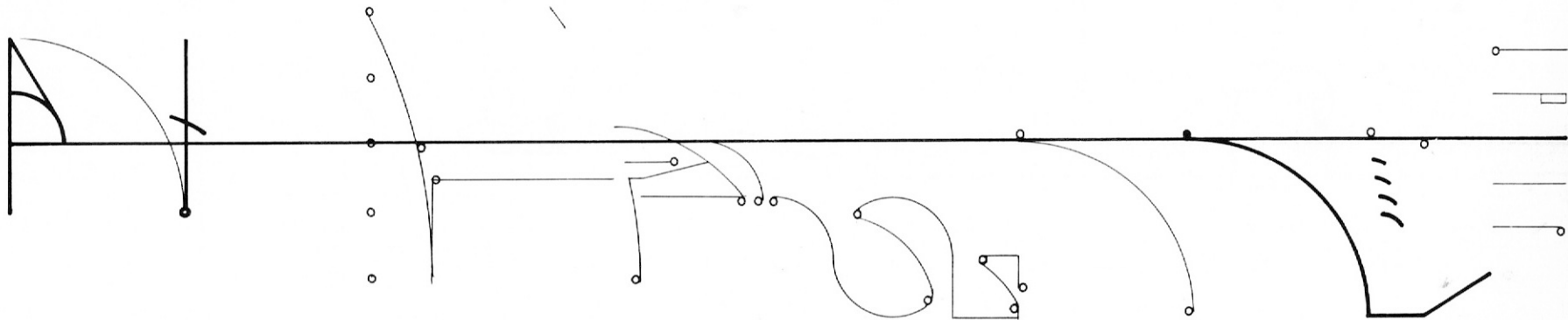

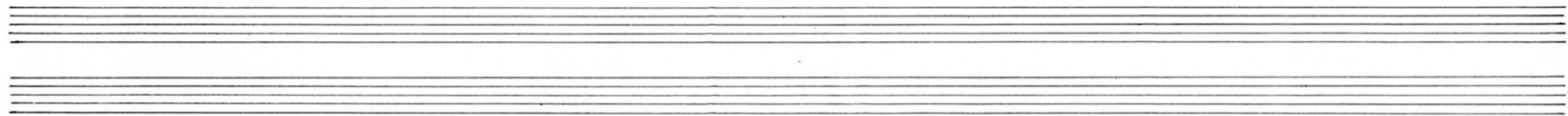
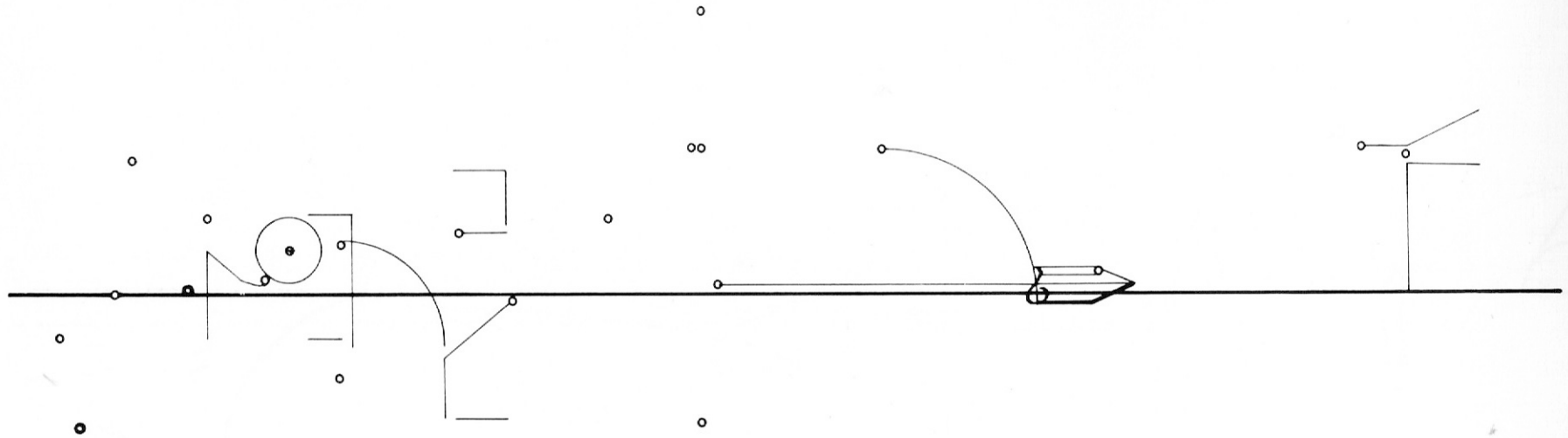

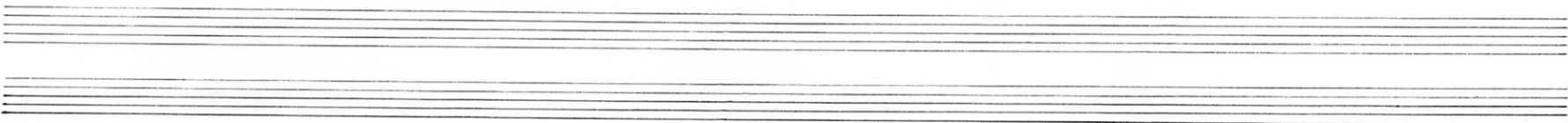
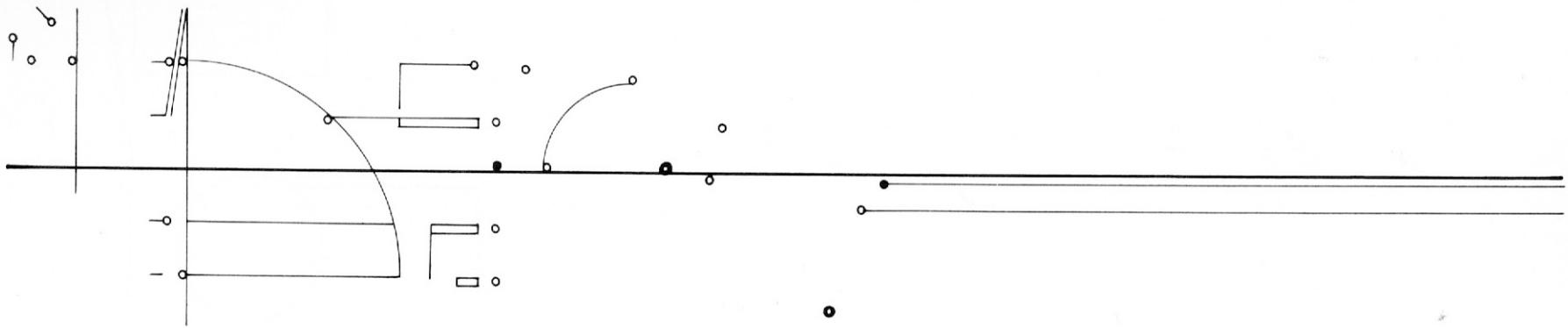

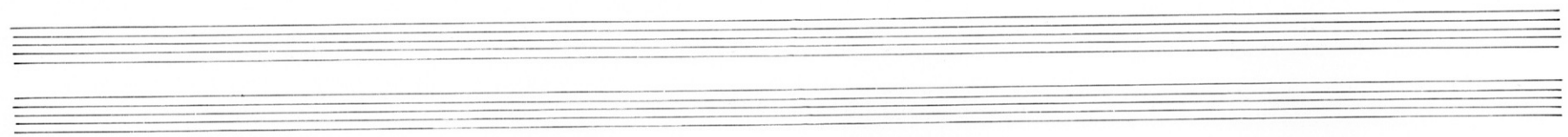
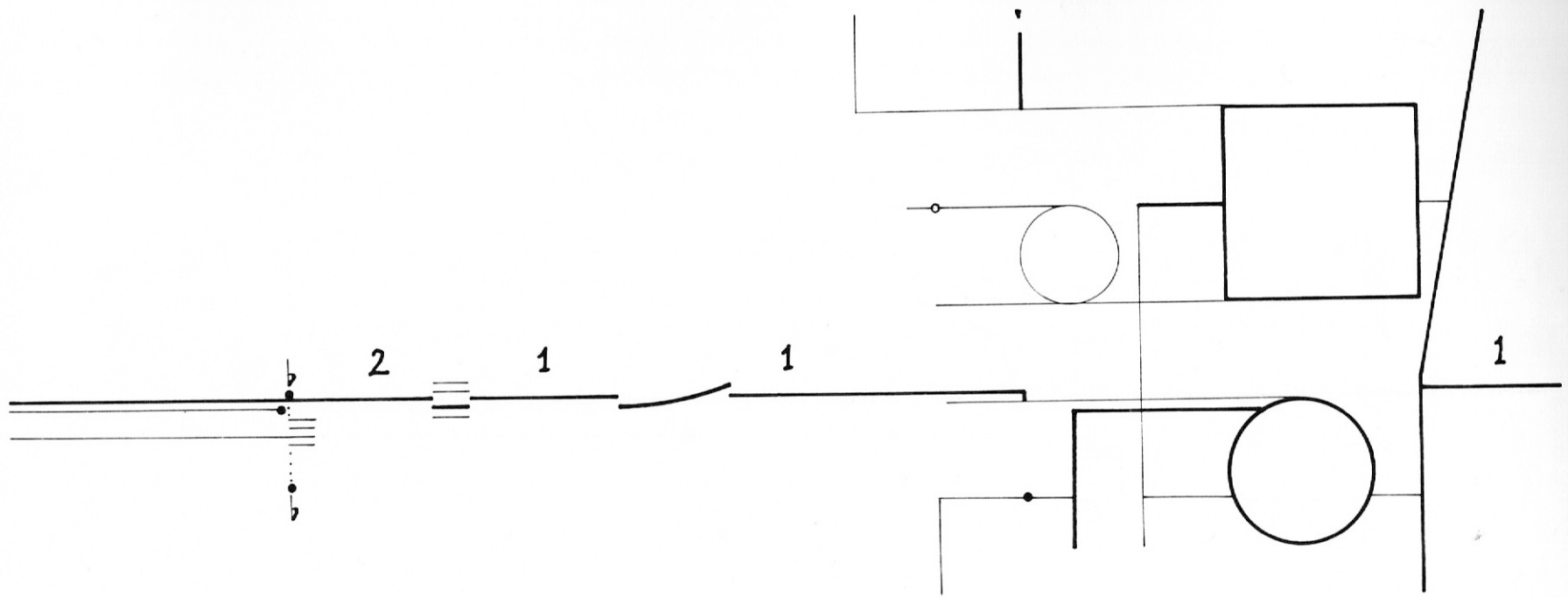

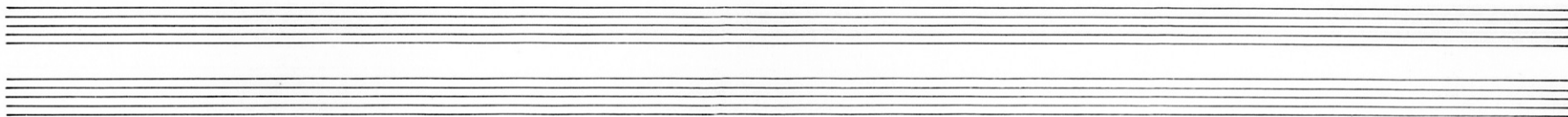
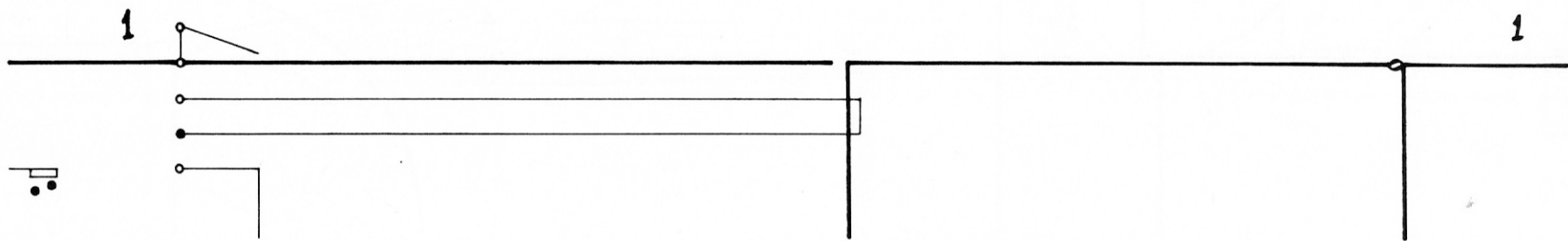

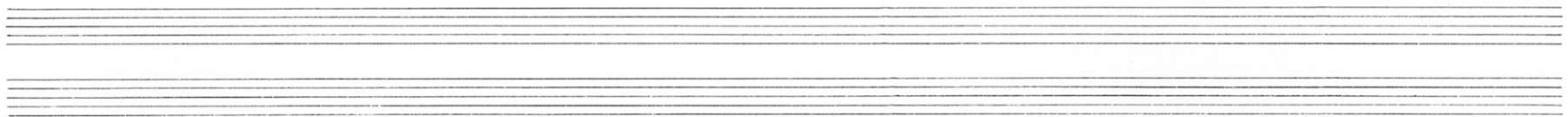
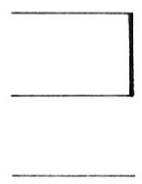
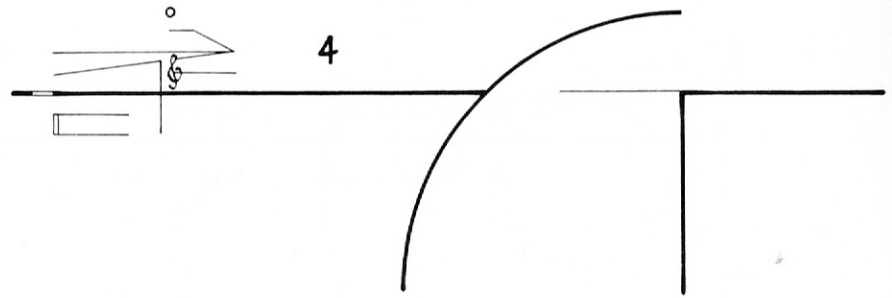
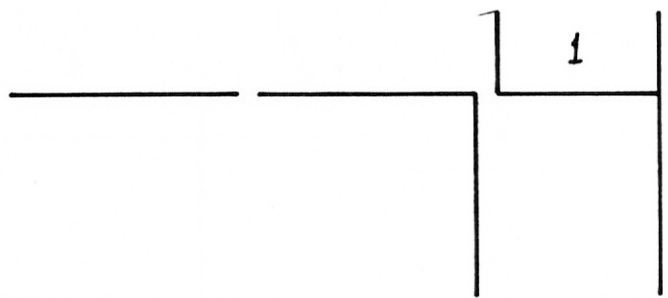

4

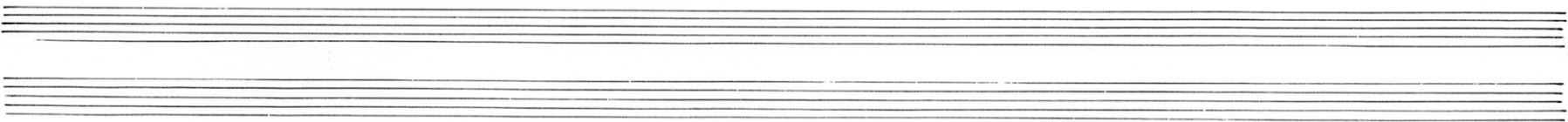

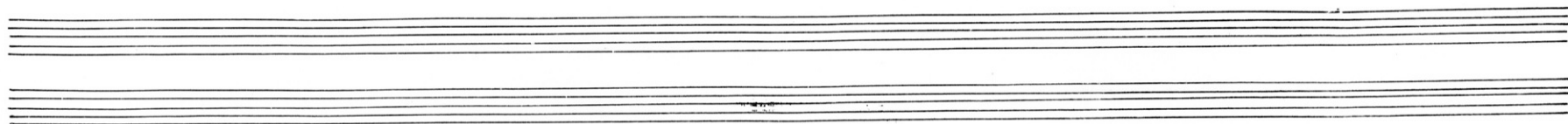
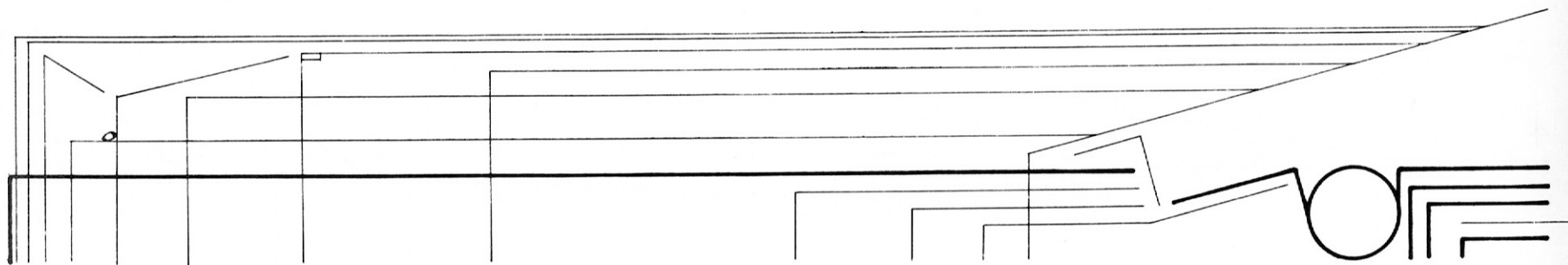

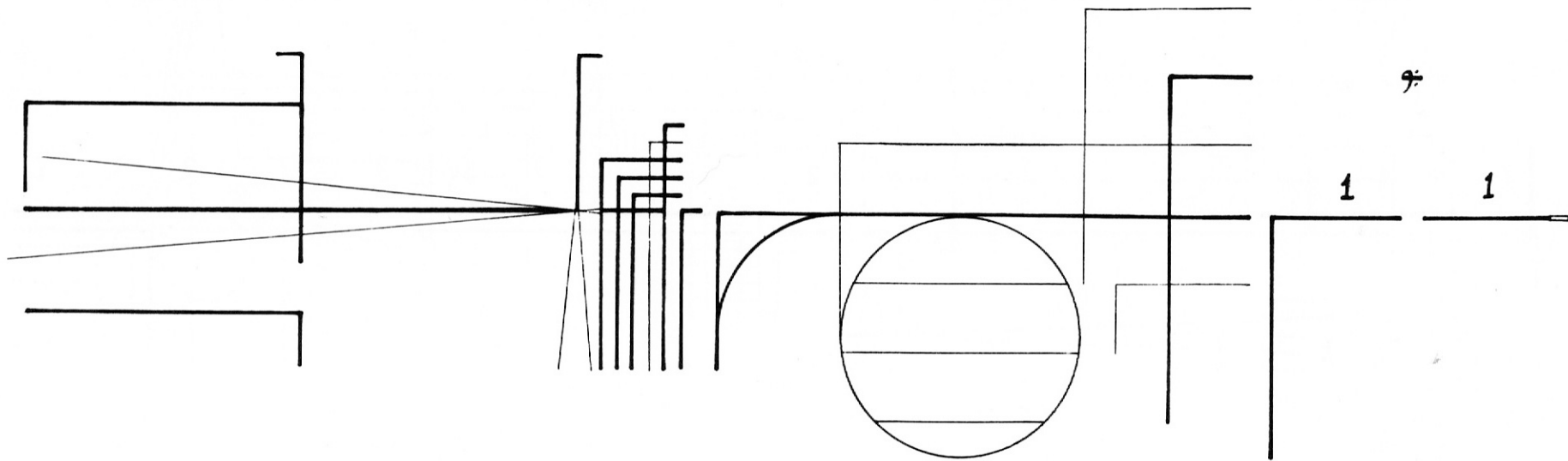

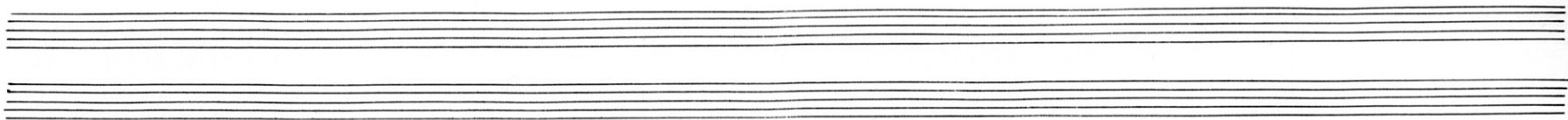
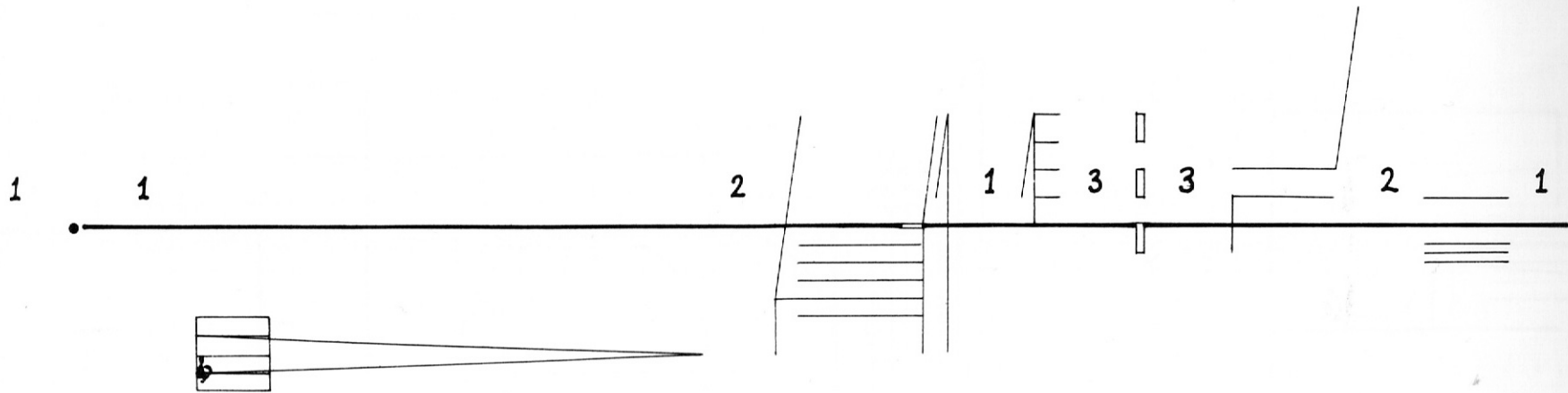

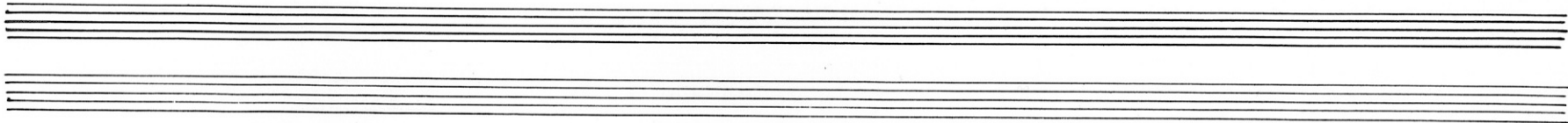
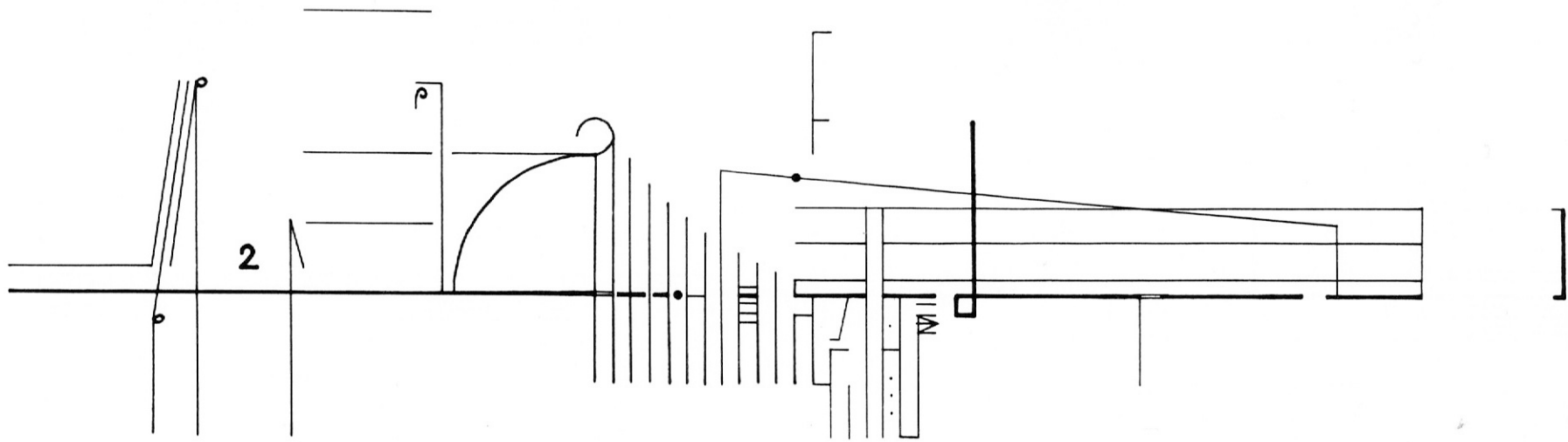

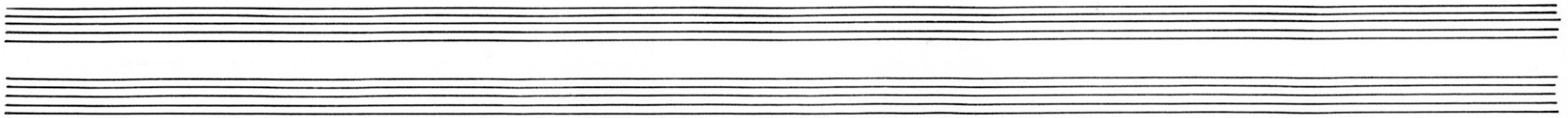
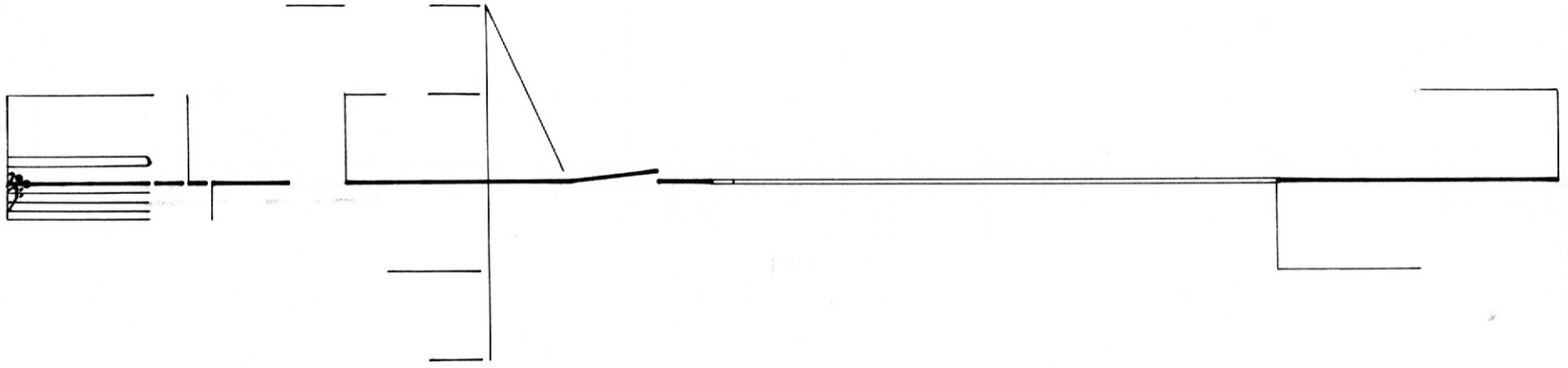

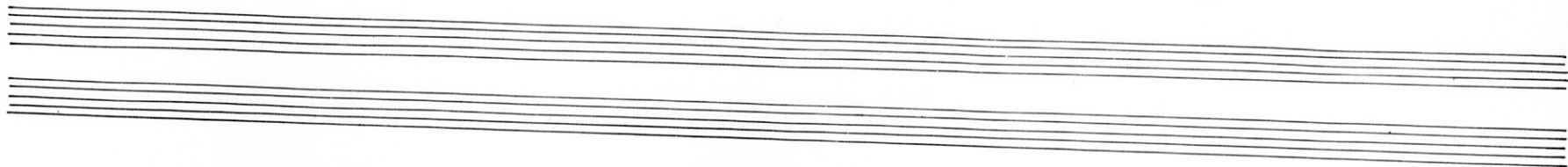
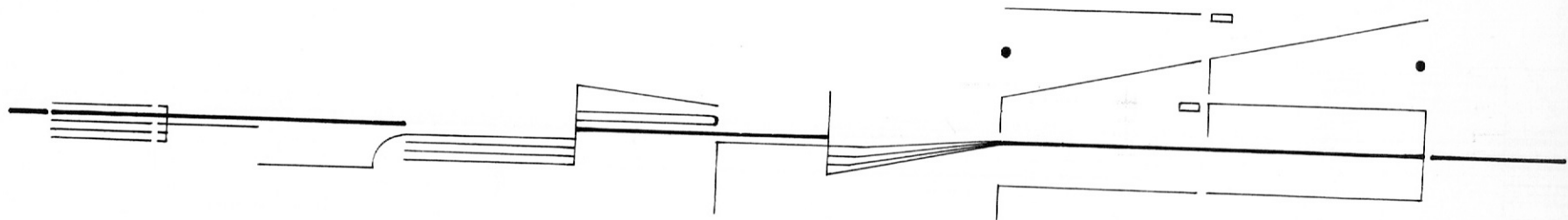

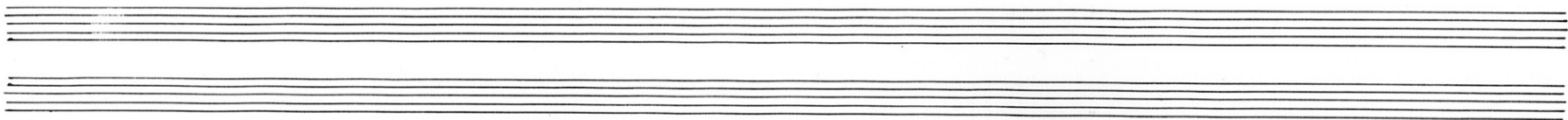
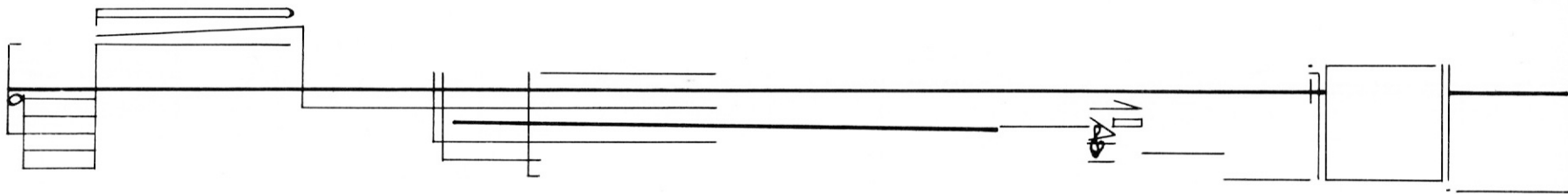

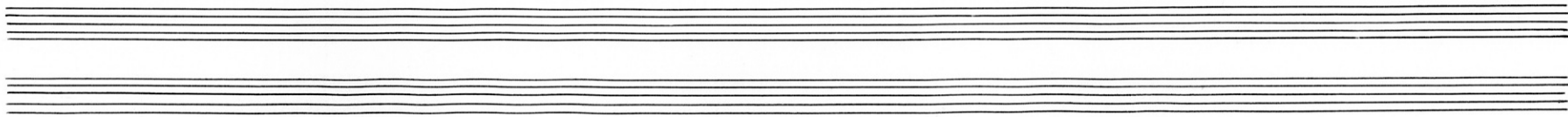
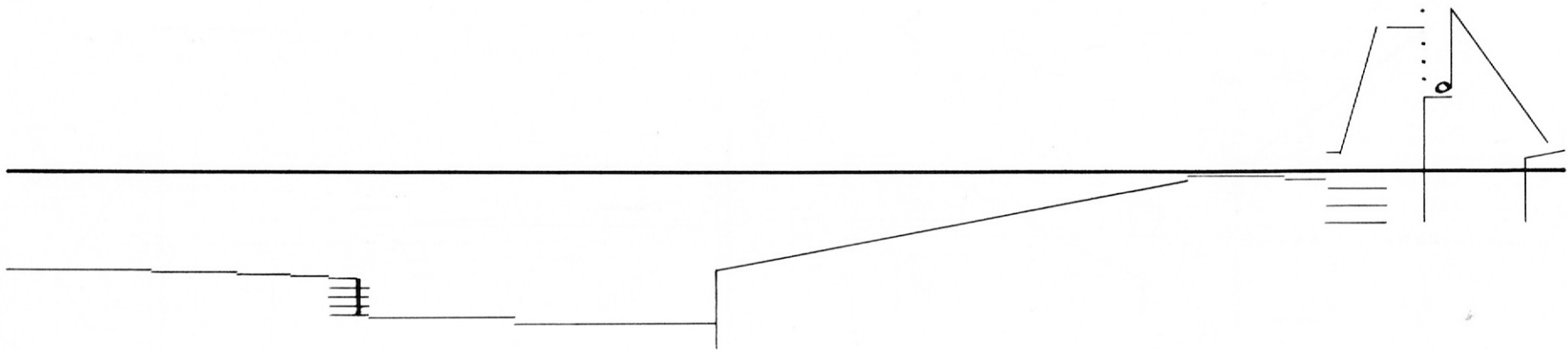

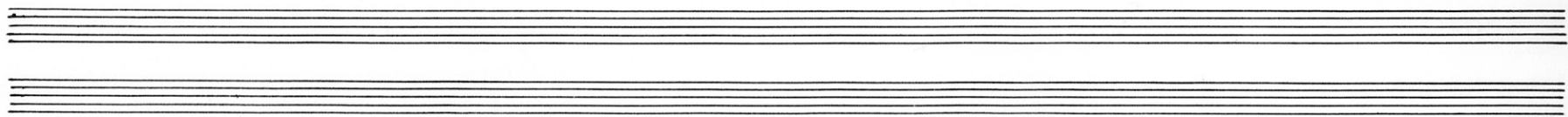
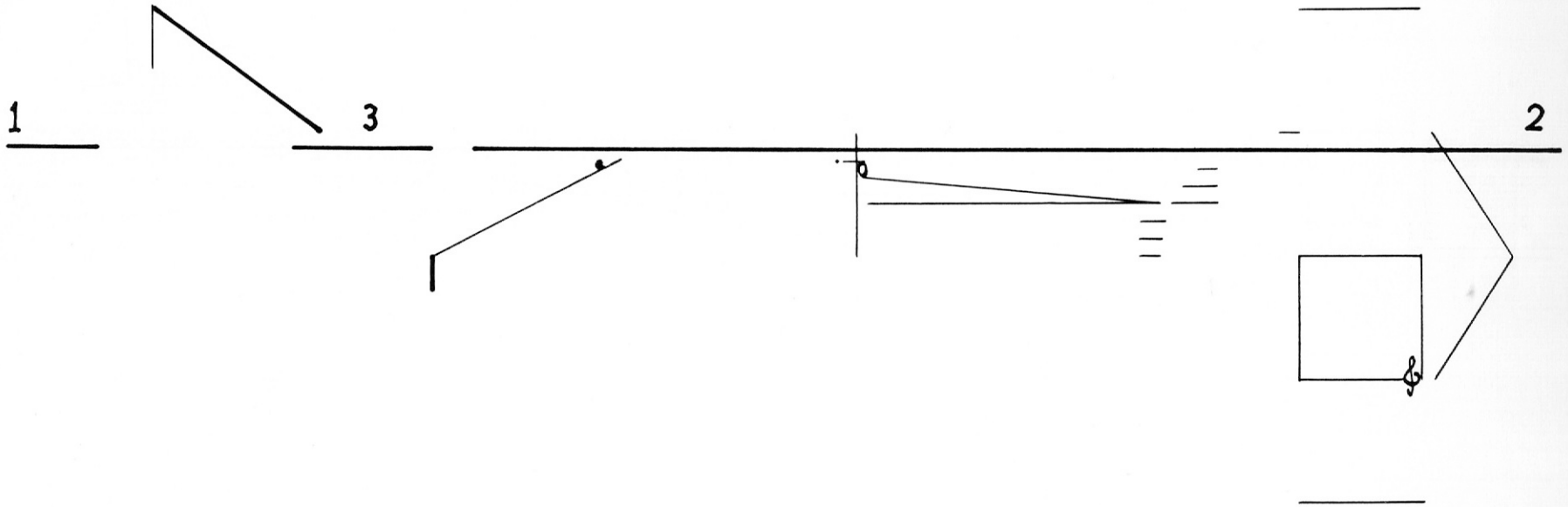

The image shows a handwritten musical score on a page. The score is divided into two systems. The upper system consists of two staves. The first system on the left has a treble clef and a key signature of one flat (B-flat). It contains several measures of music, including a double bar line. The second system on the right has a treble clef and a key signature of one flat. It contains several measures of music, including a double bar line and a fermata. There are some handwritten annotations, such as a 'p' (piano) dynamic marking and a 'b.' (breath mark) above a staff. The lower system consists of two empty staves.

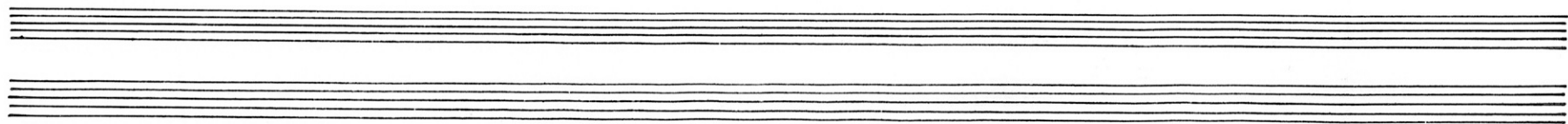
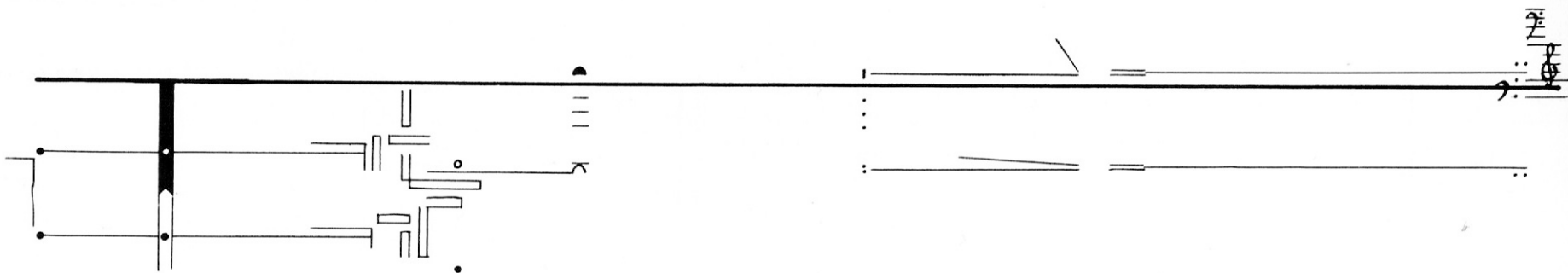

Handwritten musical notation on a staff. The notation includes a treble clef, a bass clef, and a bass clef with a flat symbol (b). There are several notes, some with stems, and dynamic markings such as *pp*. A large, tilted rectangular box is drawn over the staff, containing a bass clef and some horizontal lines. To the right of the staff, there are several horizontal lines with dots and stems, resembling a simplified musical staff or a diagram. The overall appearance is that of a sketch or a conceptual drawing related to music.

Two sets of empty musical staves, each consisting of five horizontal lines. They are positioned at the bottom of the page, below the main musical notation.

&

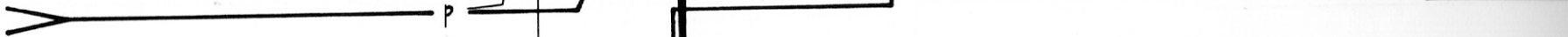
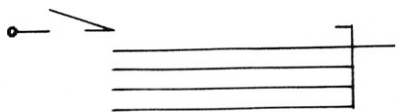

7

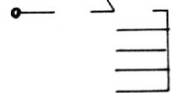

p



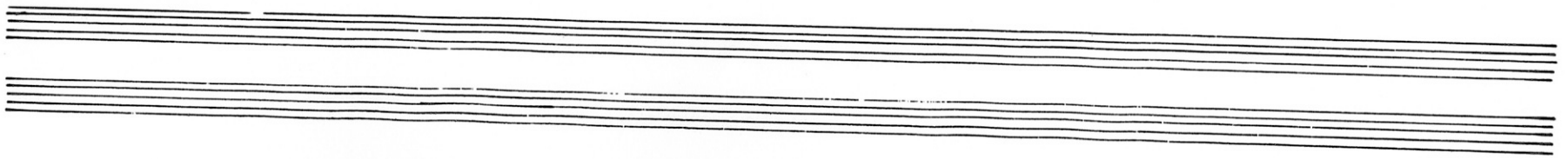
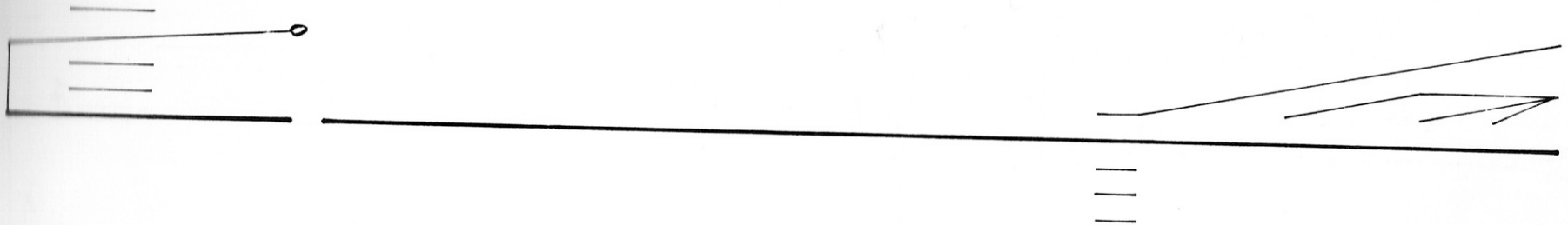

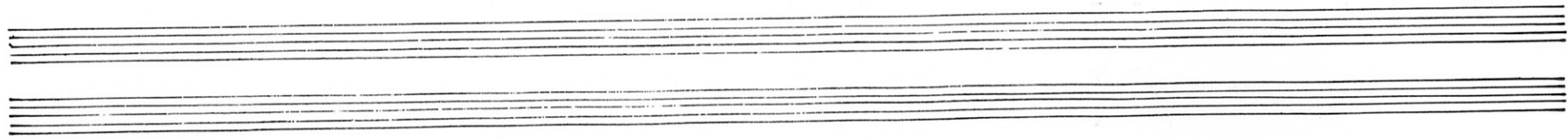
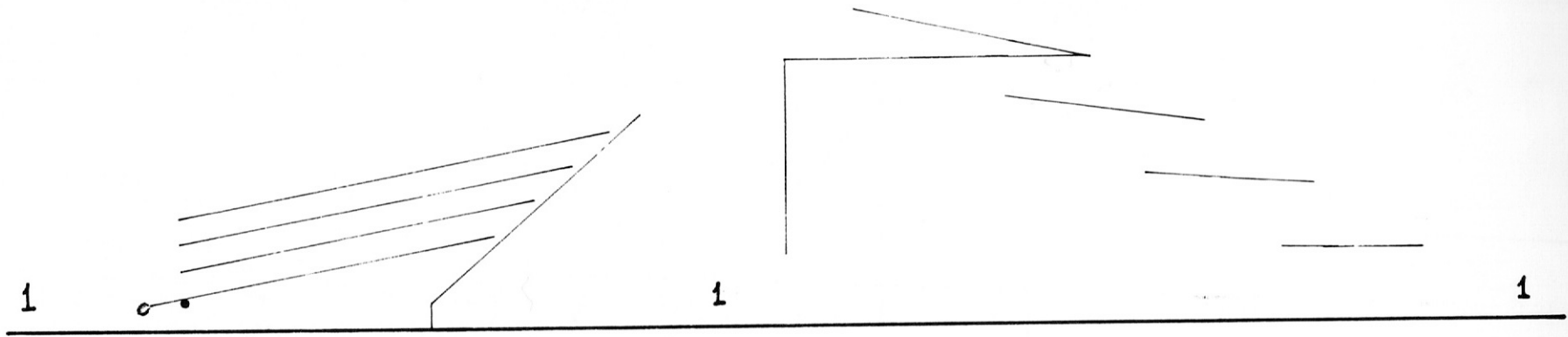

-



-

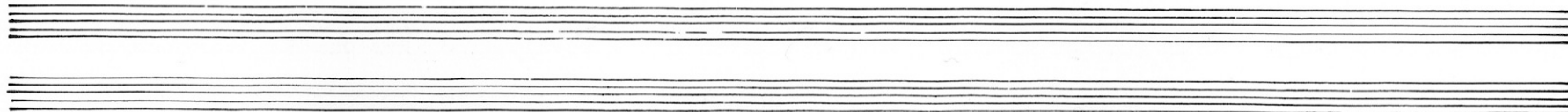

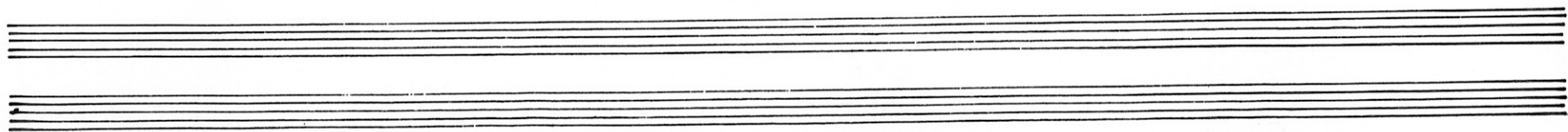
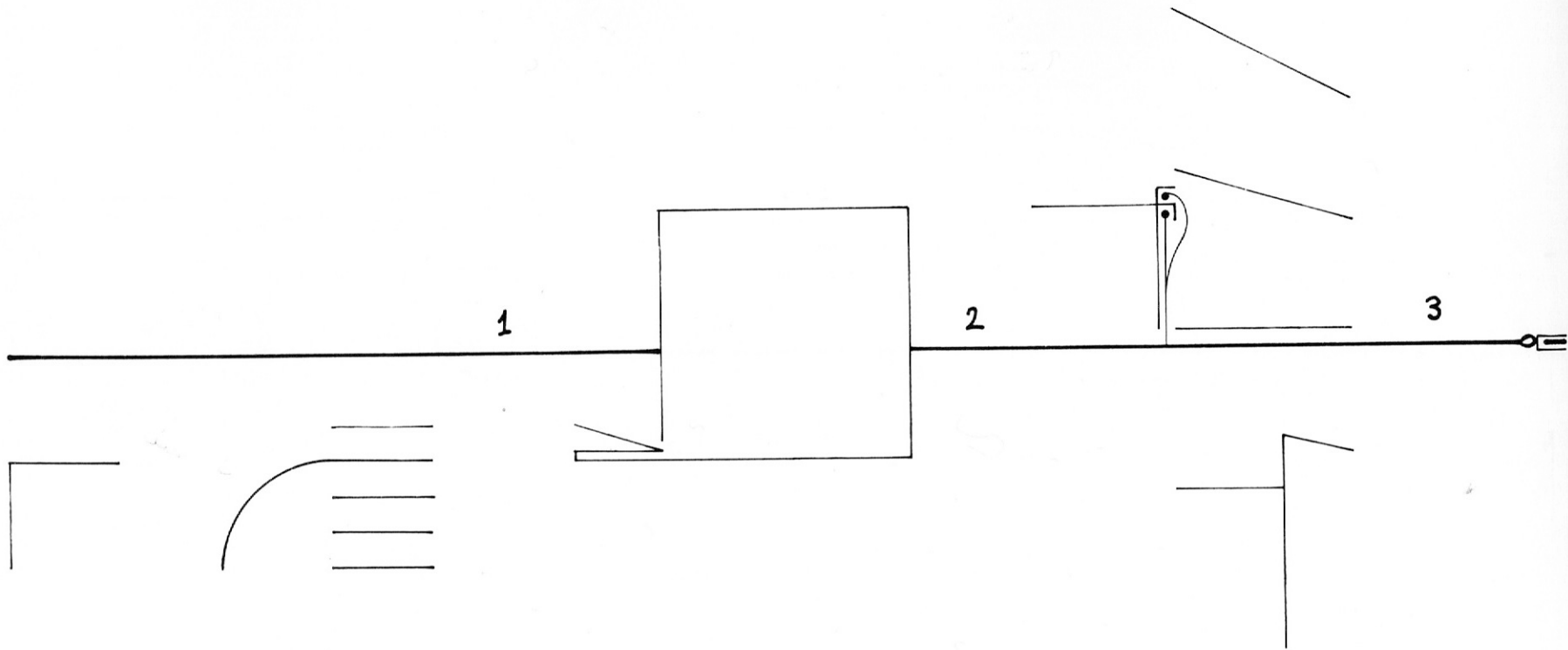

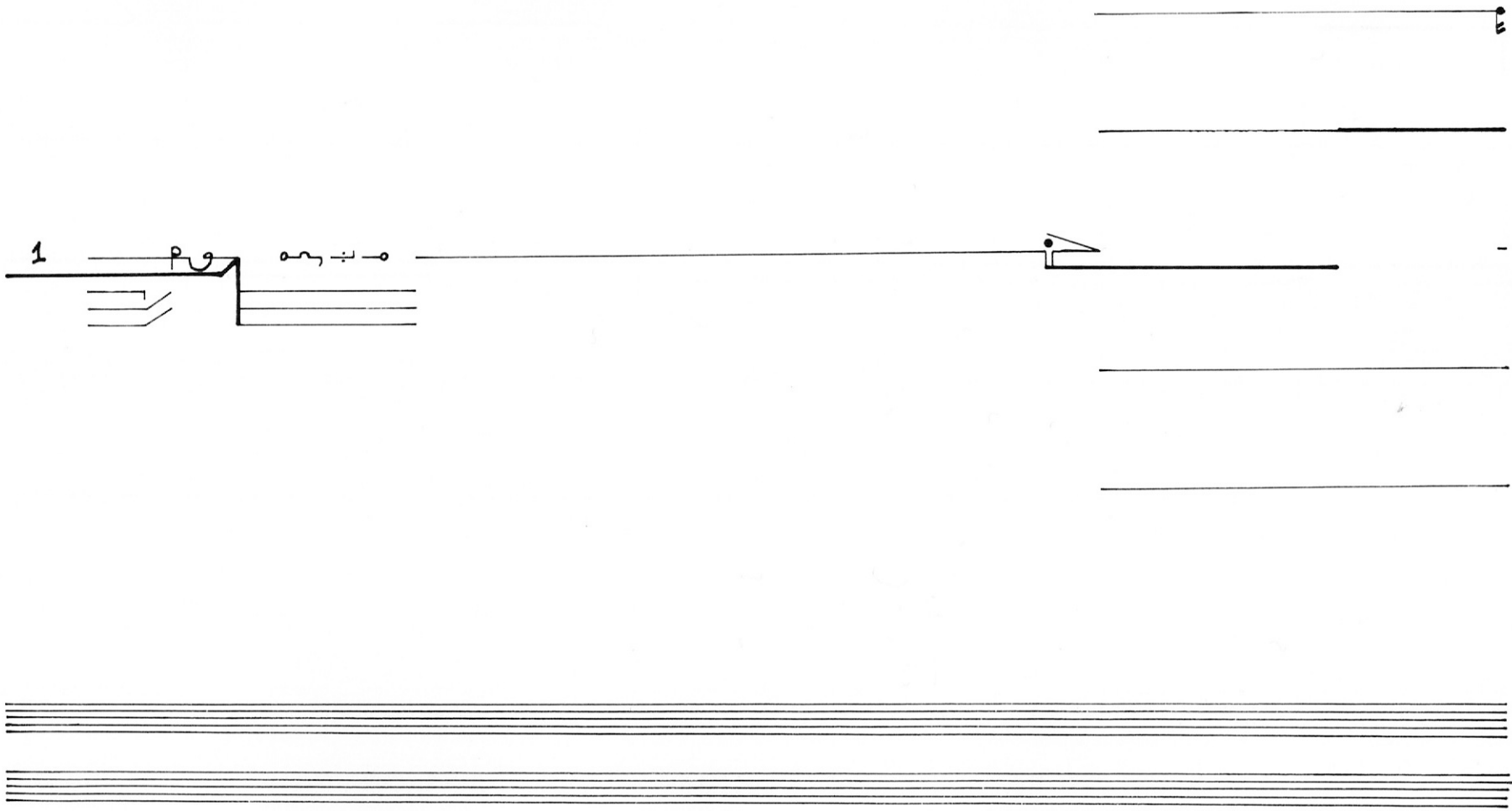

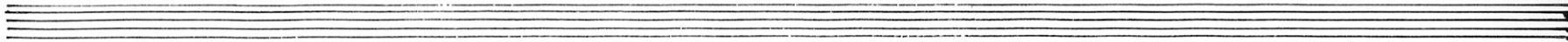
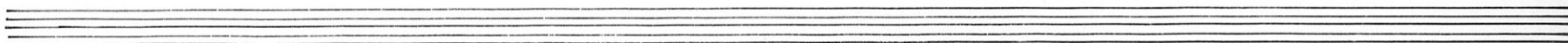
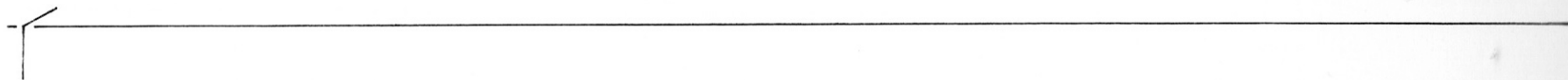
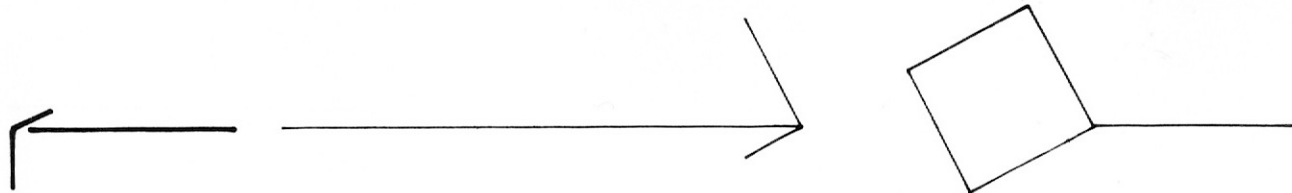

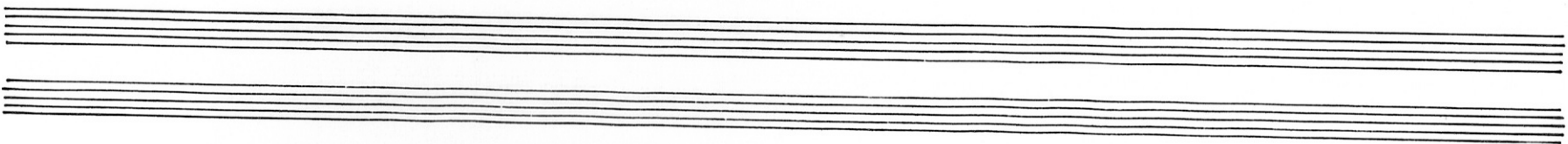
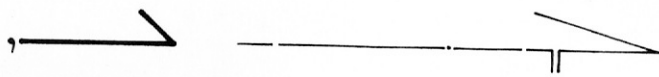

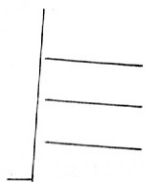

1

2

1

.

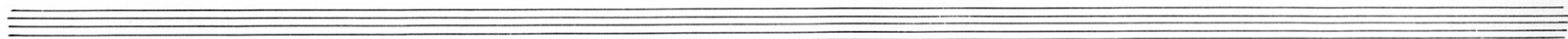
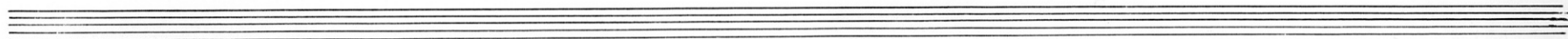

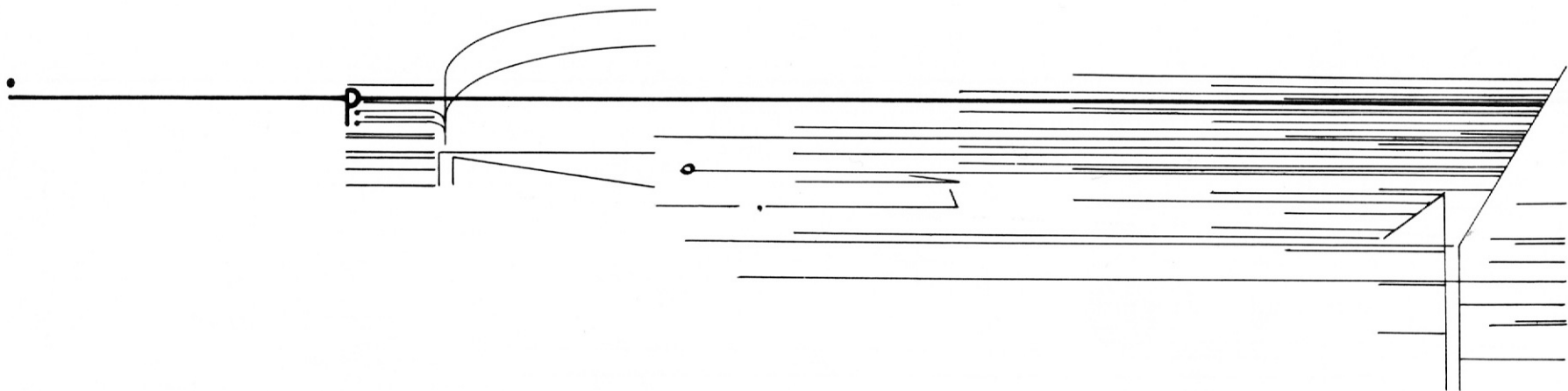

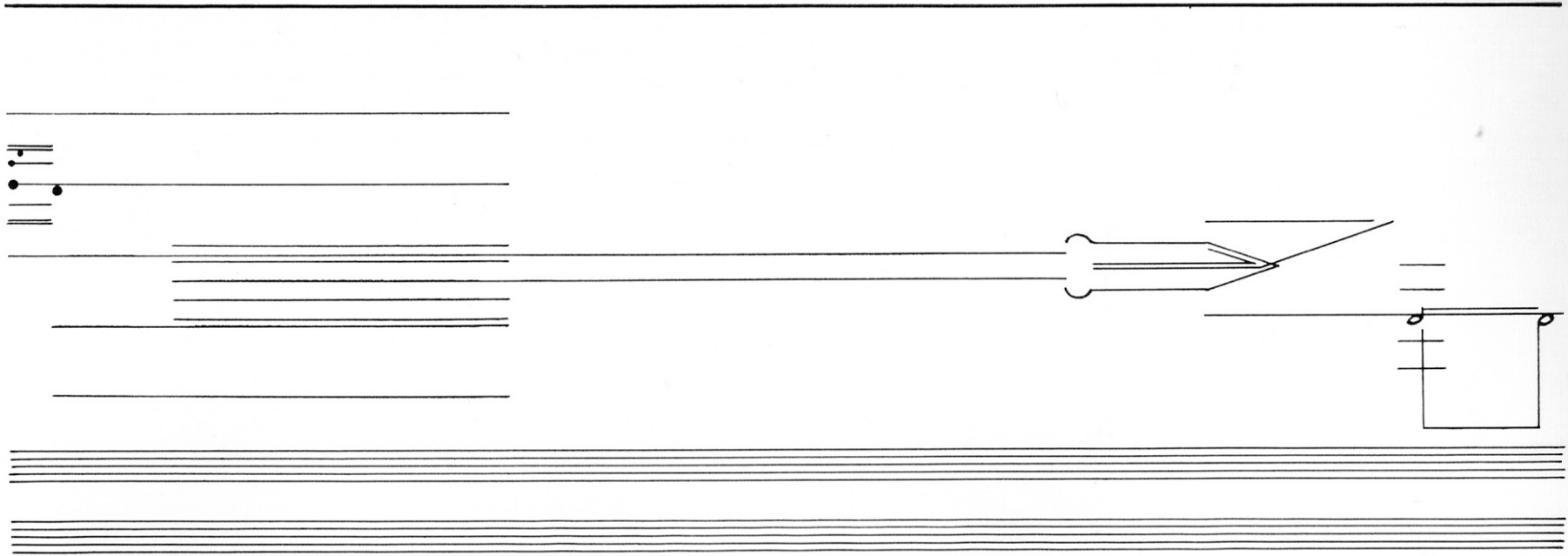

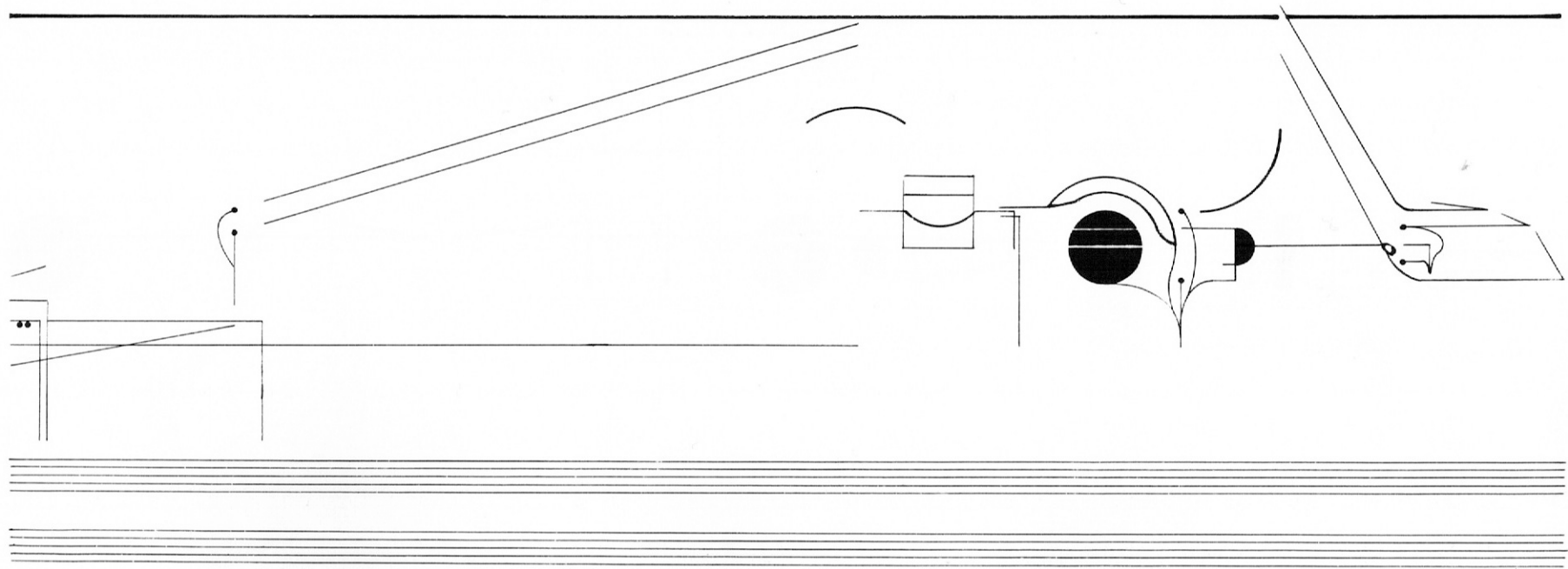

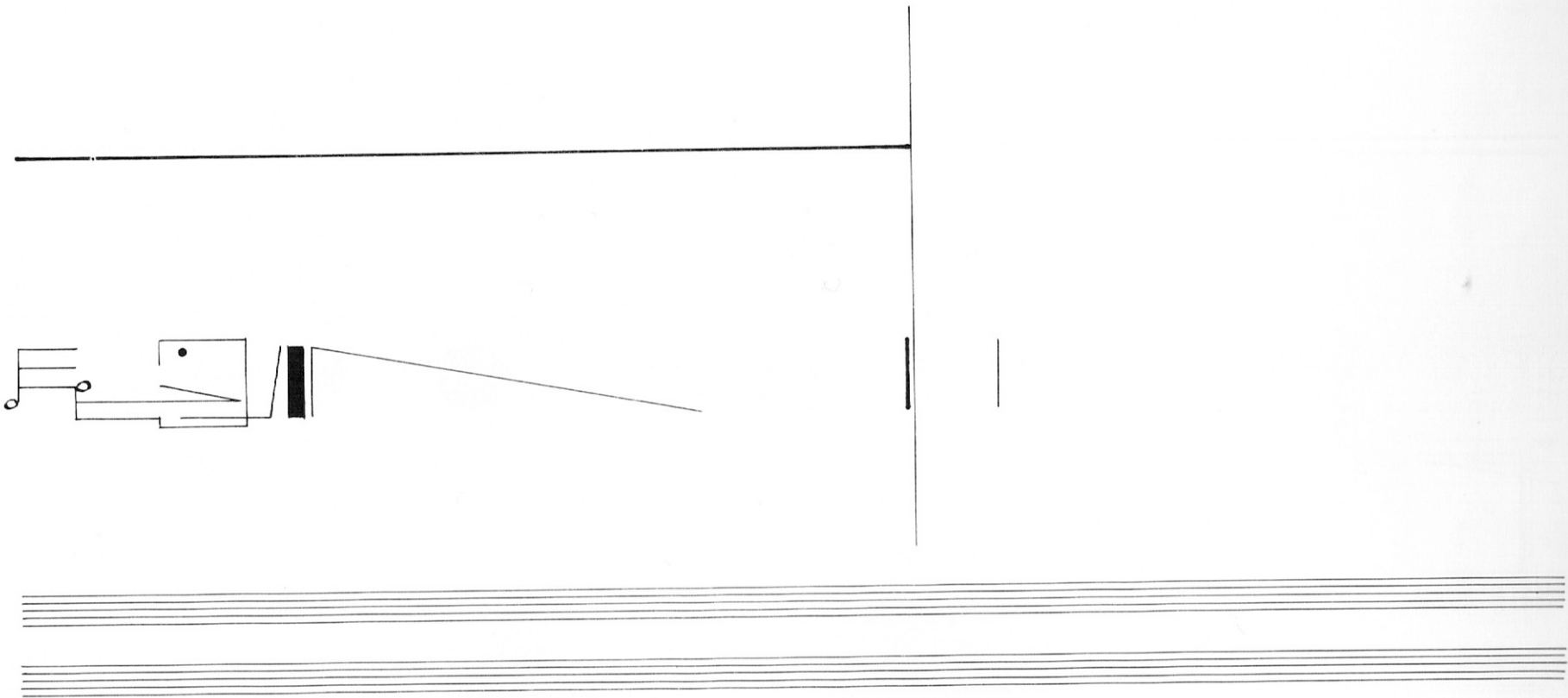

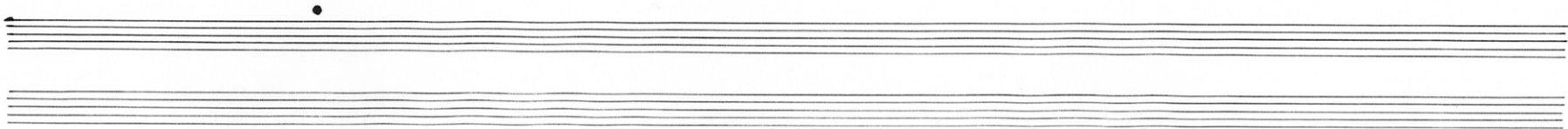
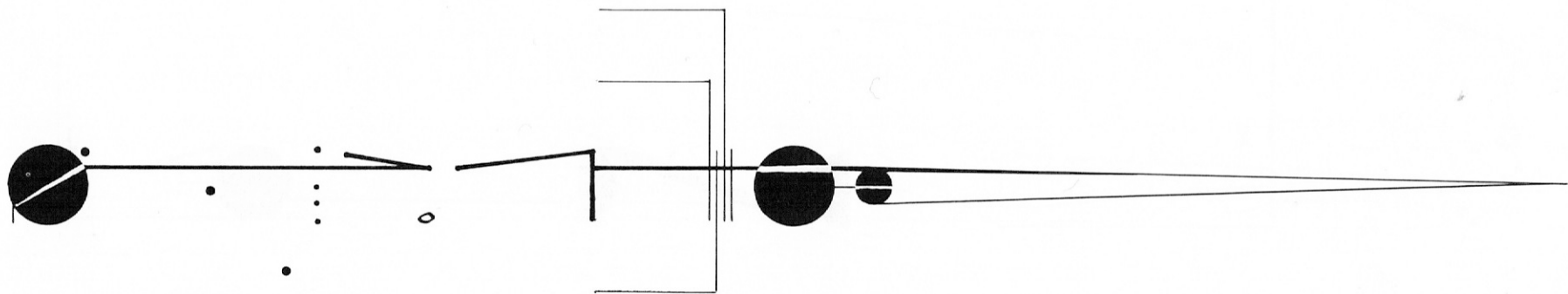

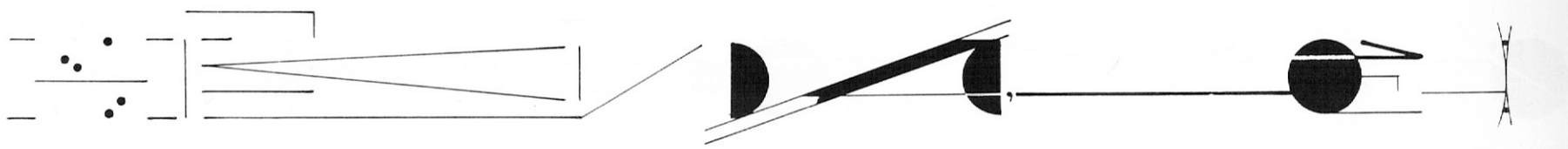

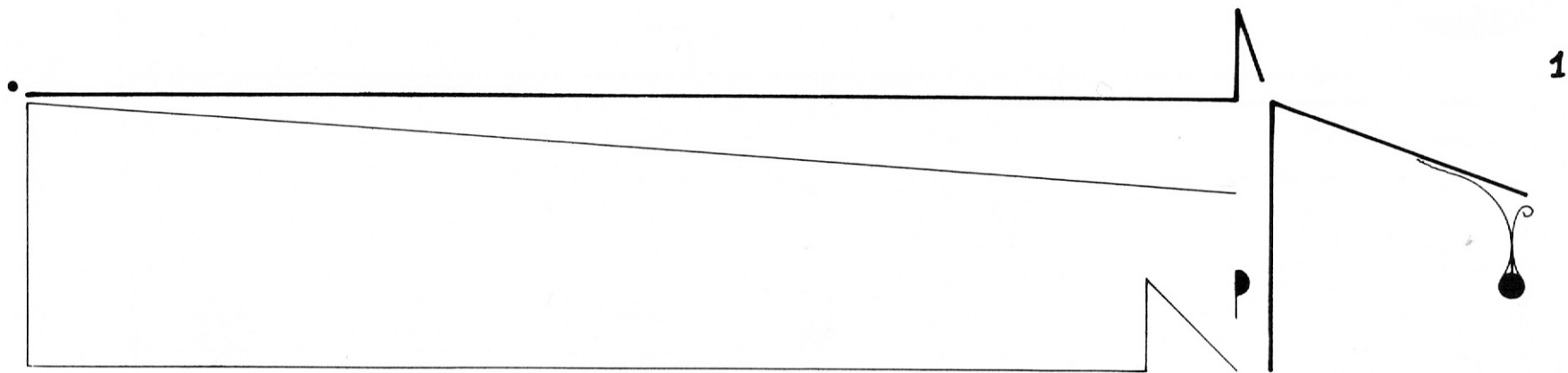

1



A handwriting practice sheet featuring a central horizontal line. Above the line, there is a circle with a dot above it and a '1' below it. To the right of the circle are two horizontal dashes. Below the line, there is a zigzag line with a square at its base, followed by a 'b' with a dot above it and a '1' below it. To the right of this is a 'be' with a diagonal line above it and two horizontal dashes. At the bottom of the page, there are two sets of four horizontal lines, resembling musical staves. A vertical line on the right side of the page is labeled with a '1' at the top.

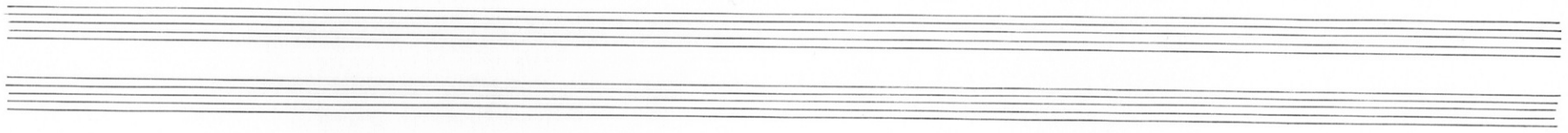
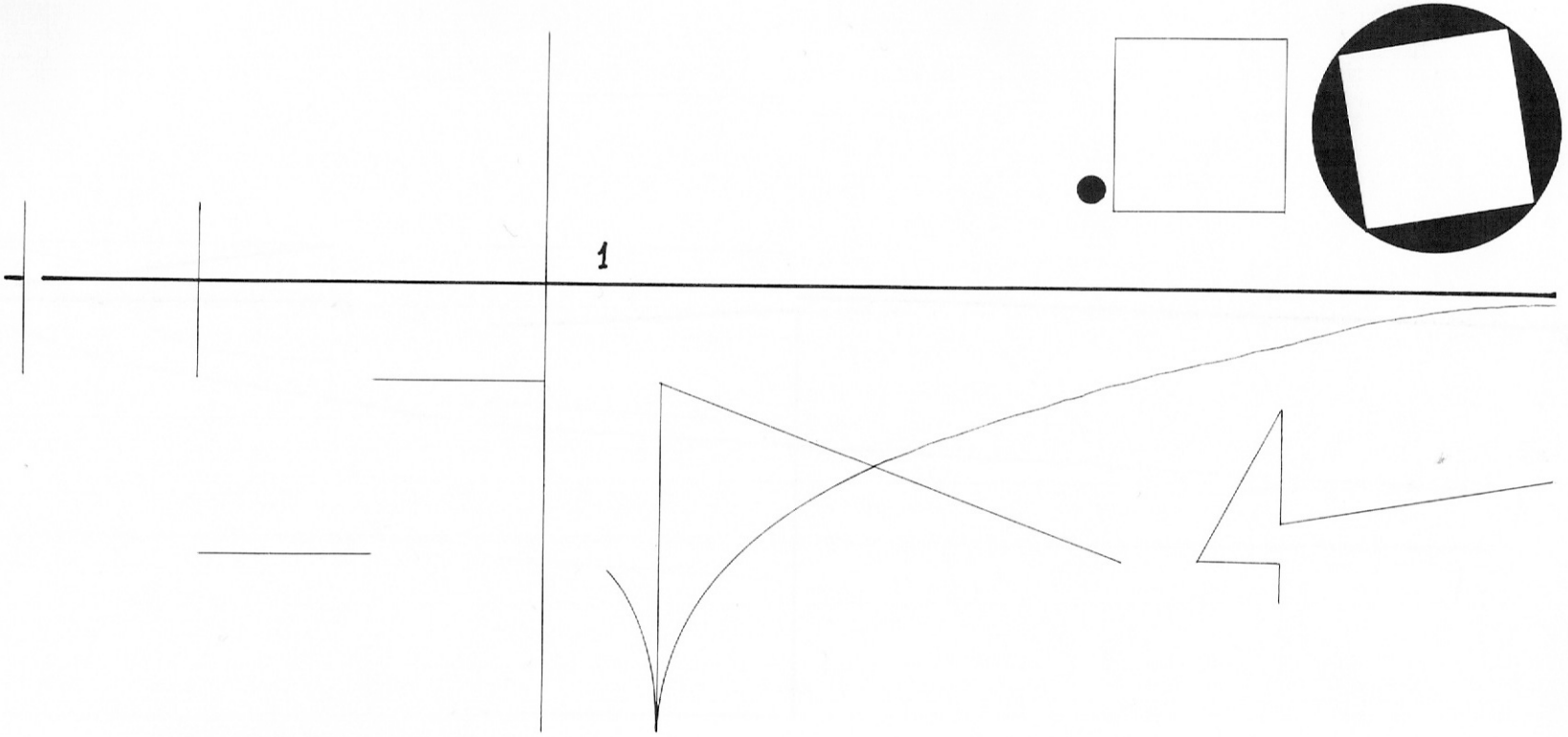

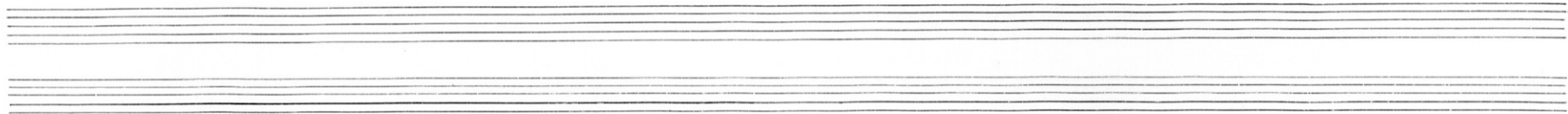
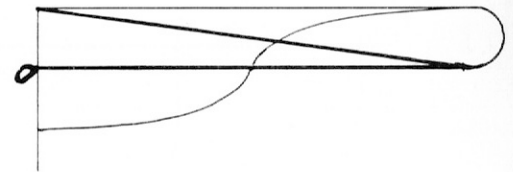
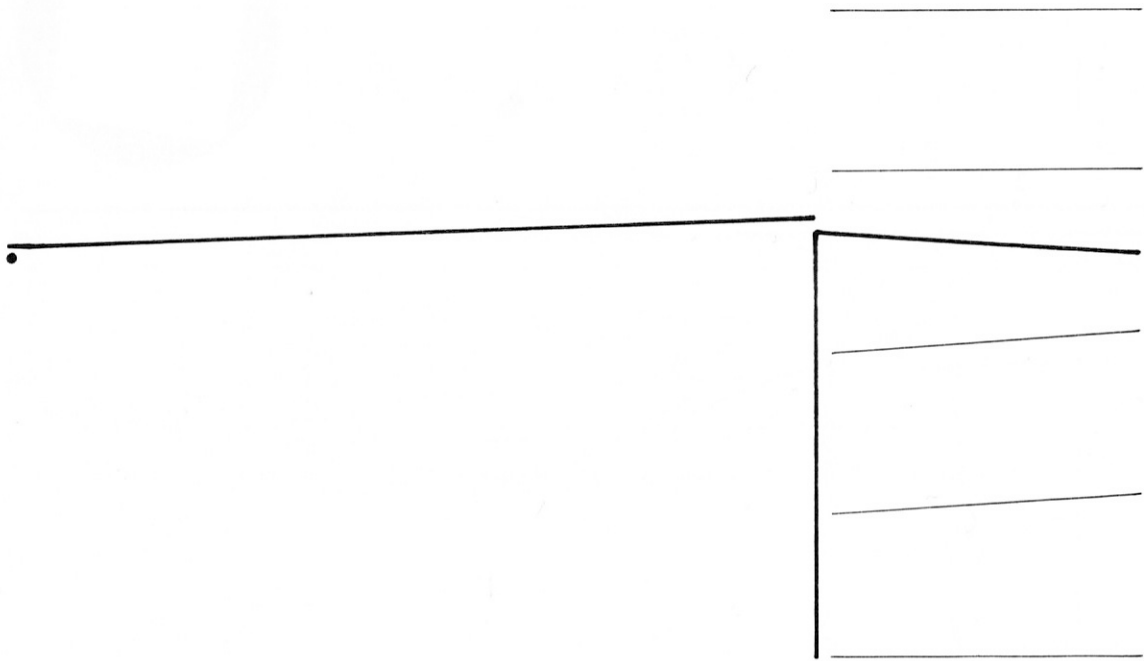

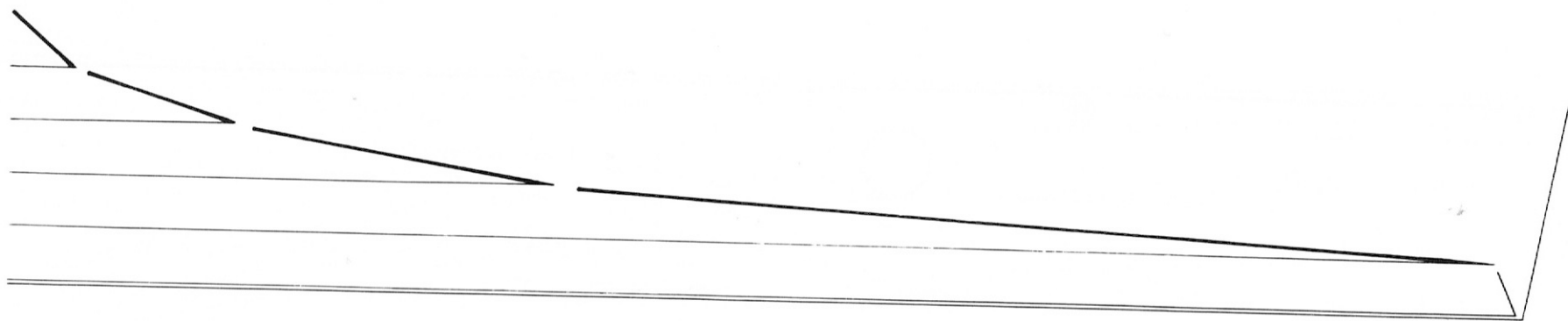

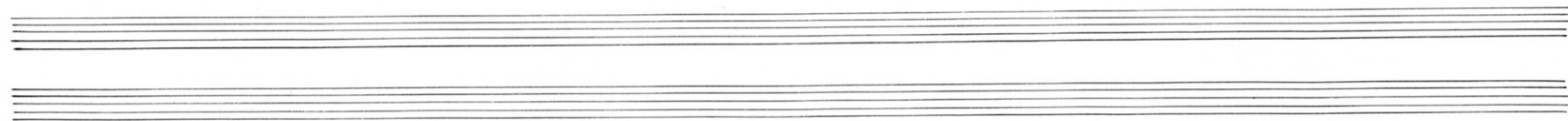
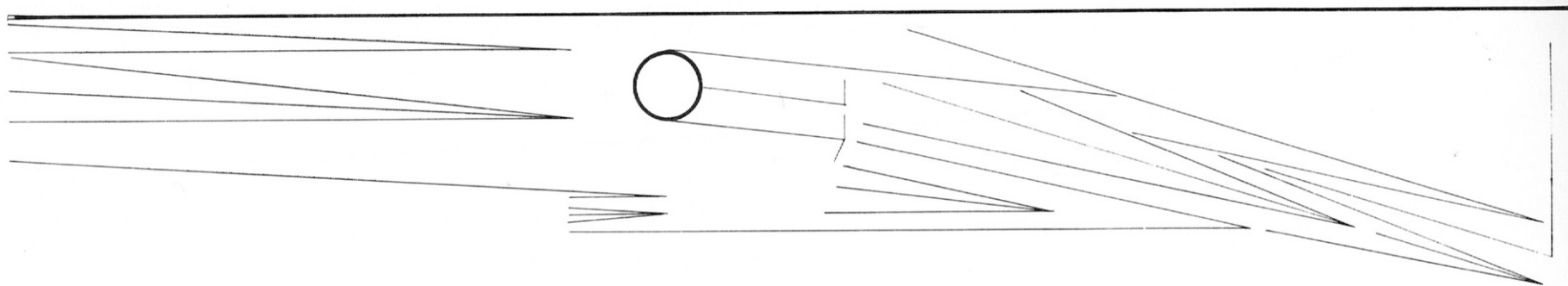

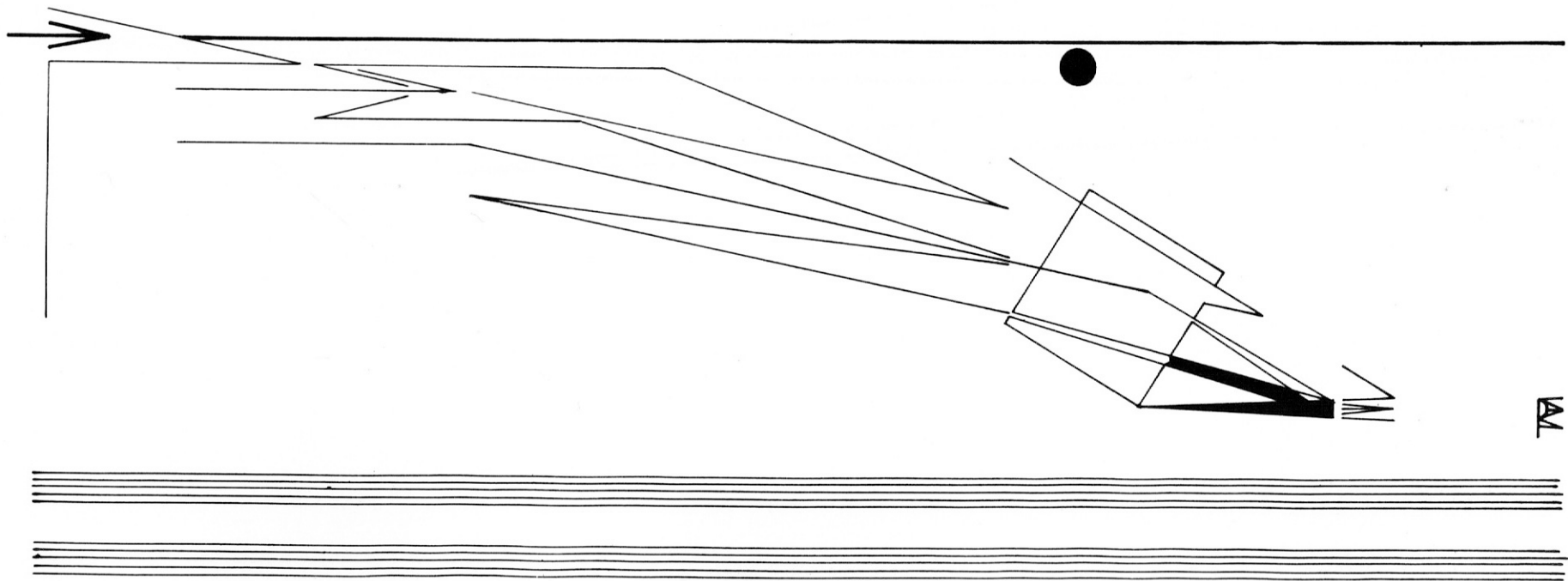

AL

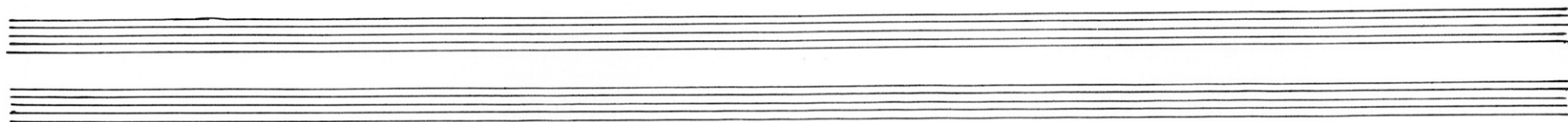
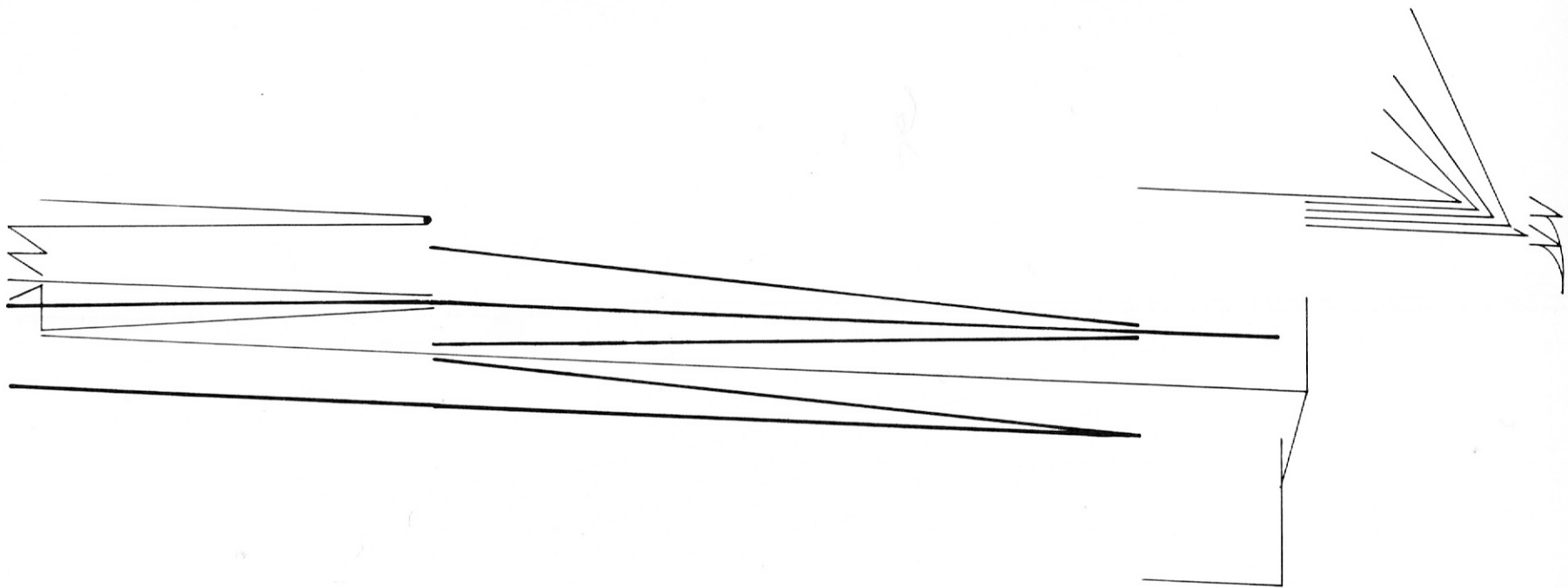

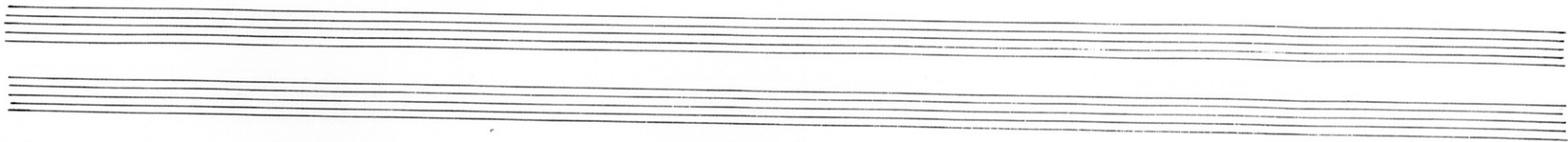
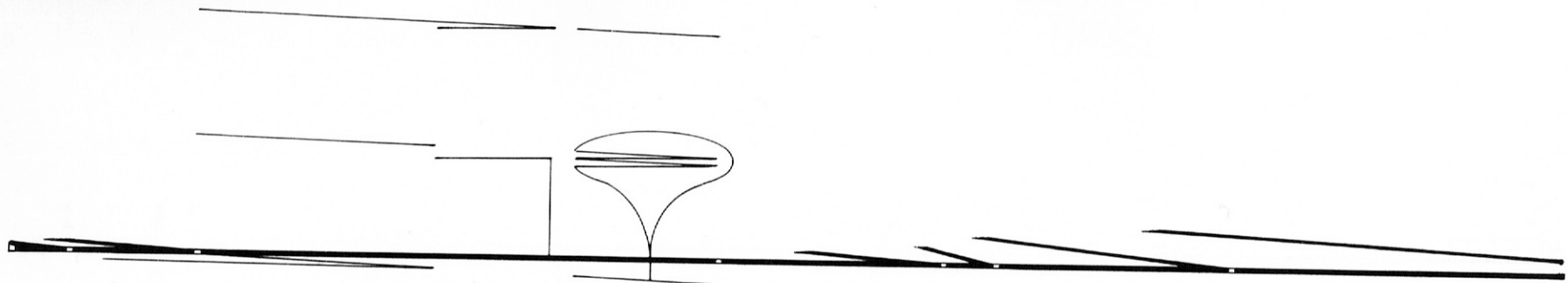

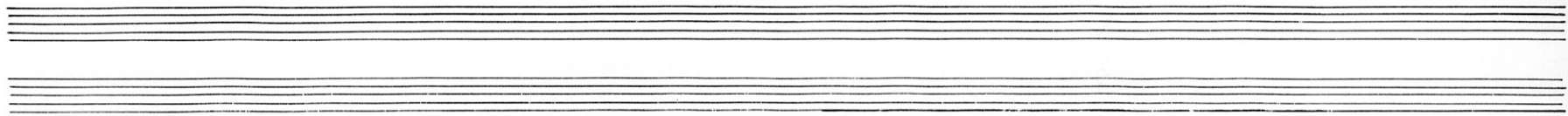
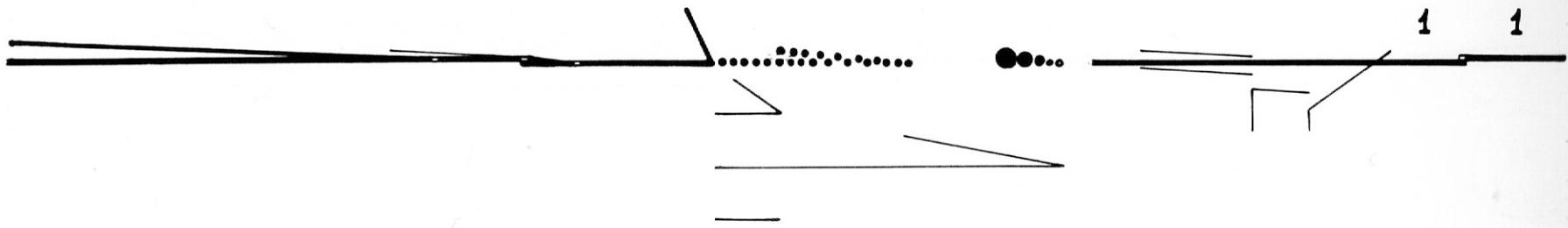

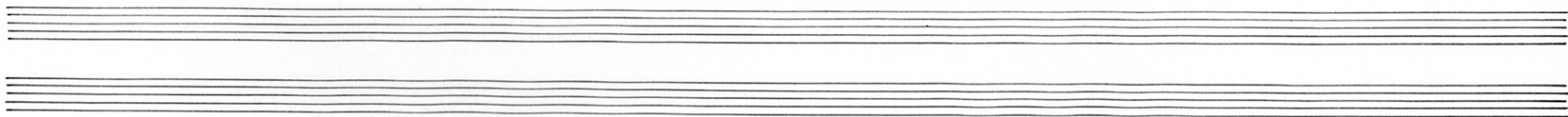
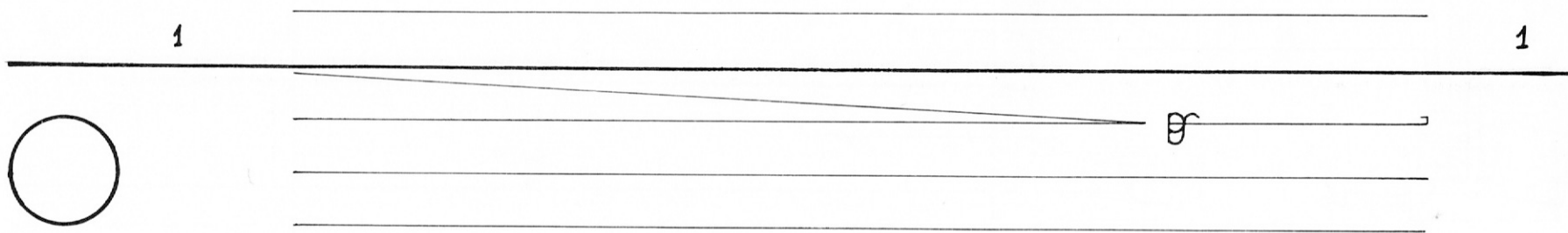

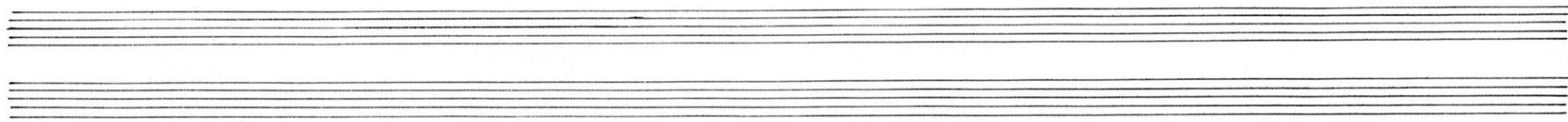
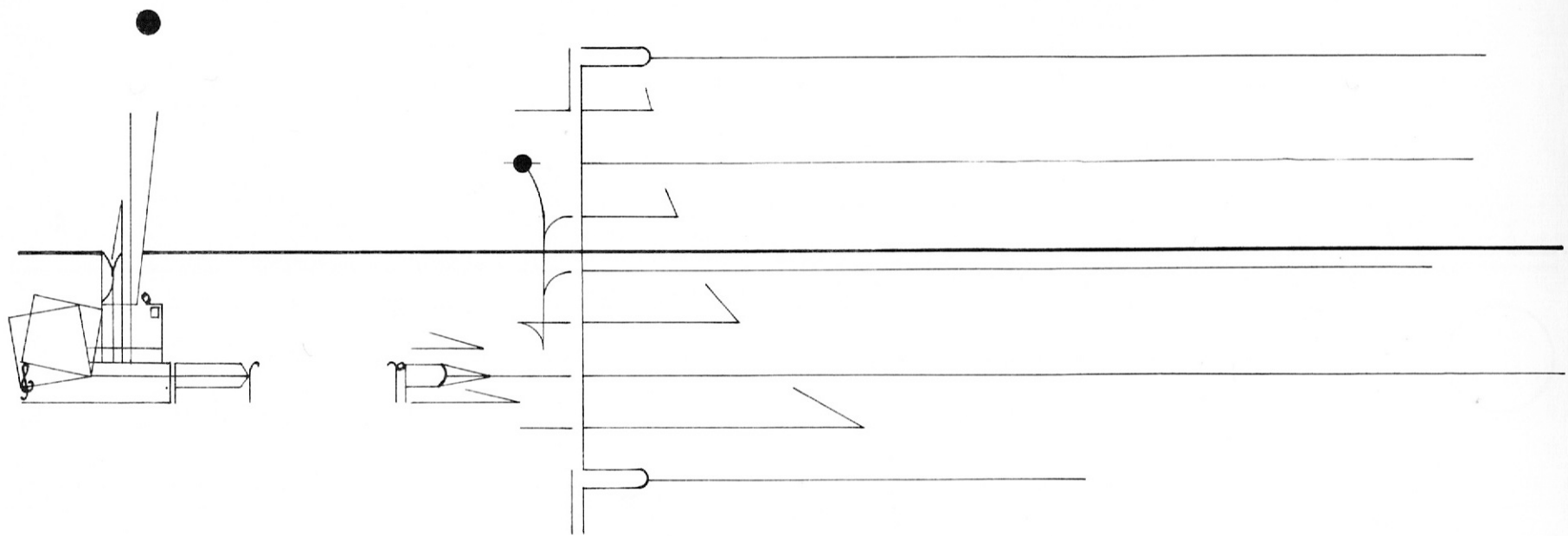

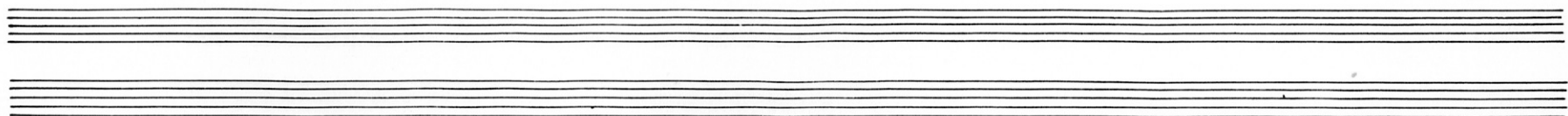
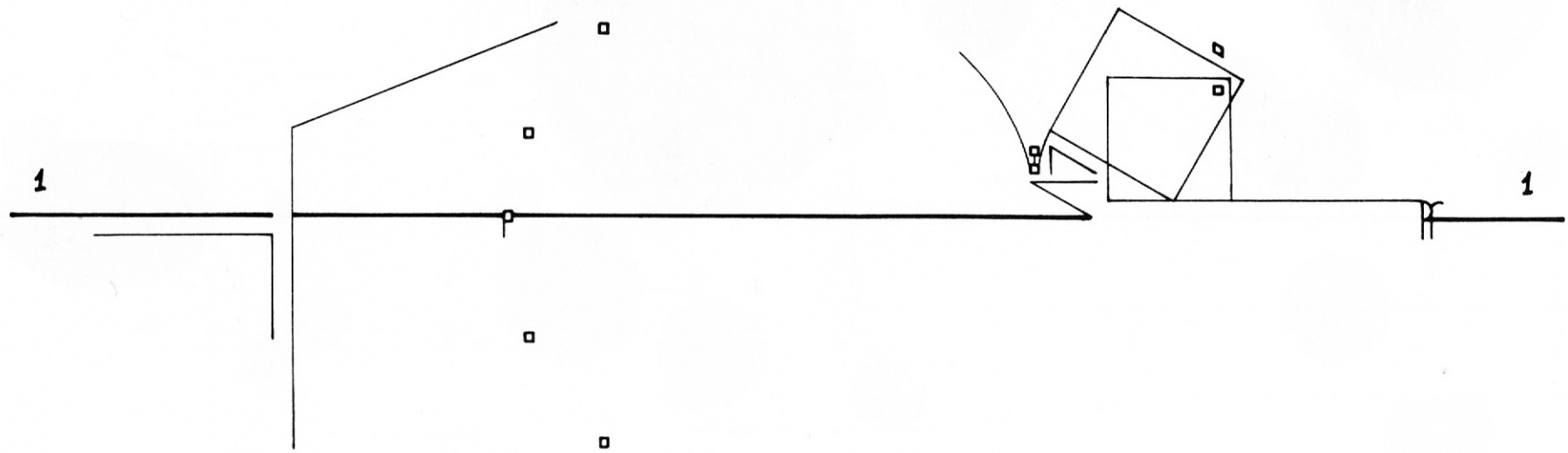

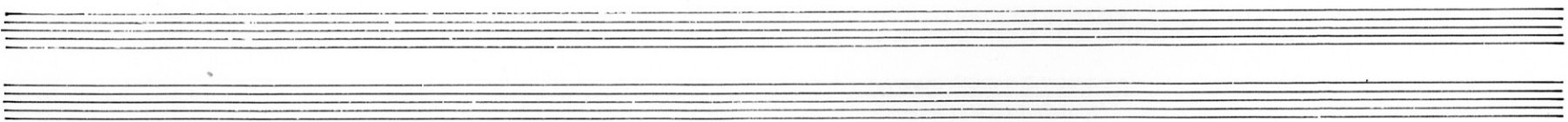
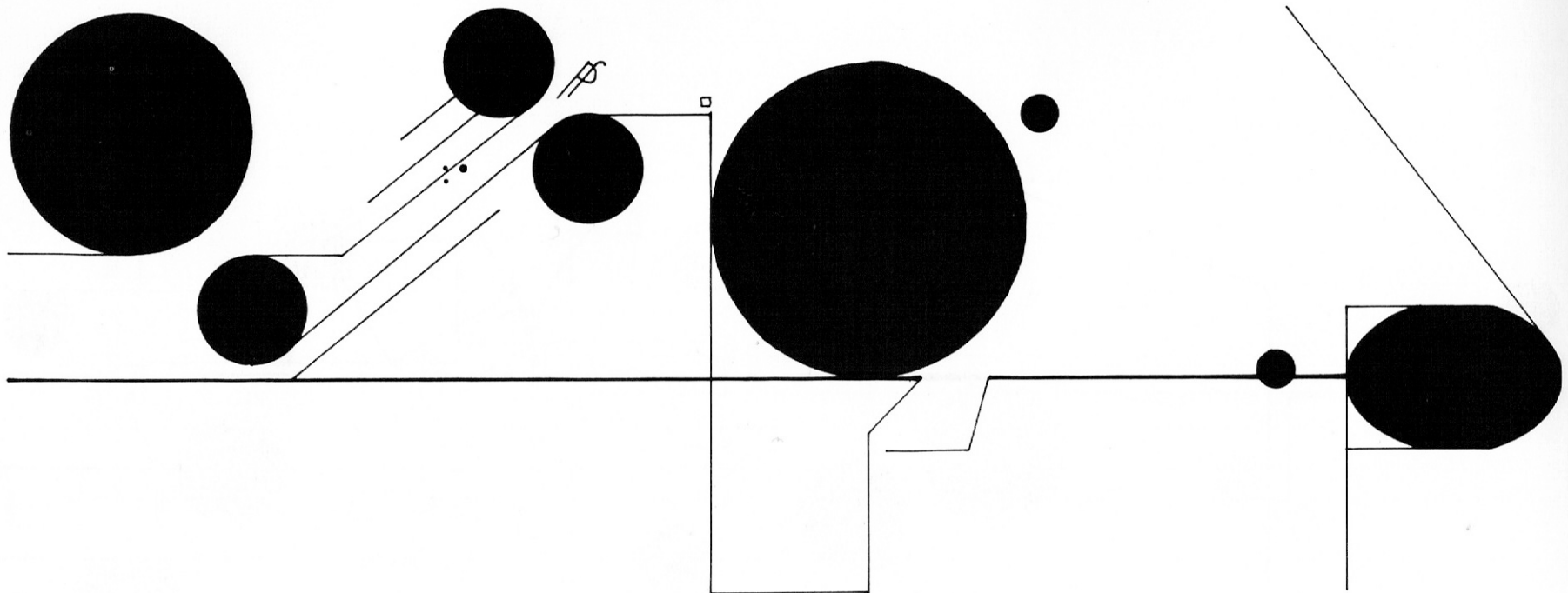

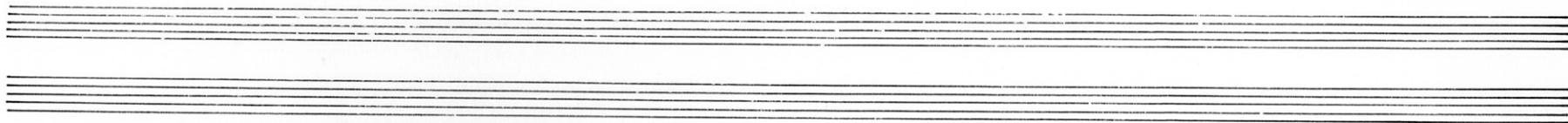
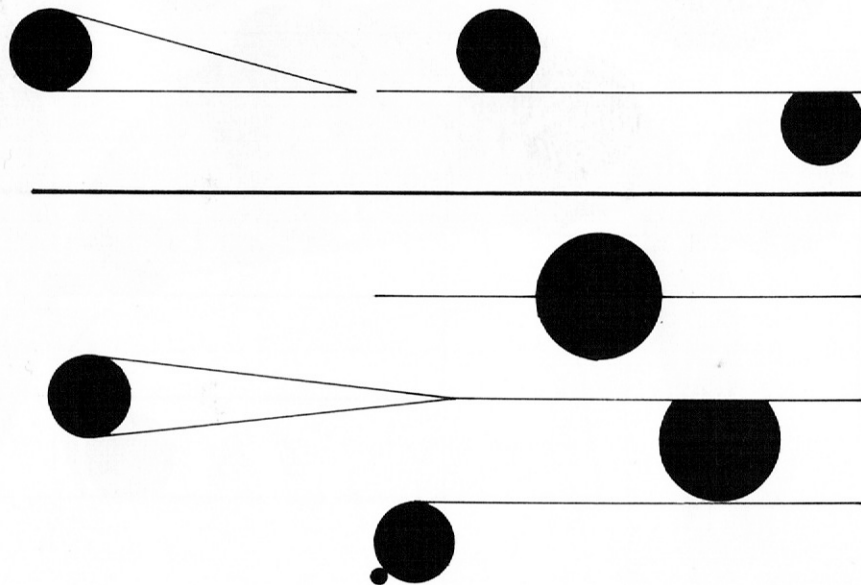
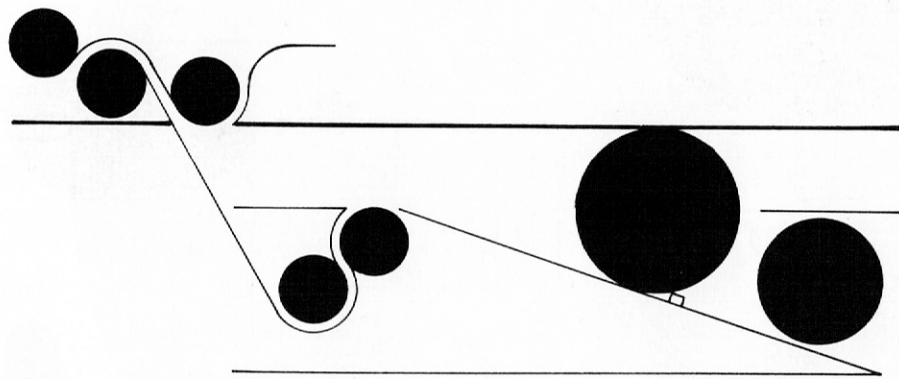

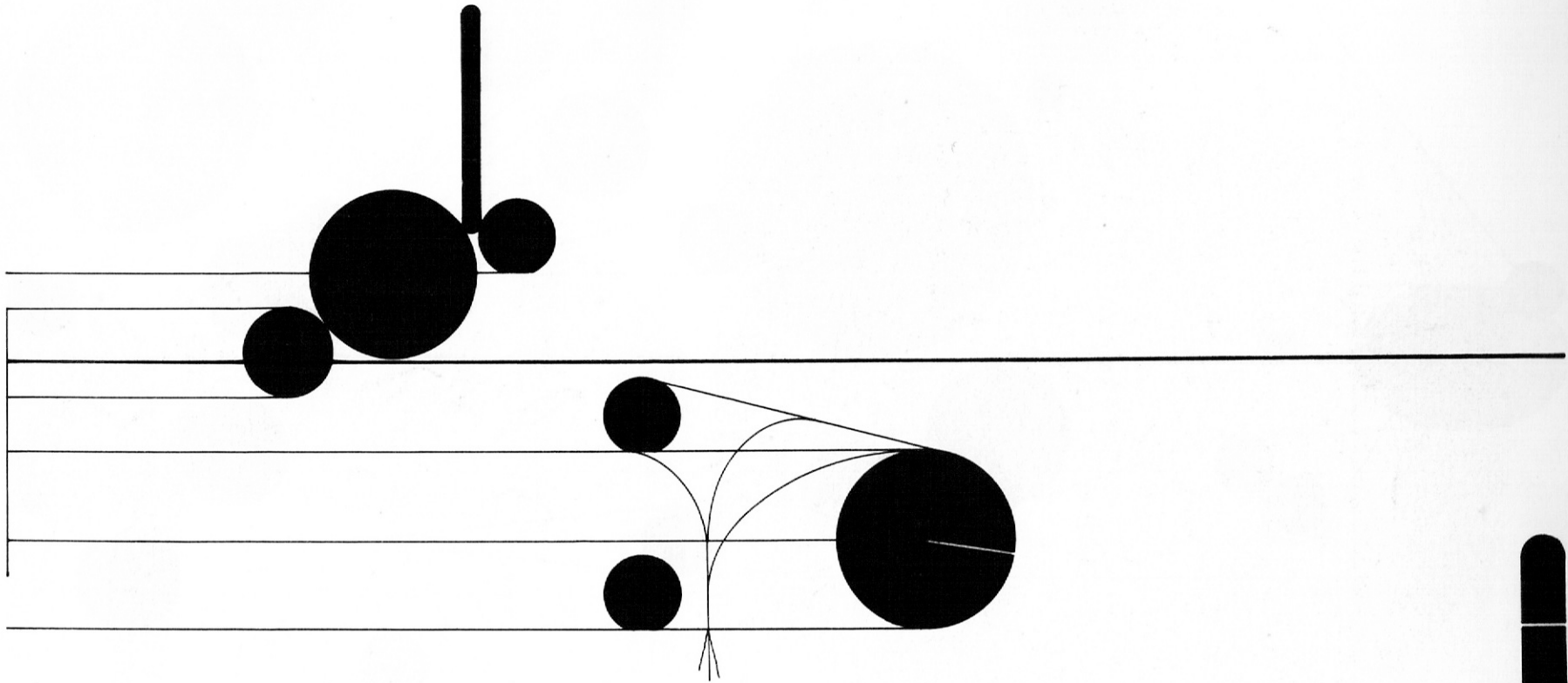

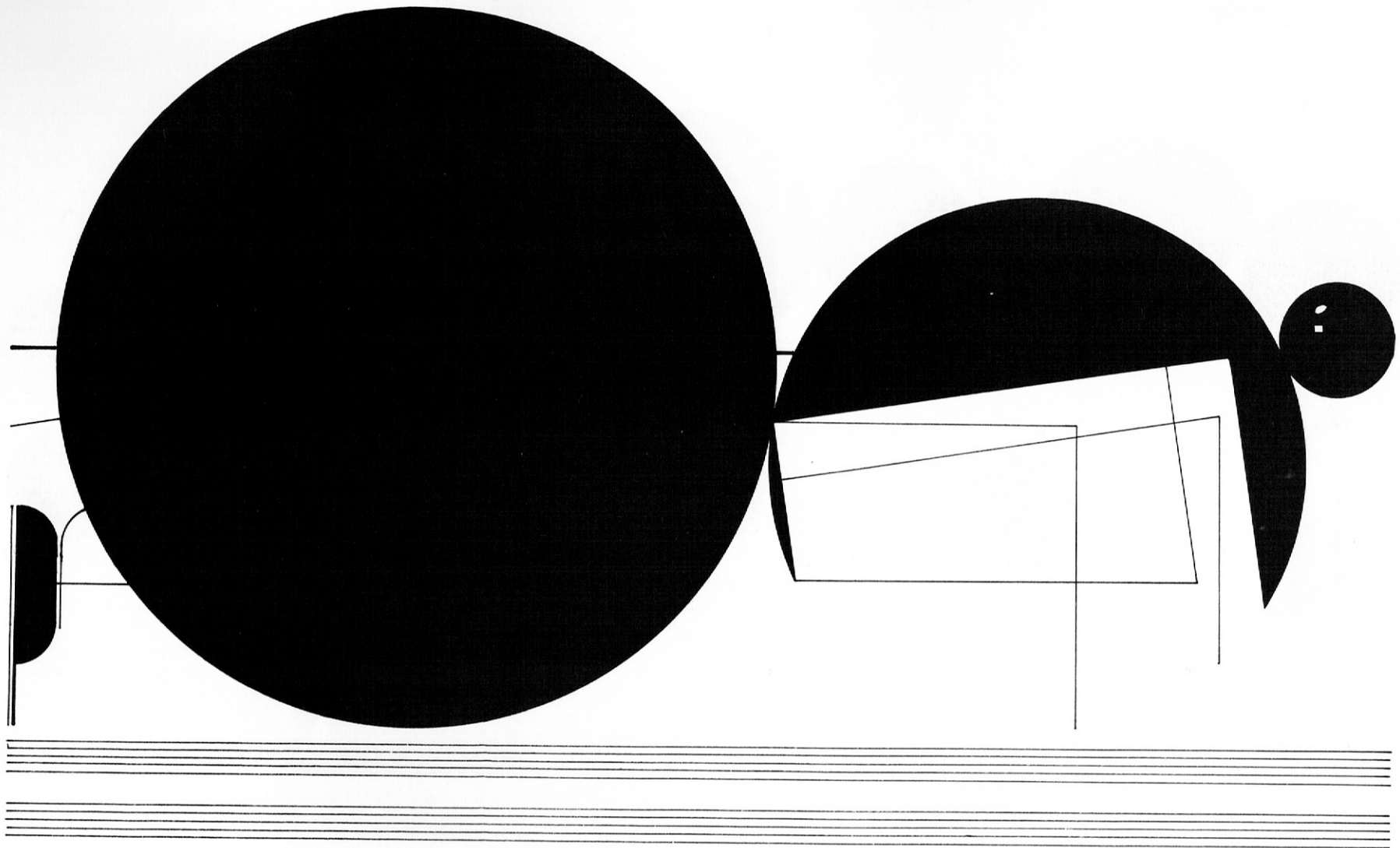

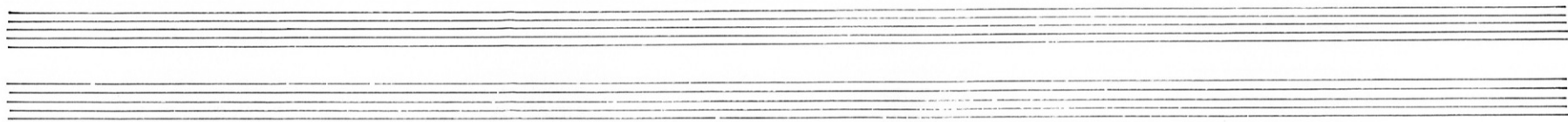
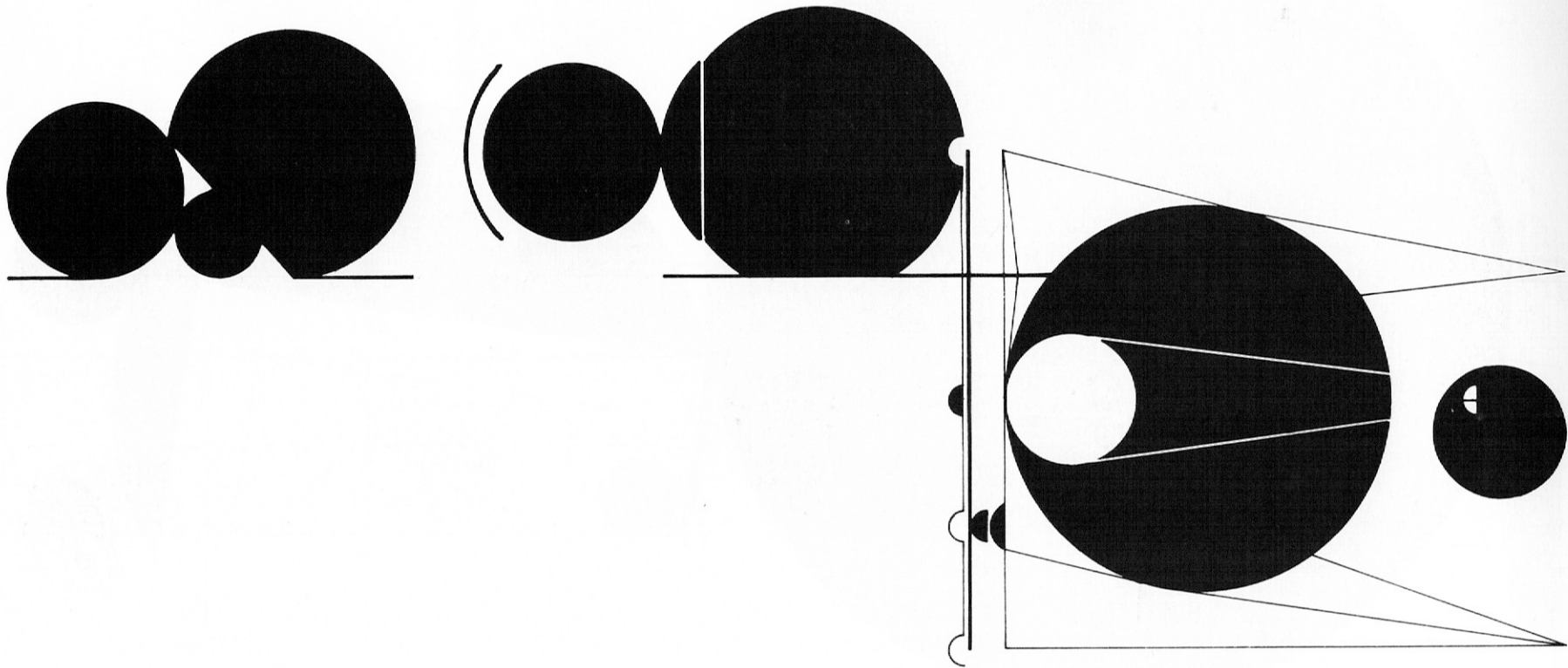

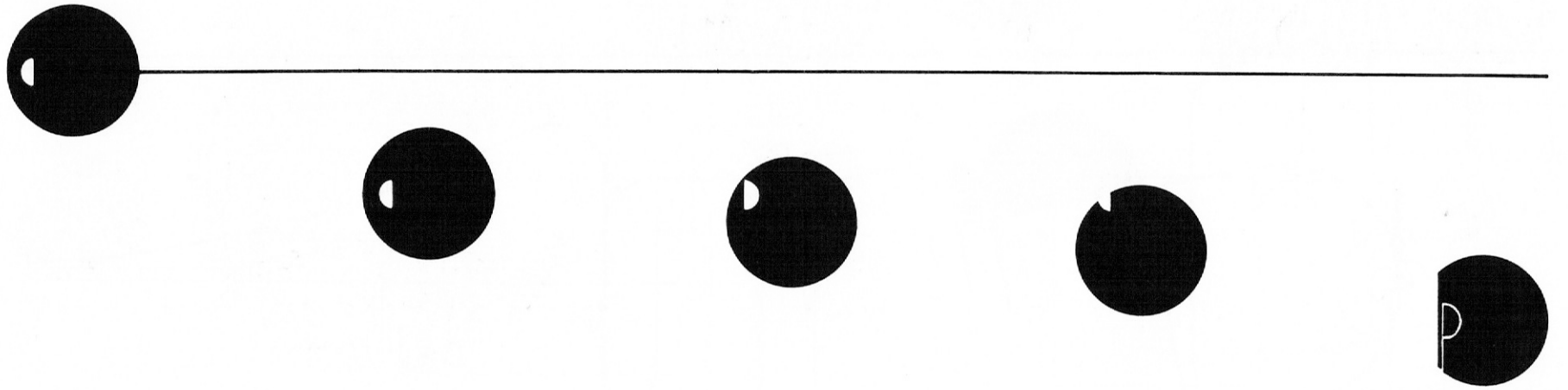

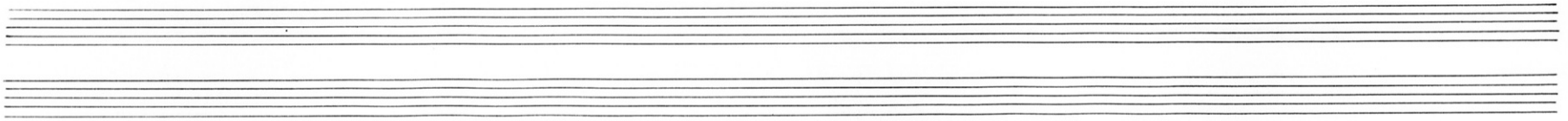
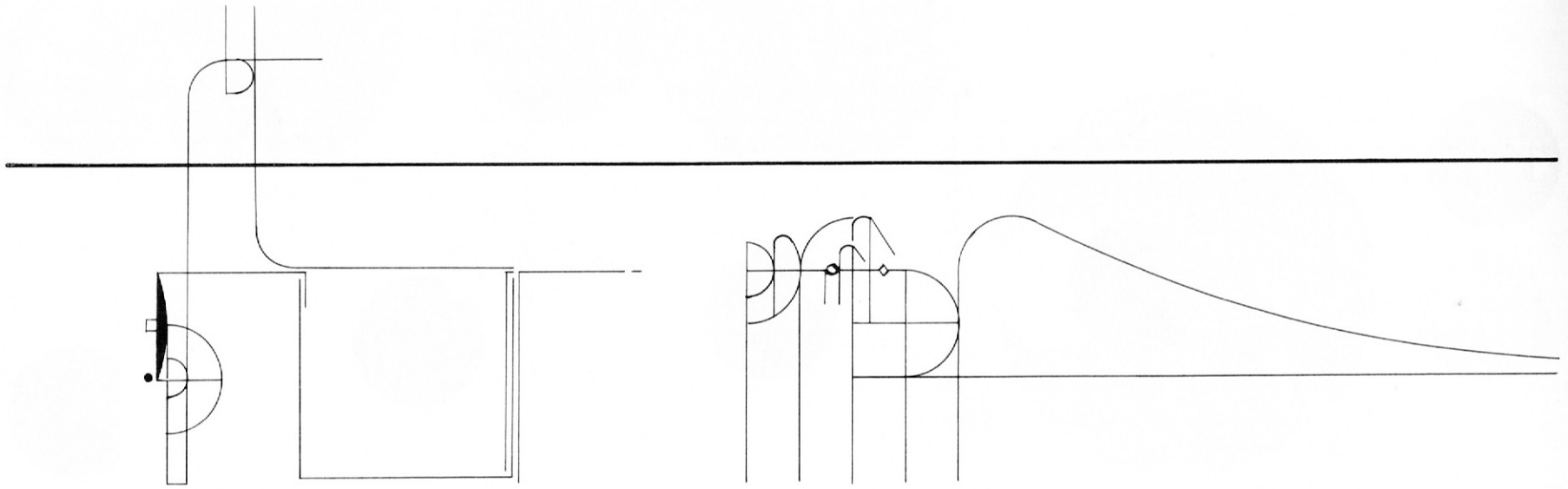

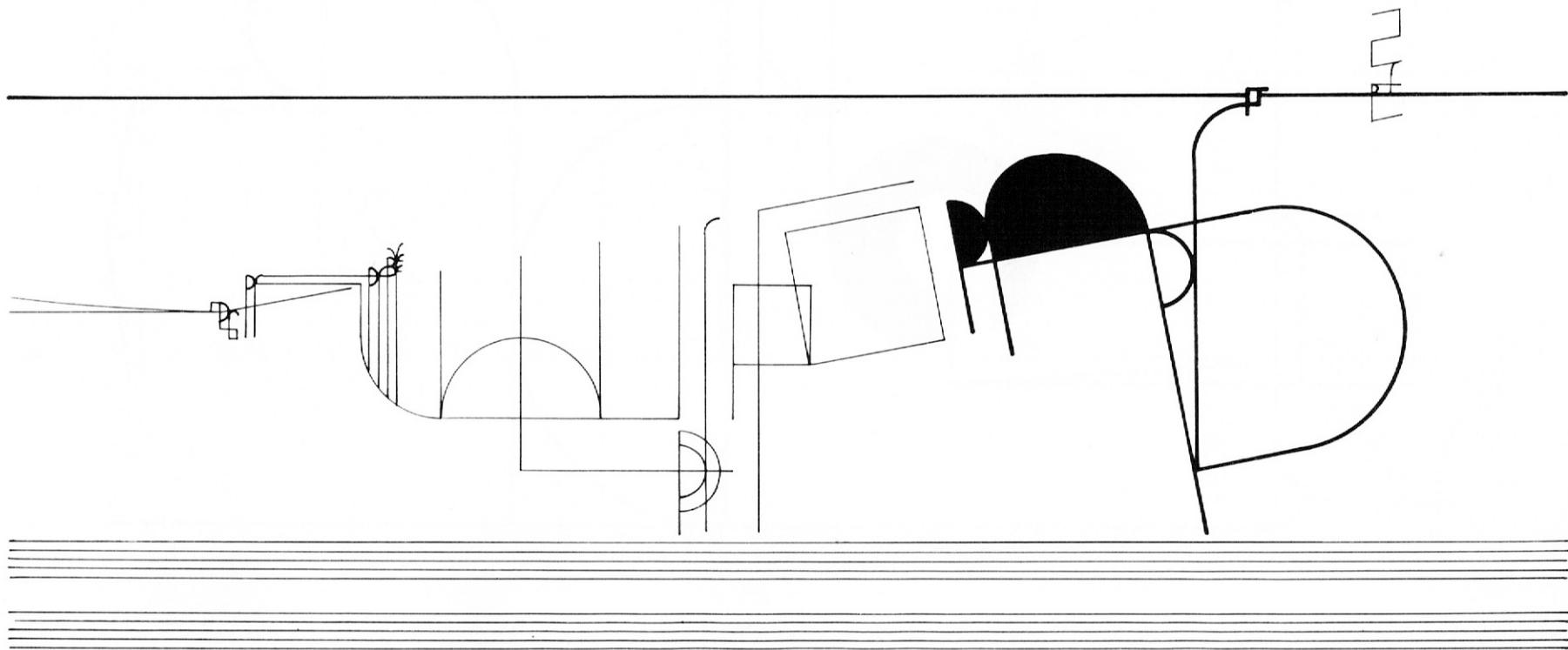

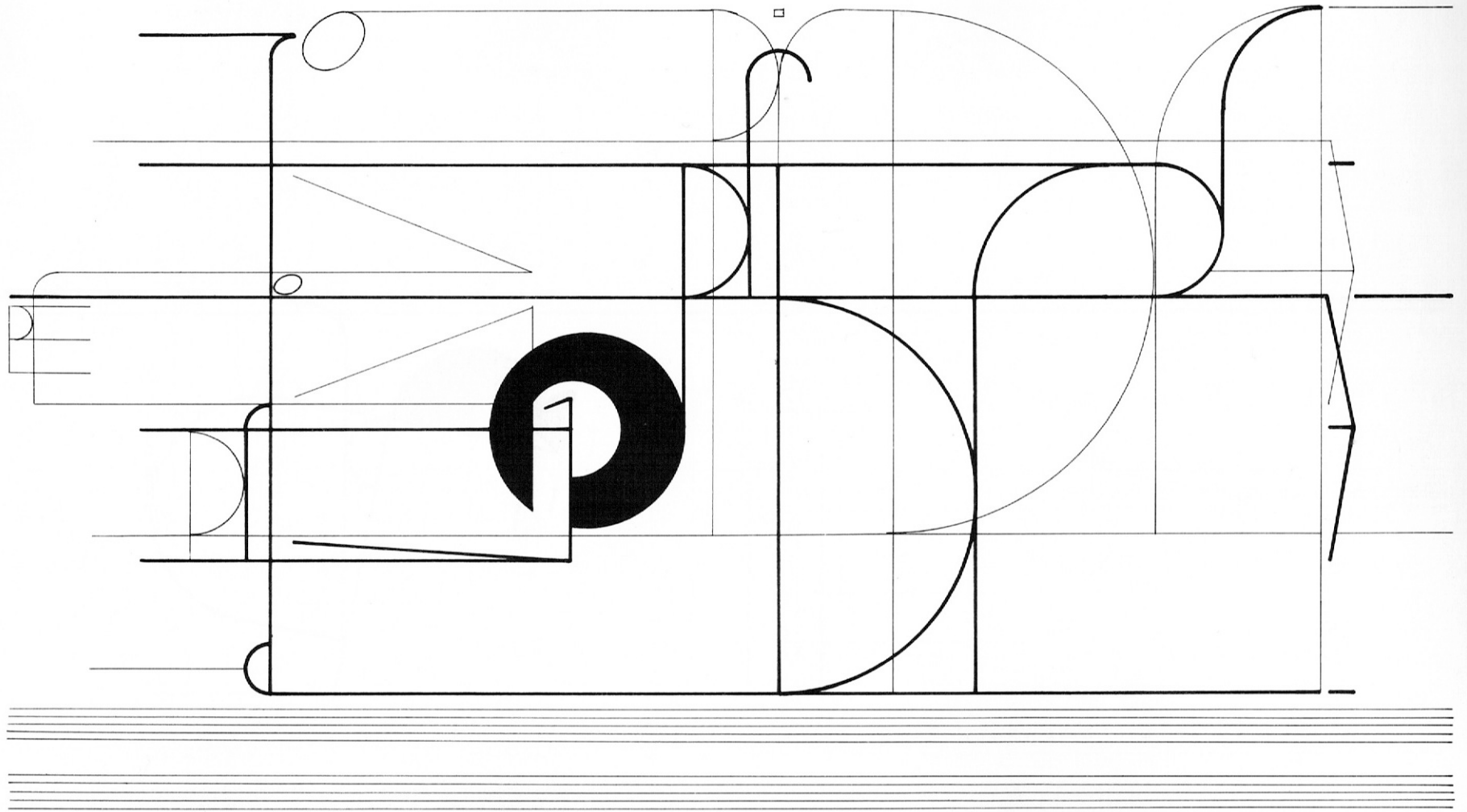

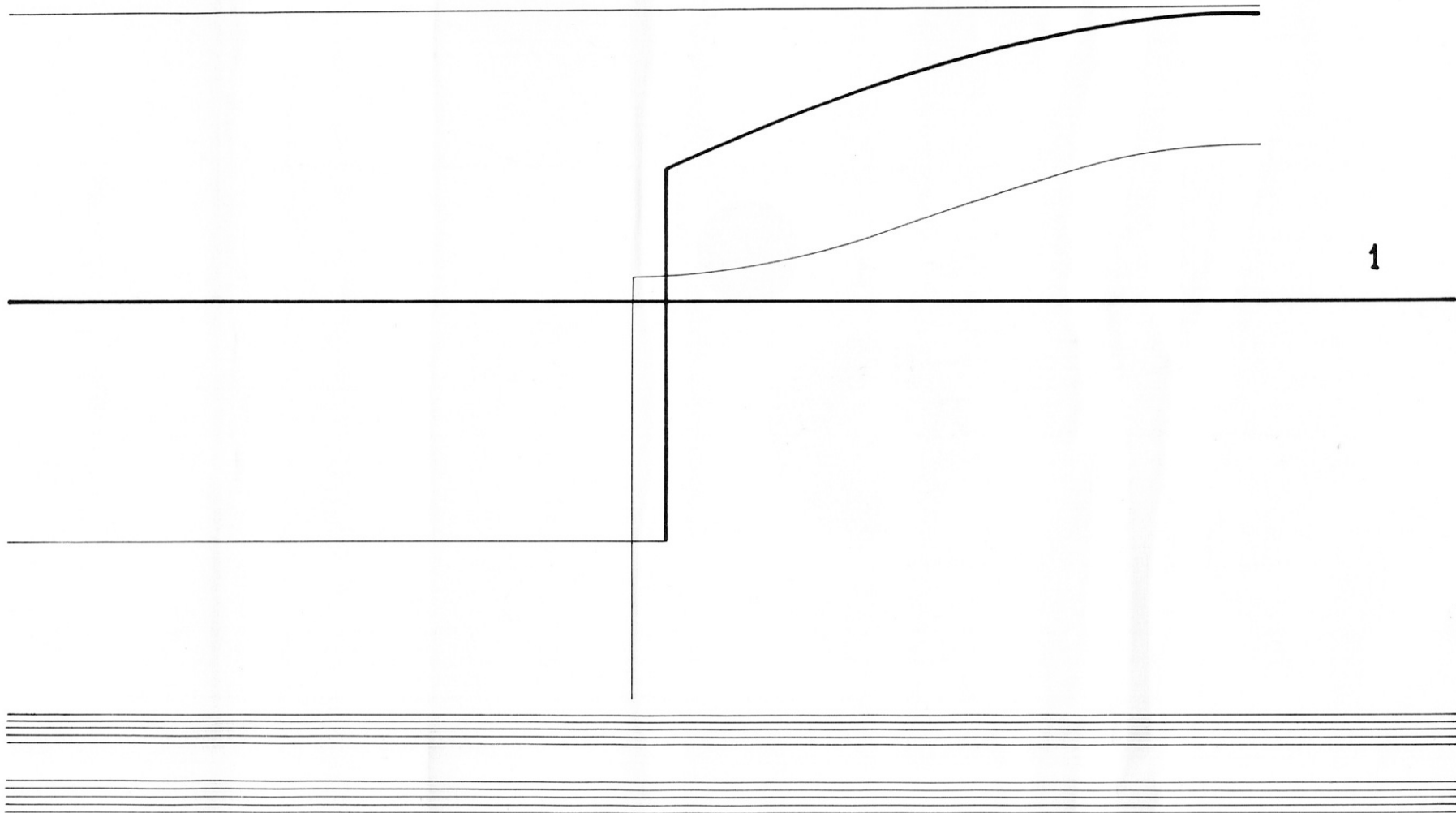

1

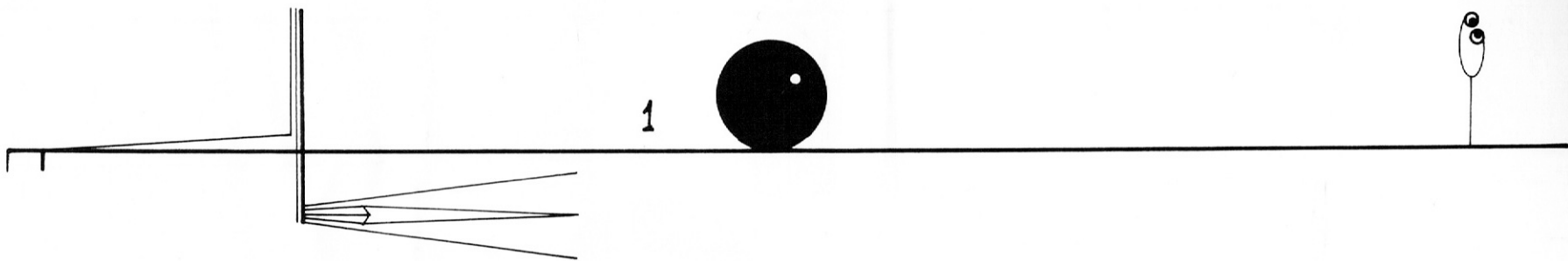



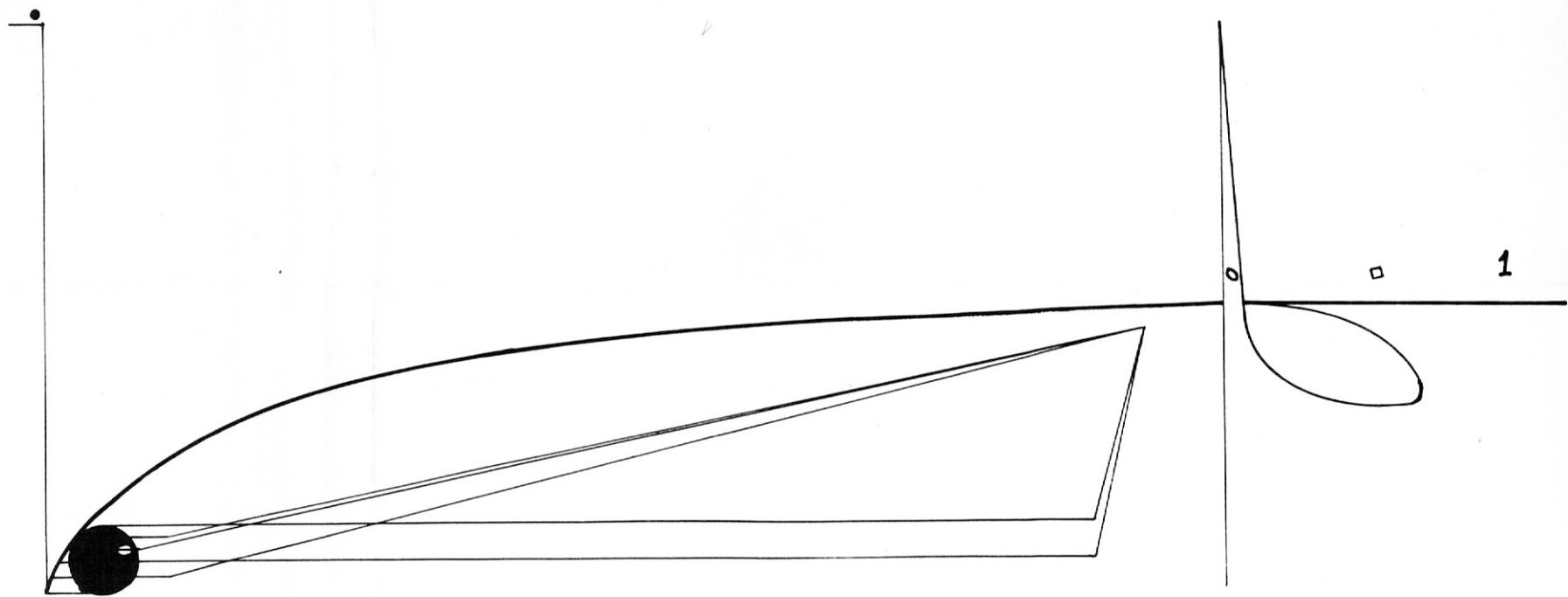

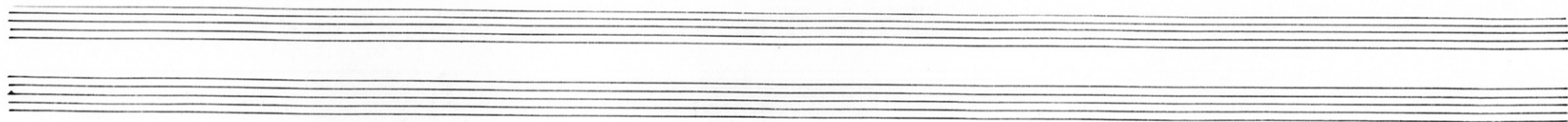
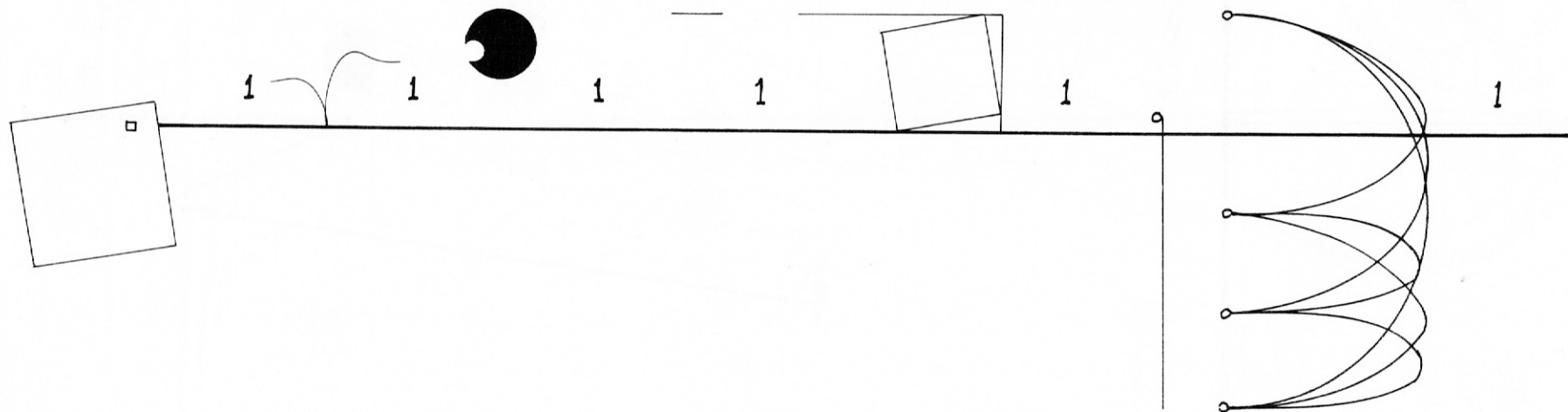

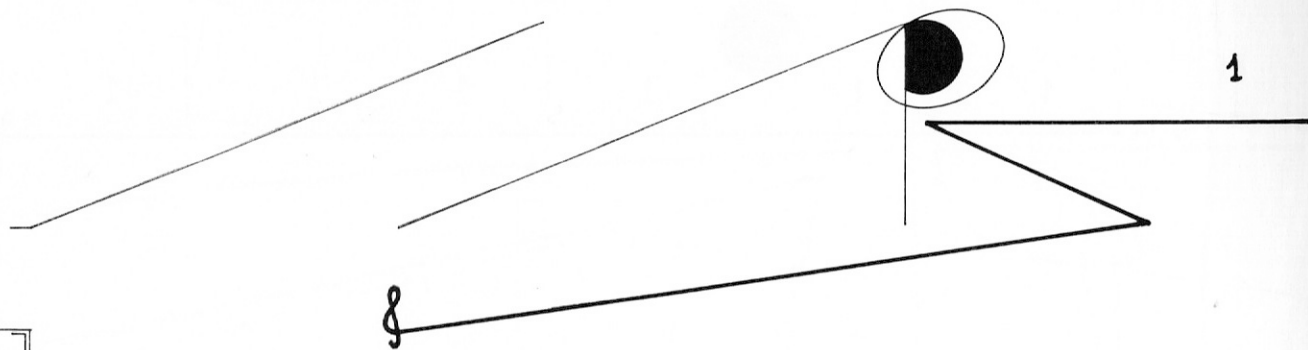
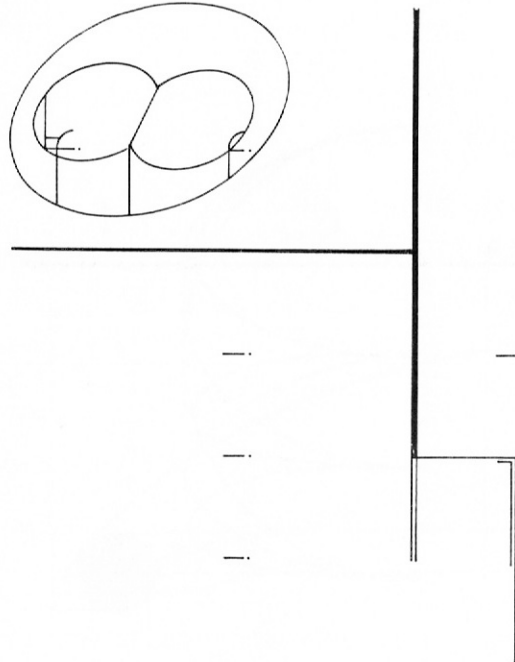
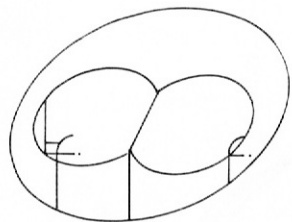

1

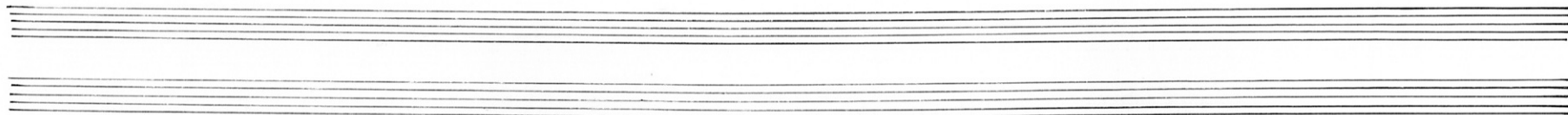

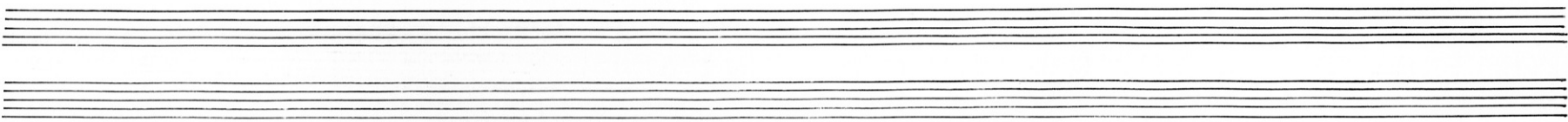
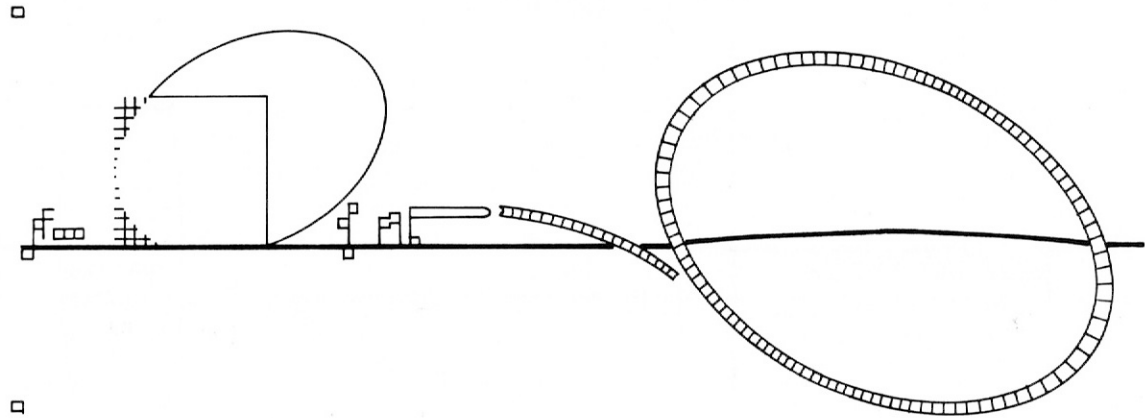
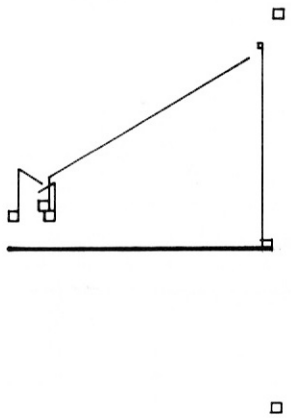

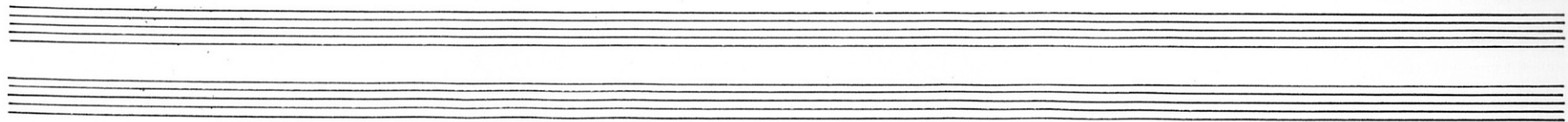
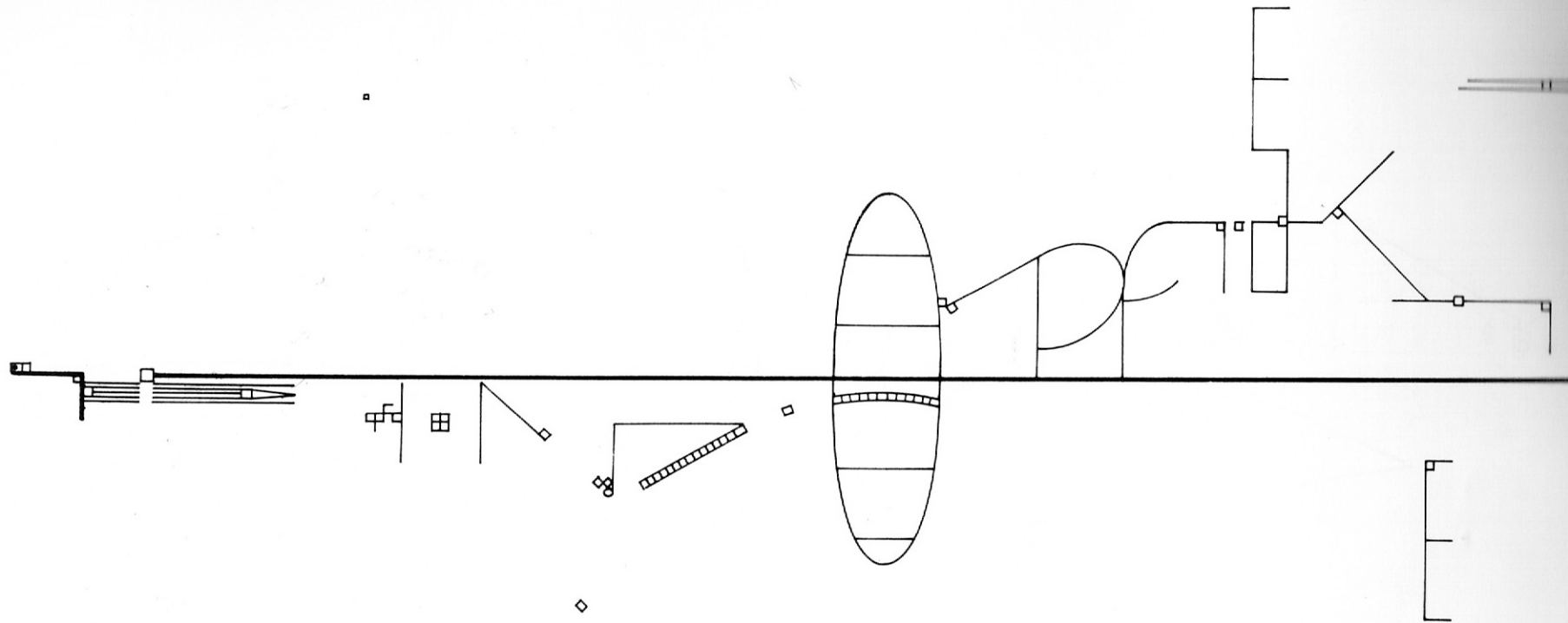

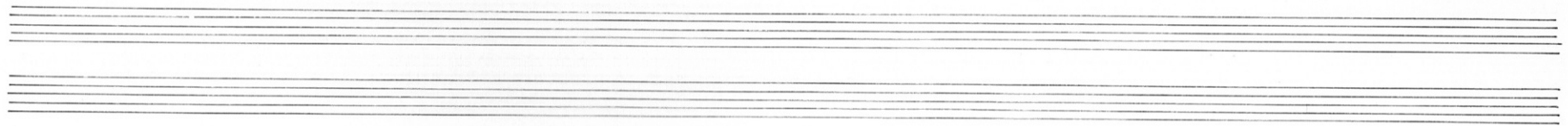
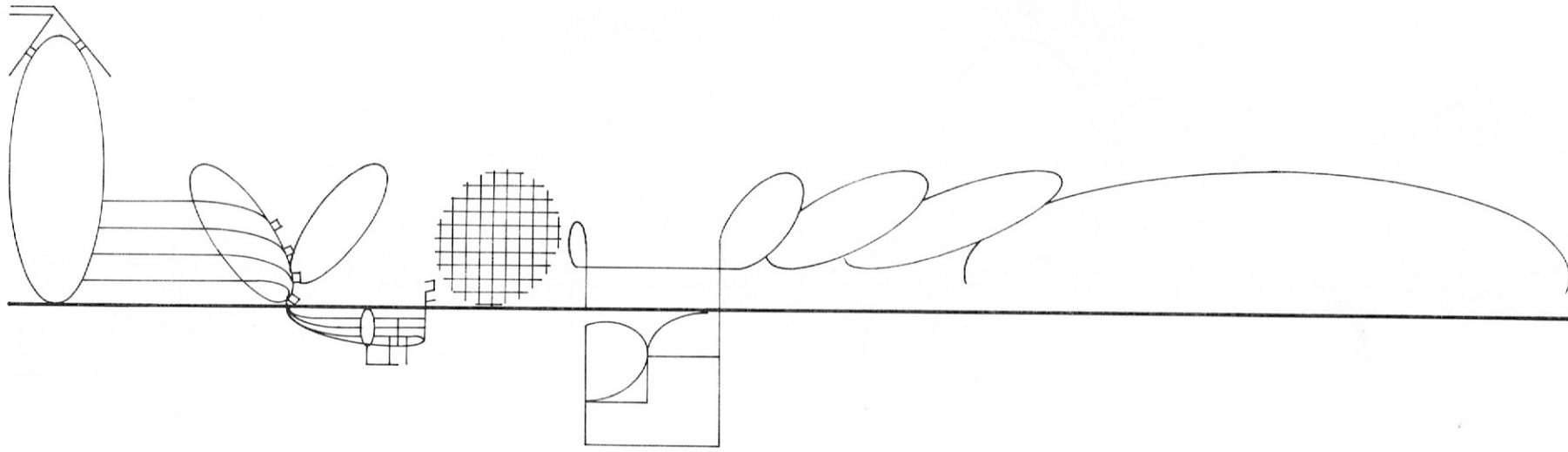

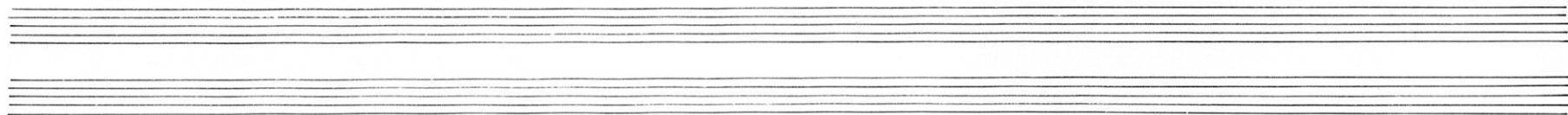
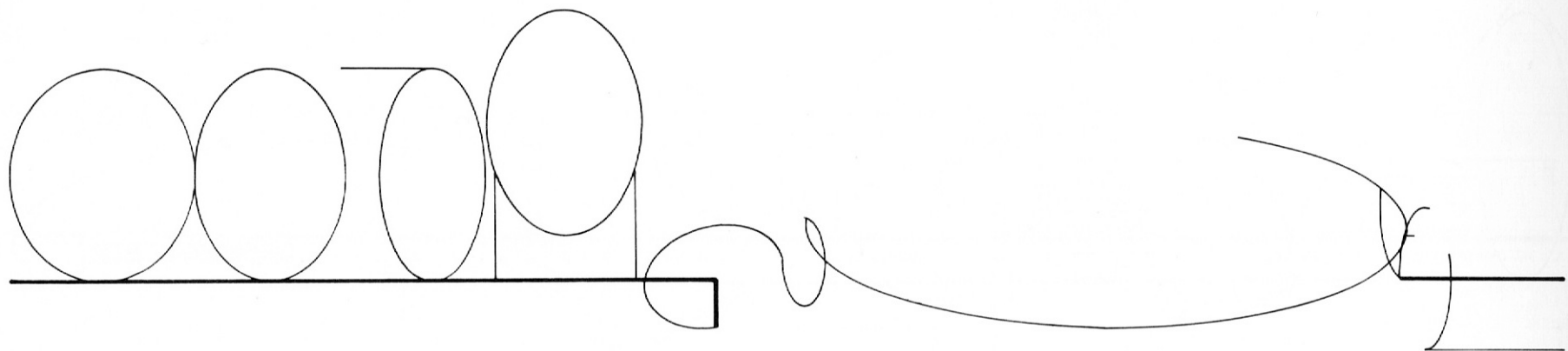

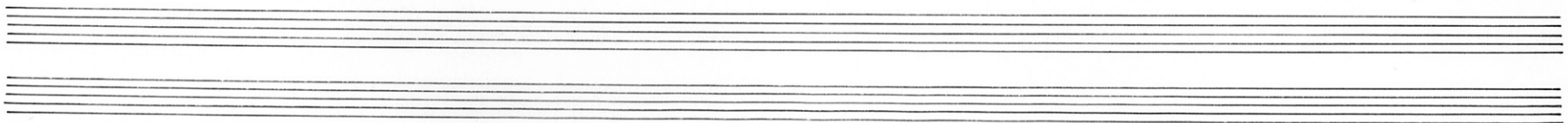
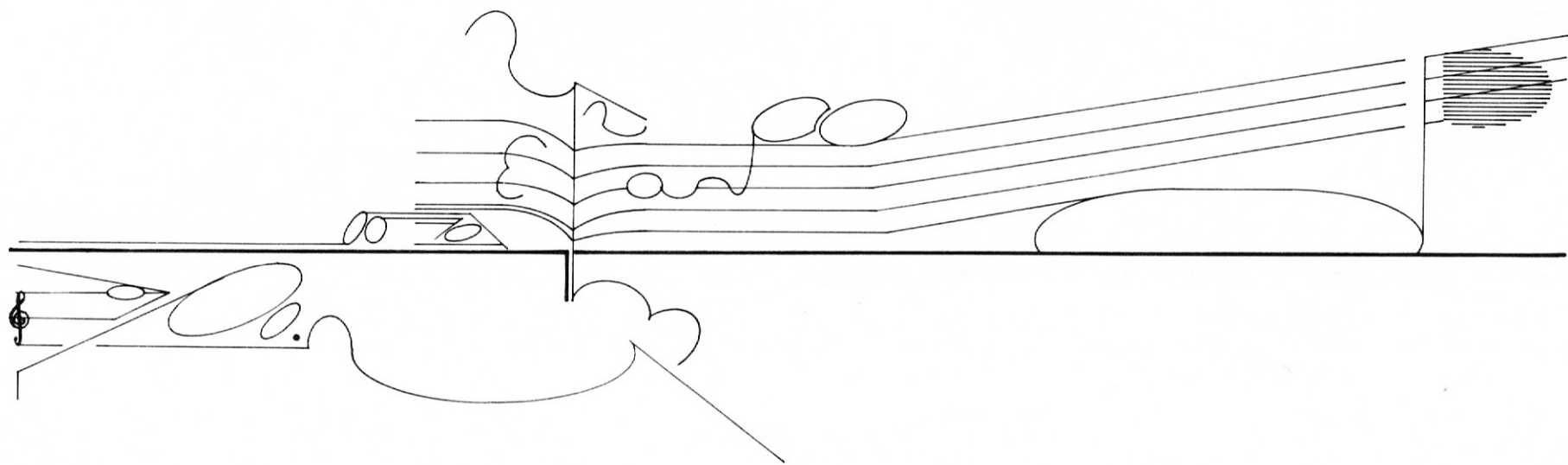

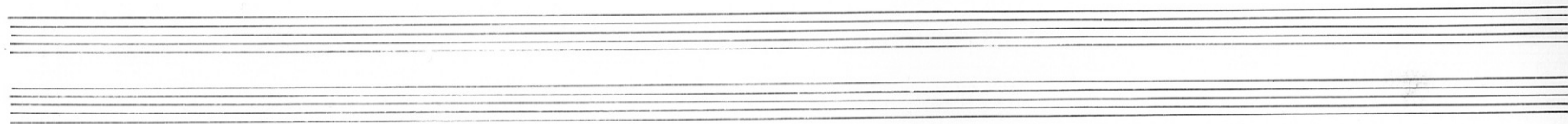
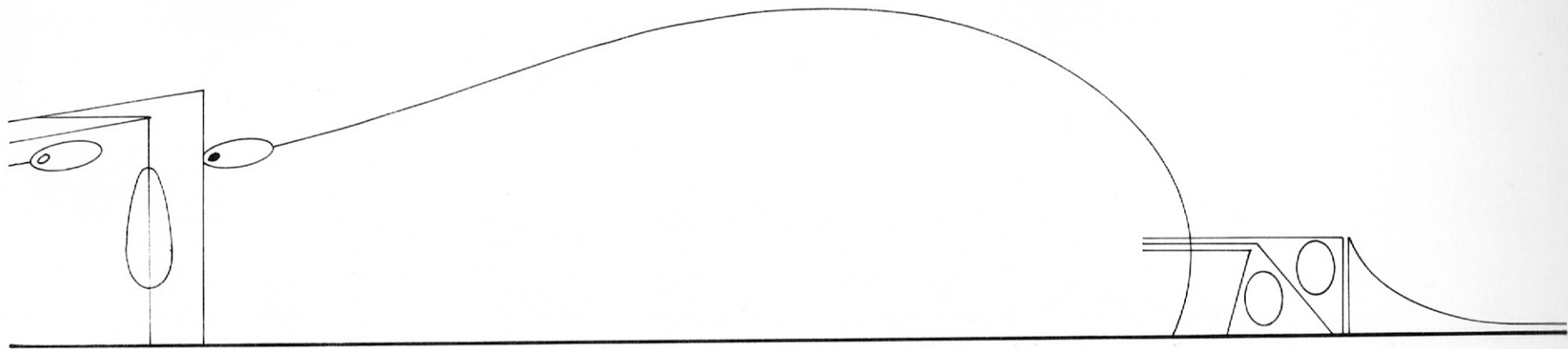

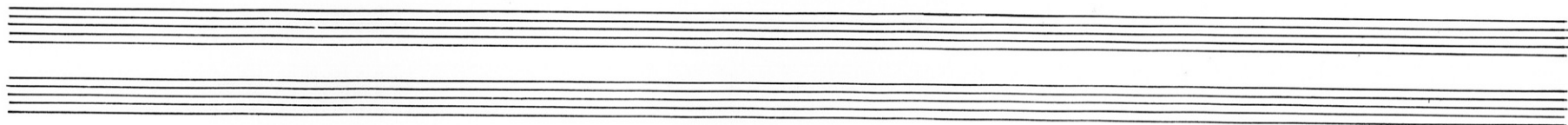
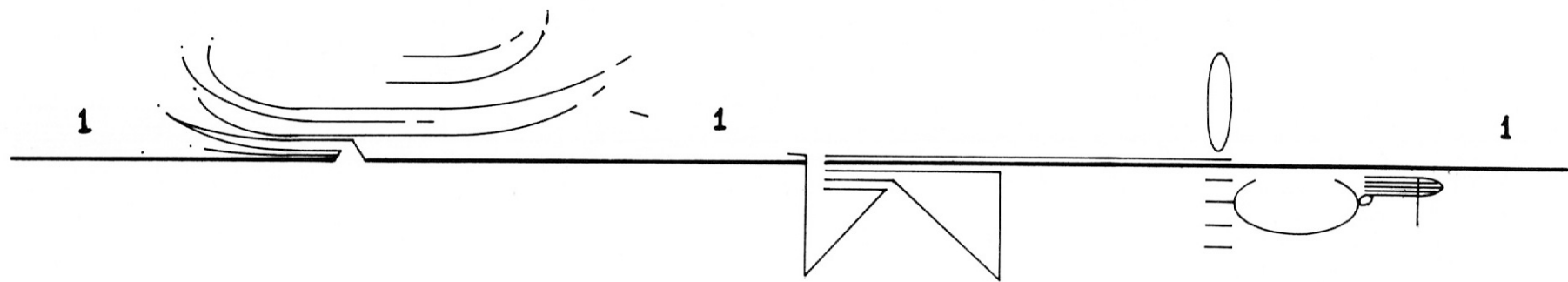

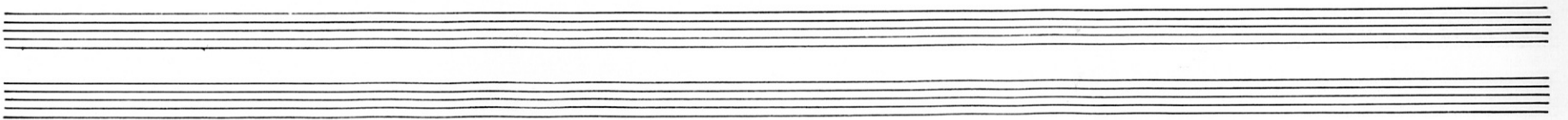
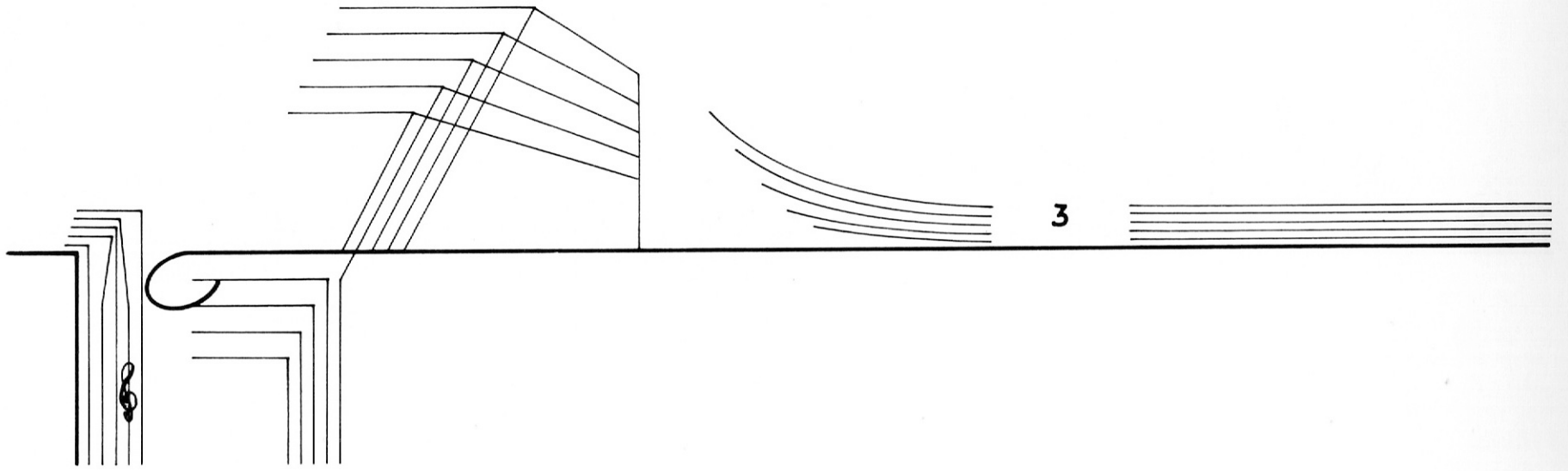

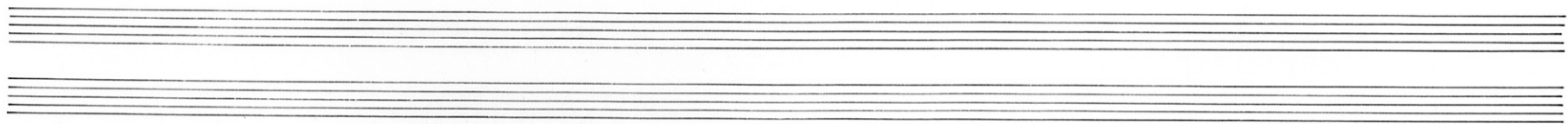
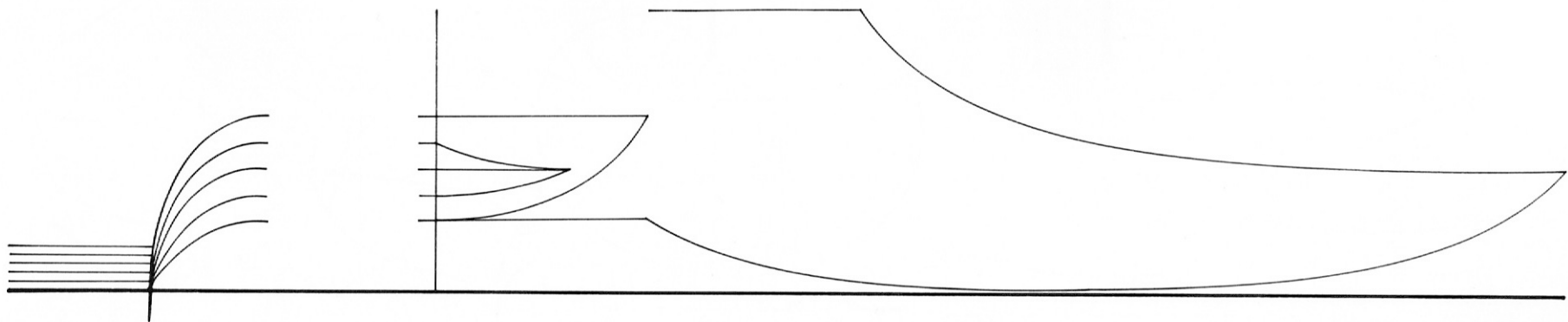

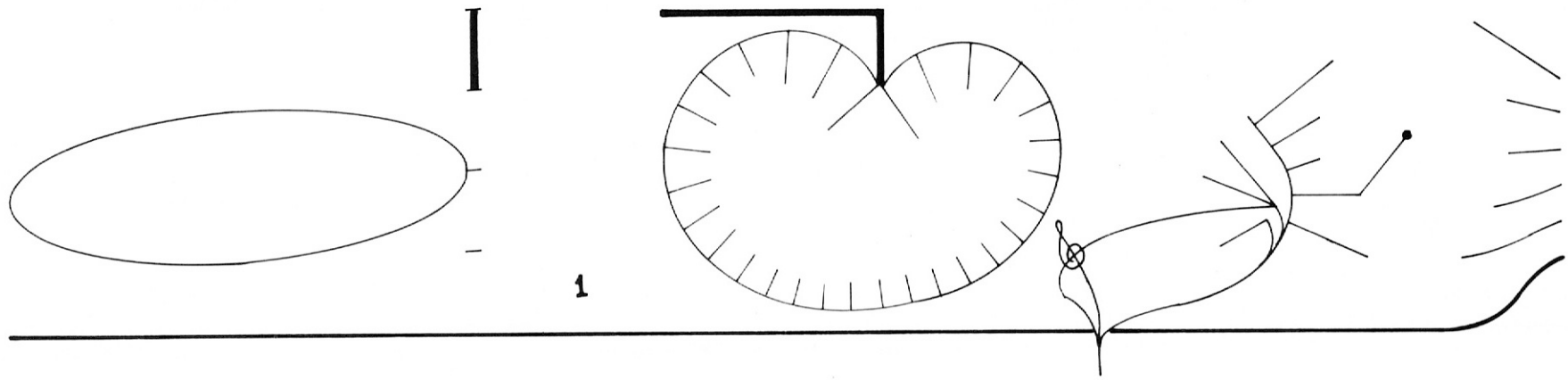

1

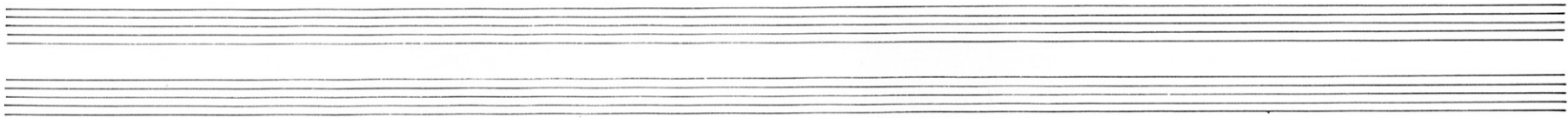

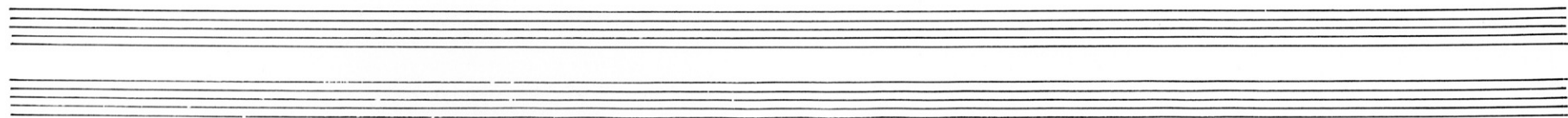
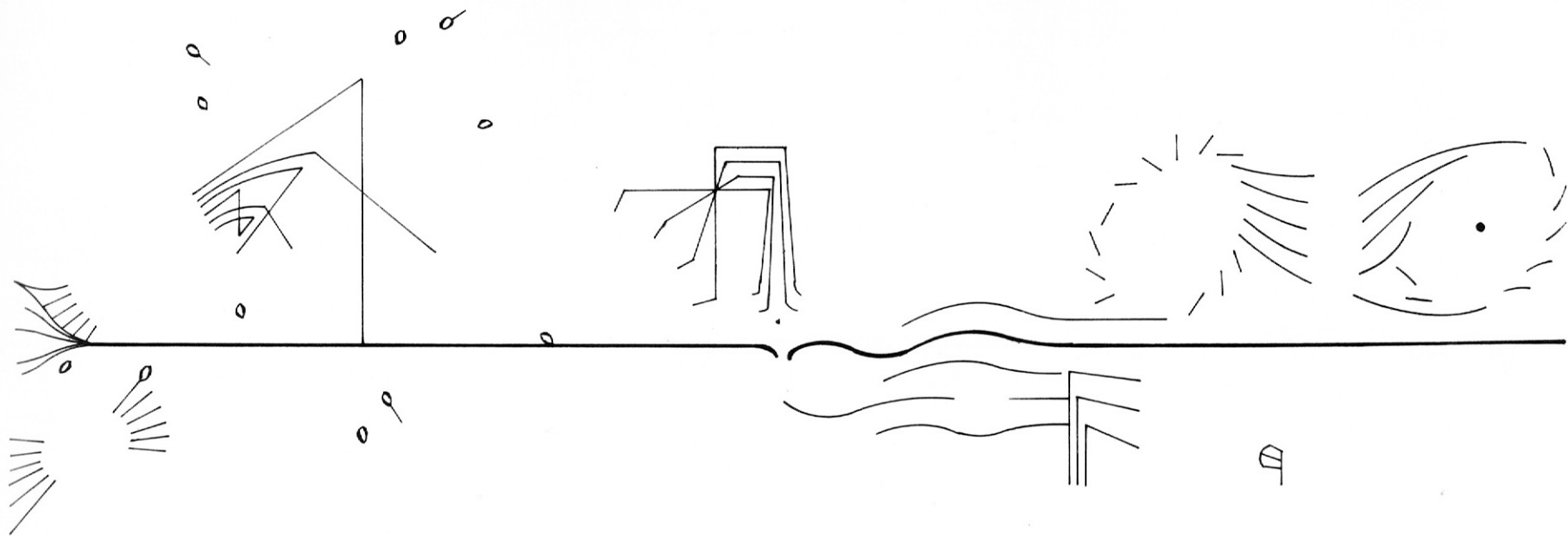

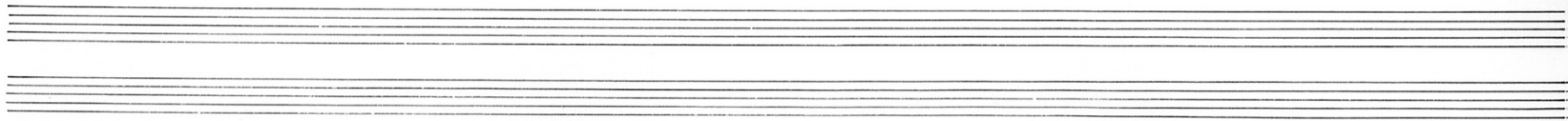
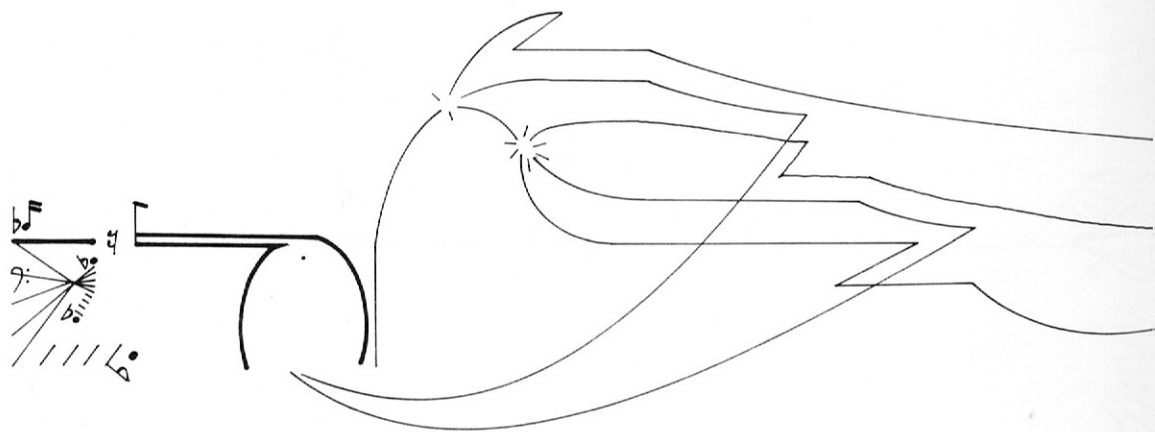
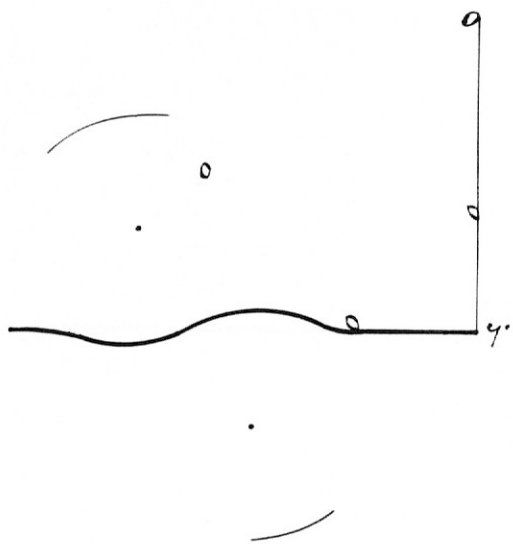

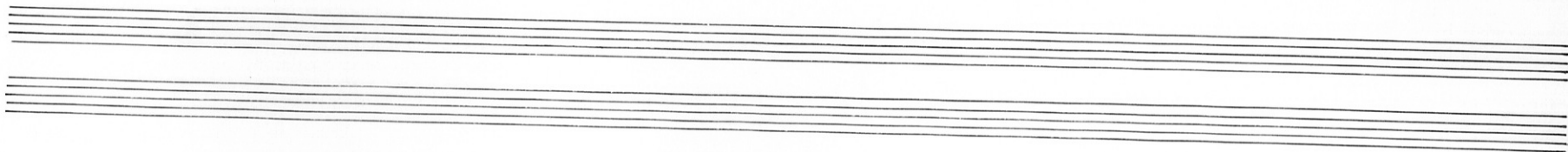
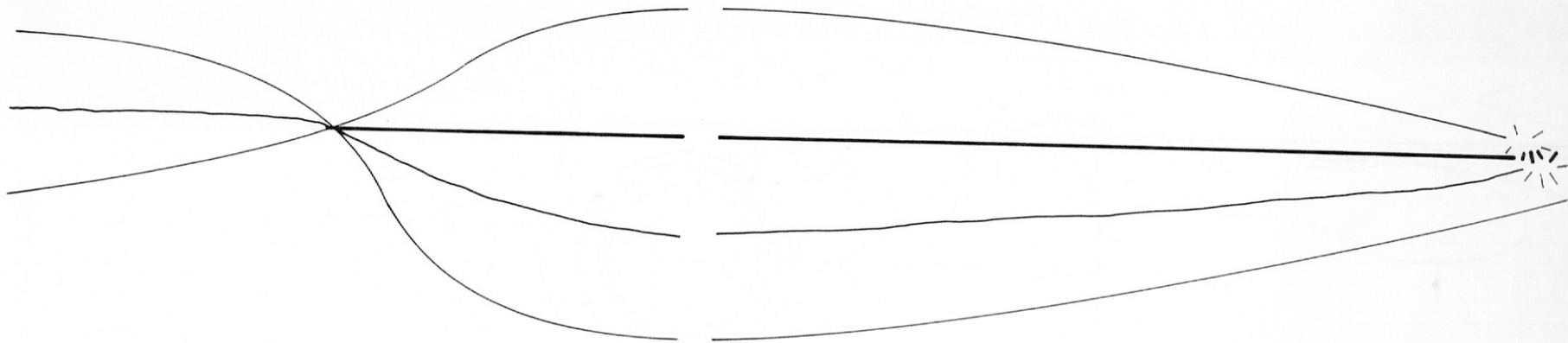

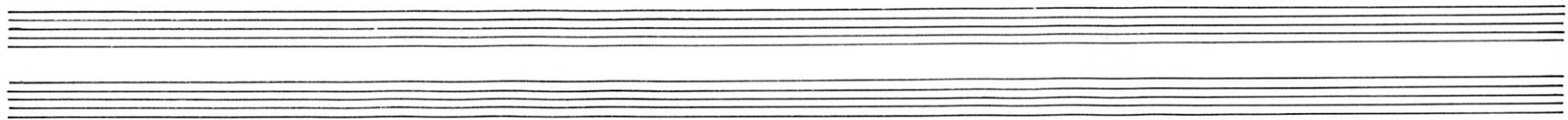
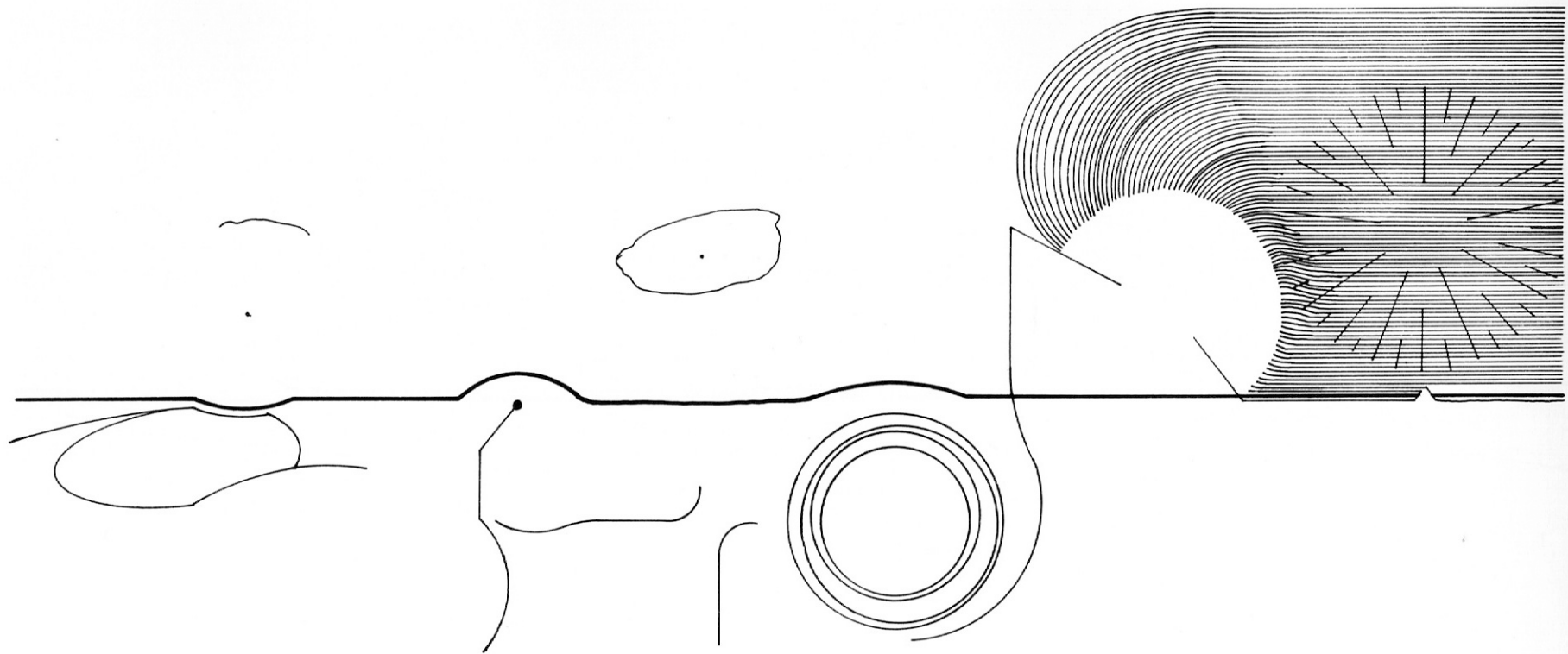

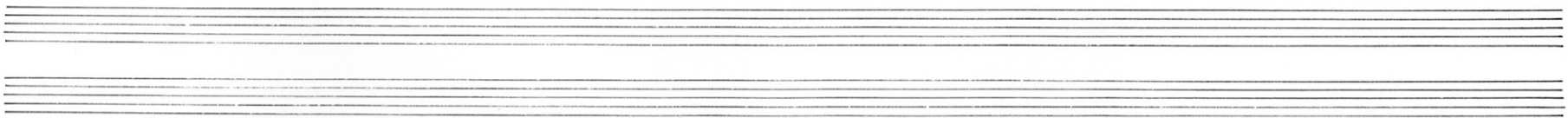
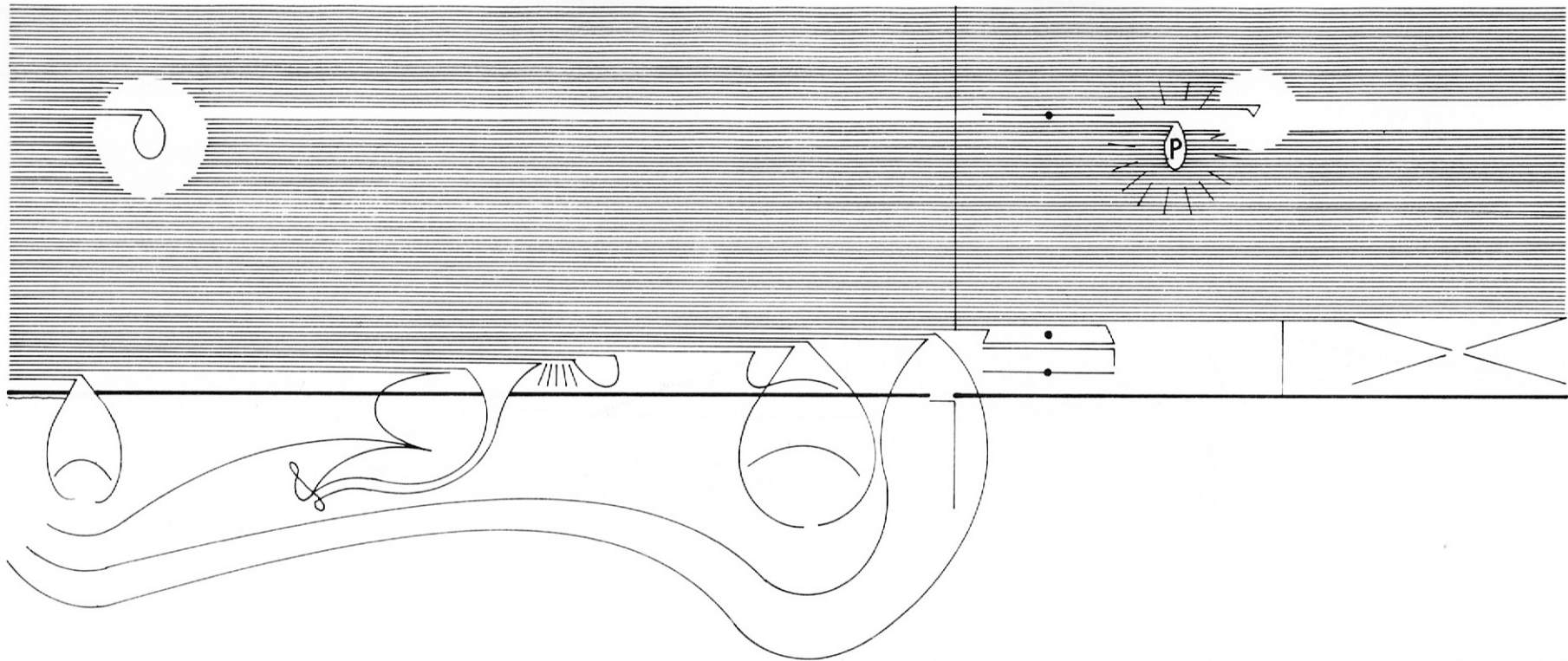

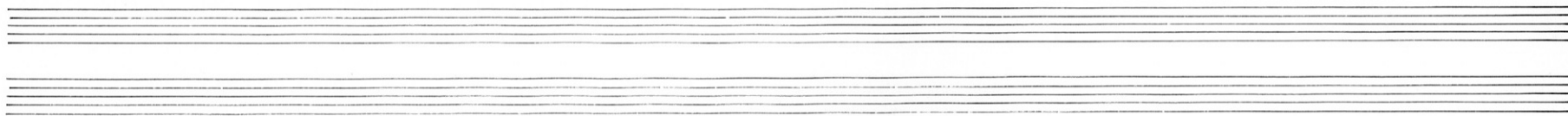
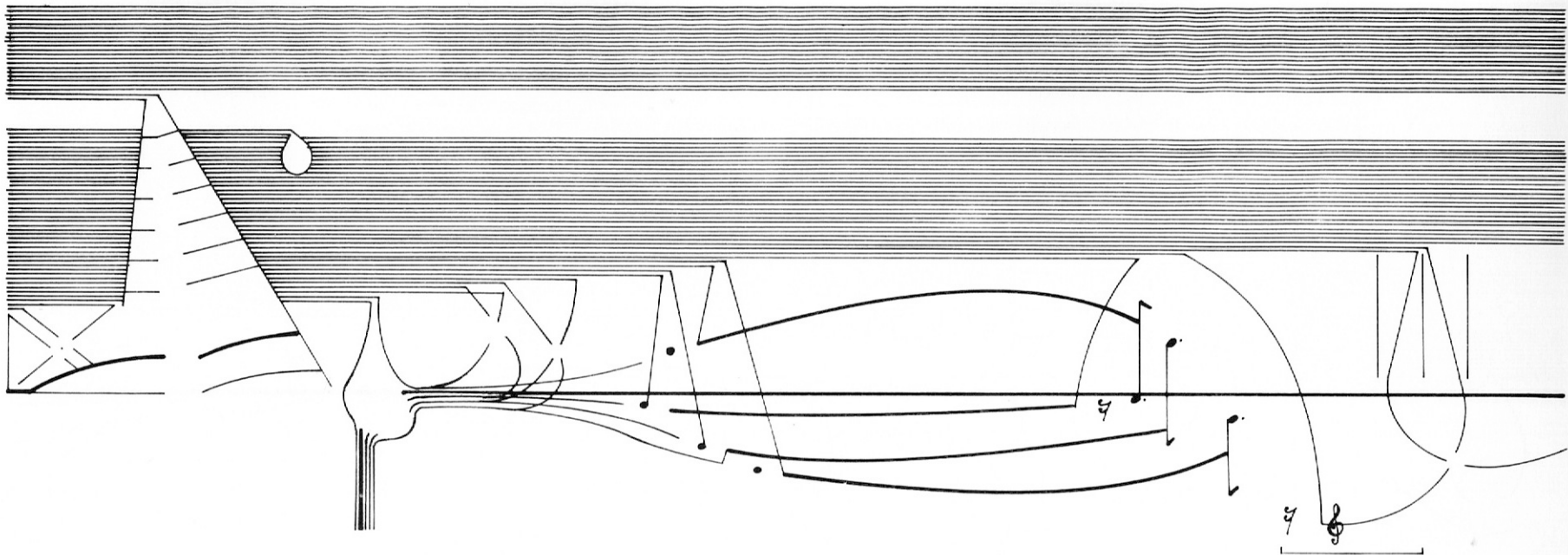

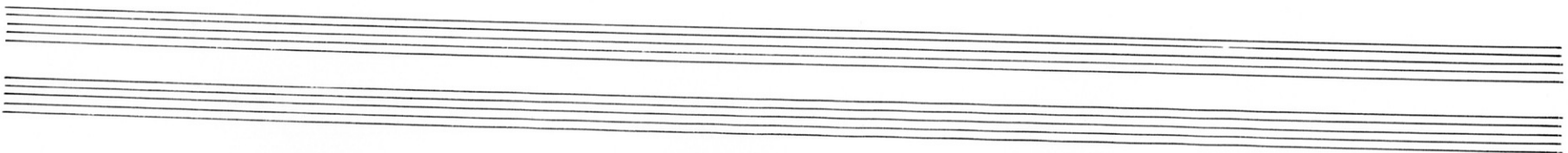
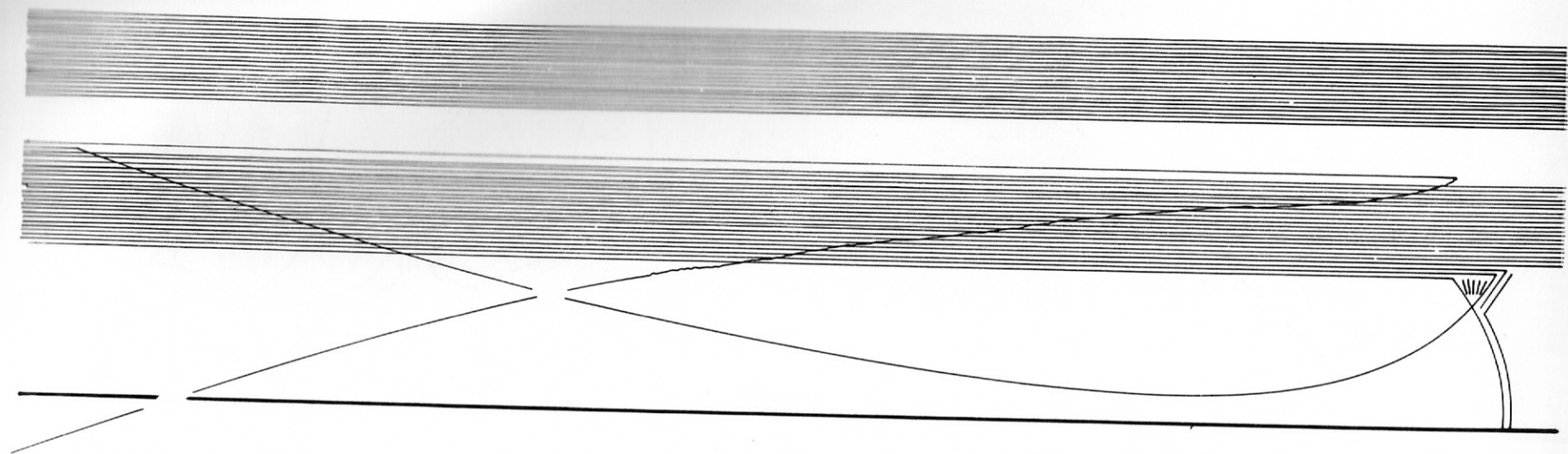

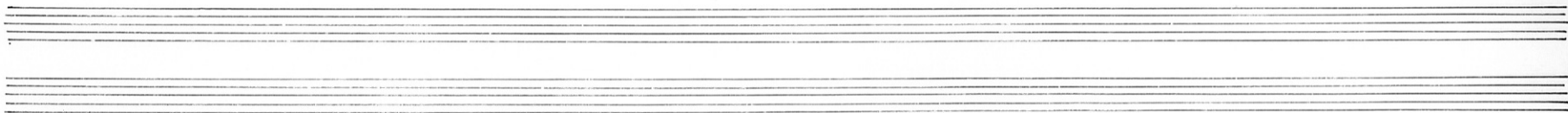
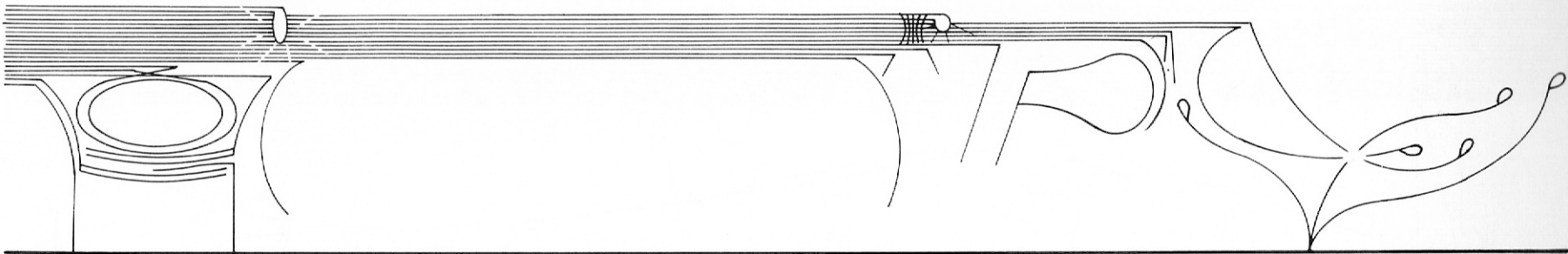

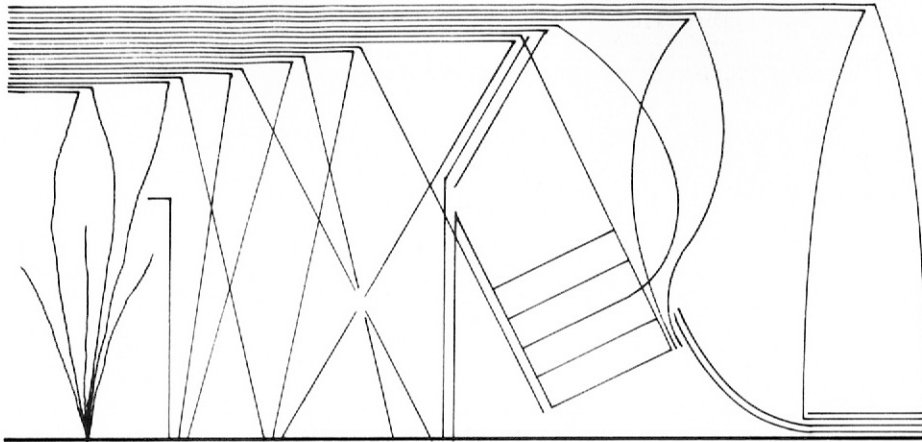

2

2

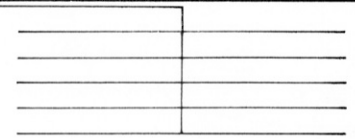
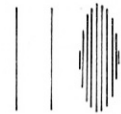

Handwritten musical notation on a staff. The notation includes a bass clef, a flat sign (b), and a treble clef. The notes are connected by a line that leads to a large, empty rectangular box. The box is defined by two parallel lines and is positioned to the right of the musical staff.

Two sets of empty musical staves, each consisting of five horizontal lines, positioned below the main musical notation.

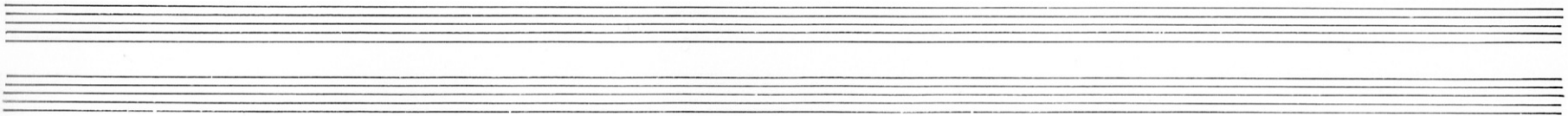
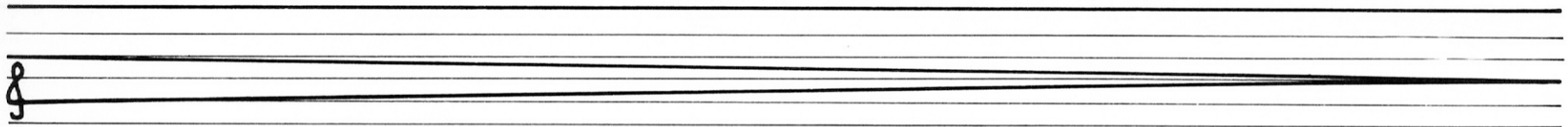



?

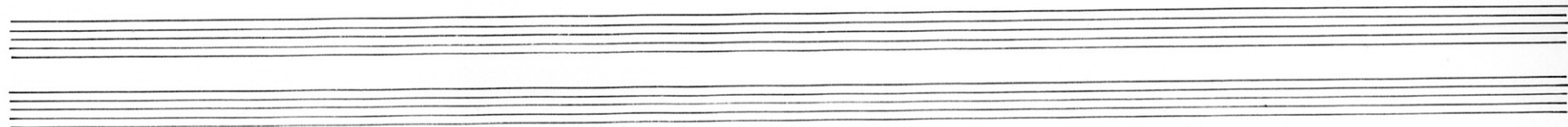
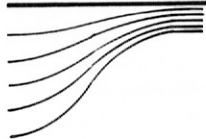

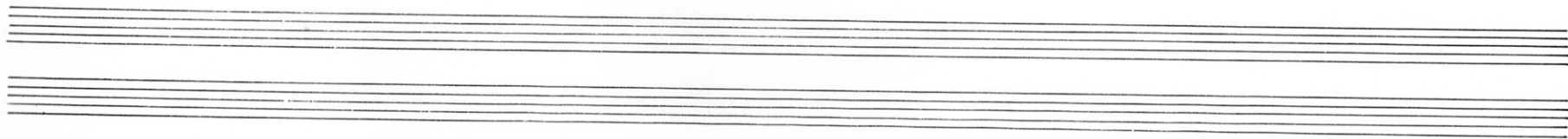
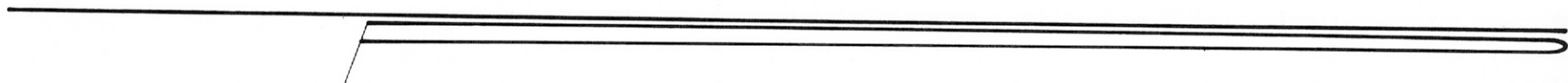

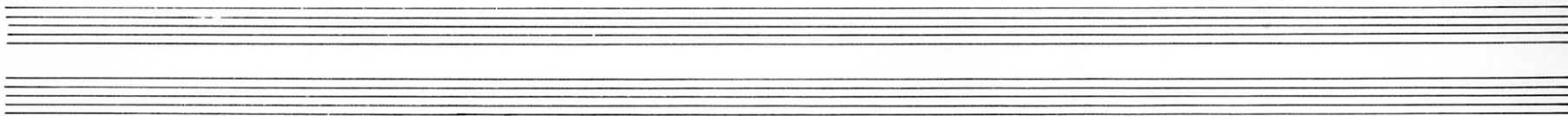

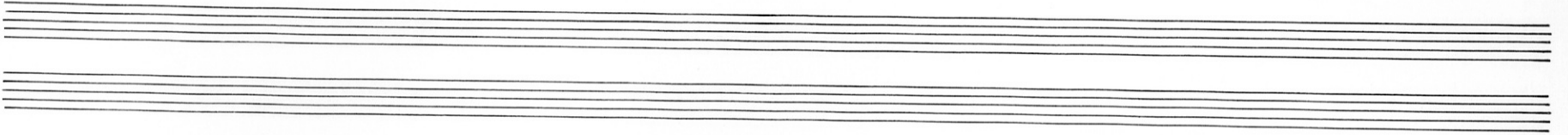
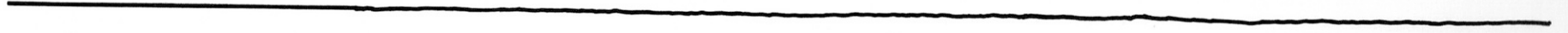

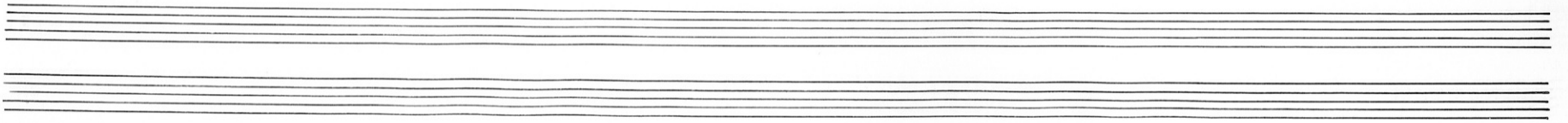
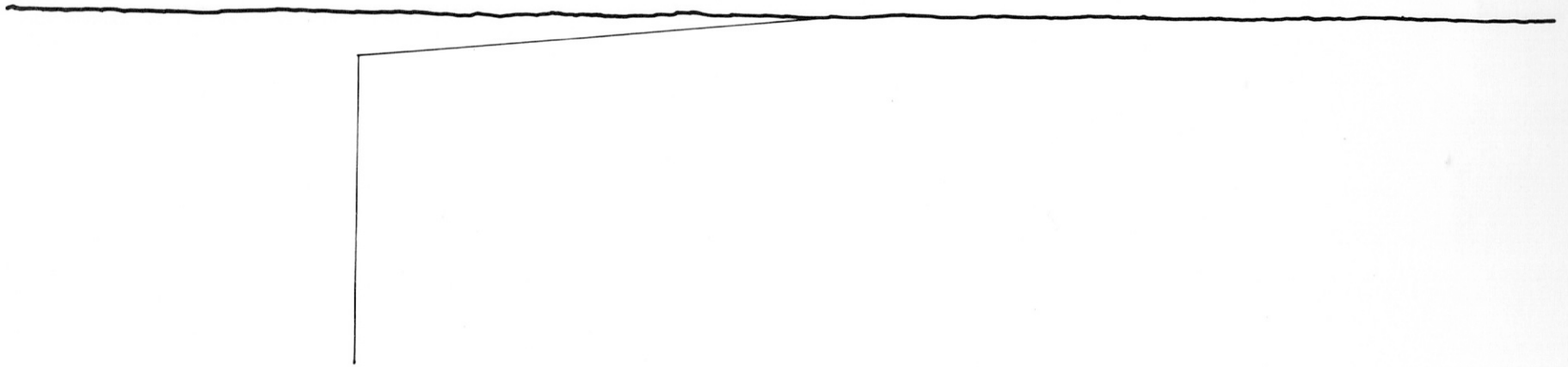

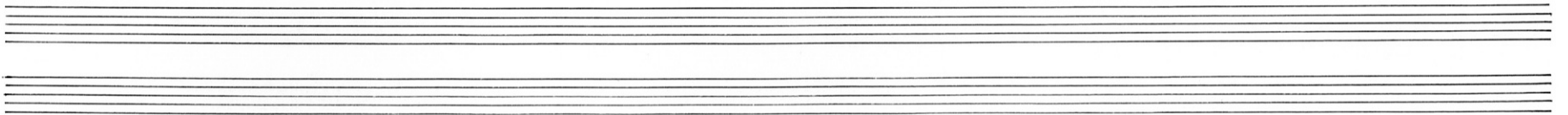

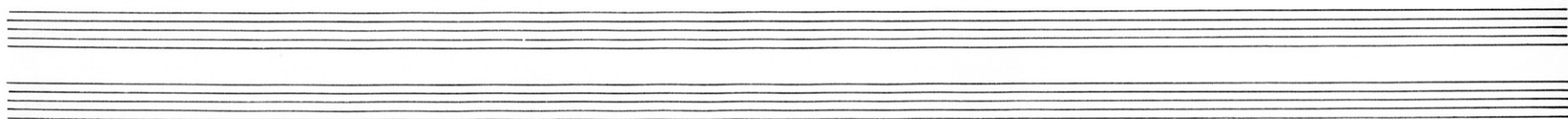
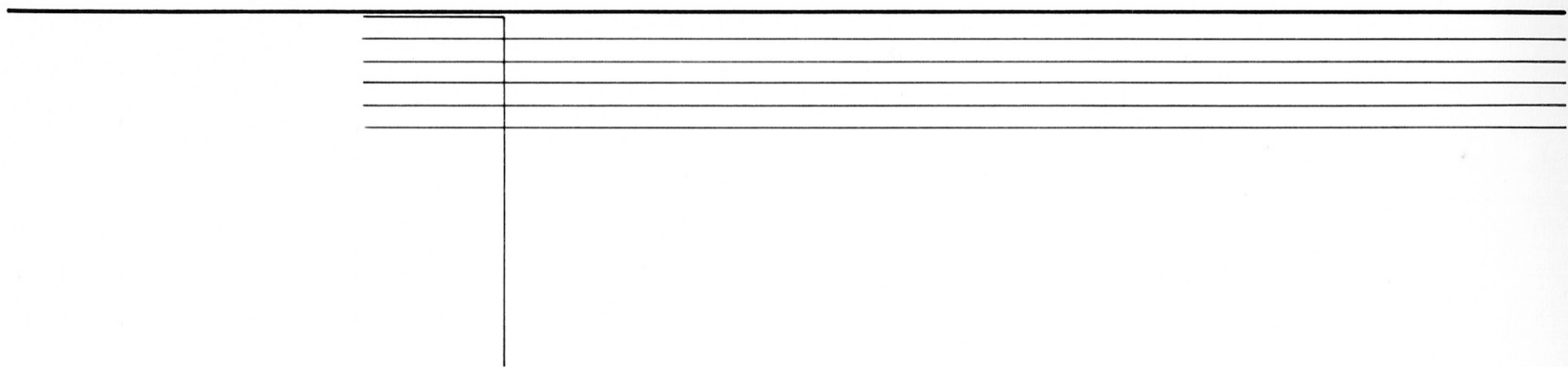

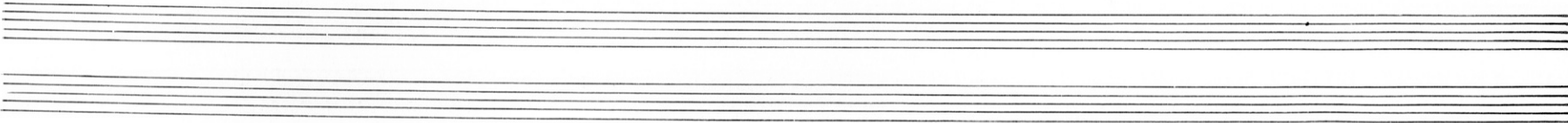

The left page of the musical score features several staves. At the top, there are two staves with a thick horizontal line. Below them, a large, empty oval is drawn across two staves. Further down, a musical staff with a treble clef contains a slur over two notes, with fingerings '6', '4', '3', '2', '1', and '5' written vertically below the notes. A vertical bar line is positioned to the right of these staves.

The right page of the musical score shows a single musical staff with a half note. A vertical bar line is placed at the end of the staff, followed by a dynamic marking 'p' (piano).

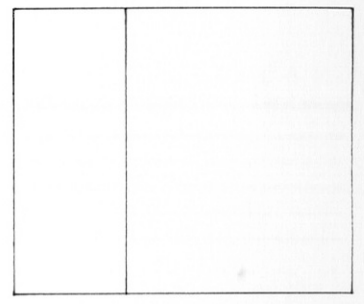

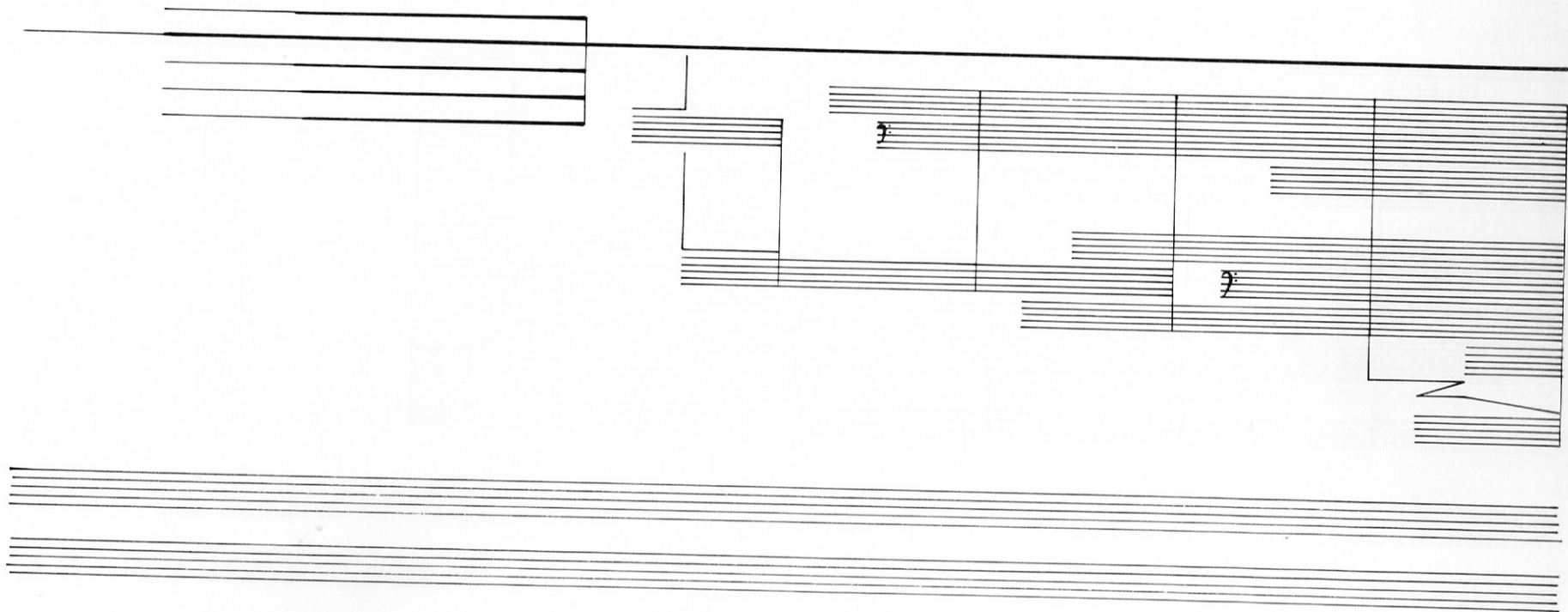



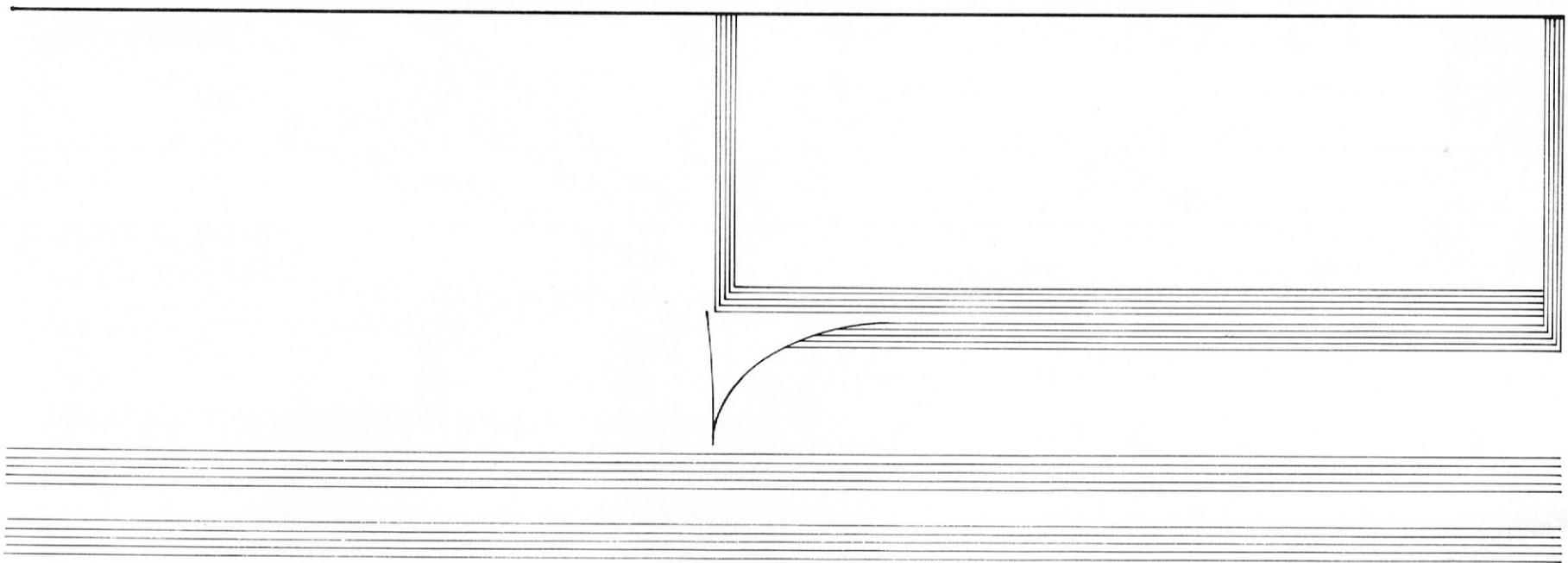

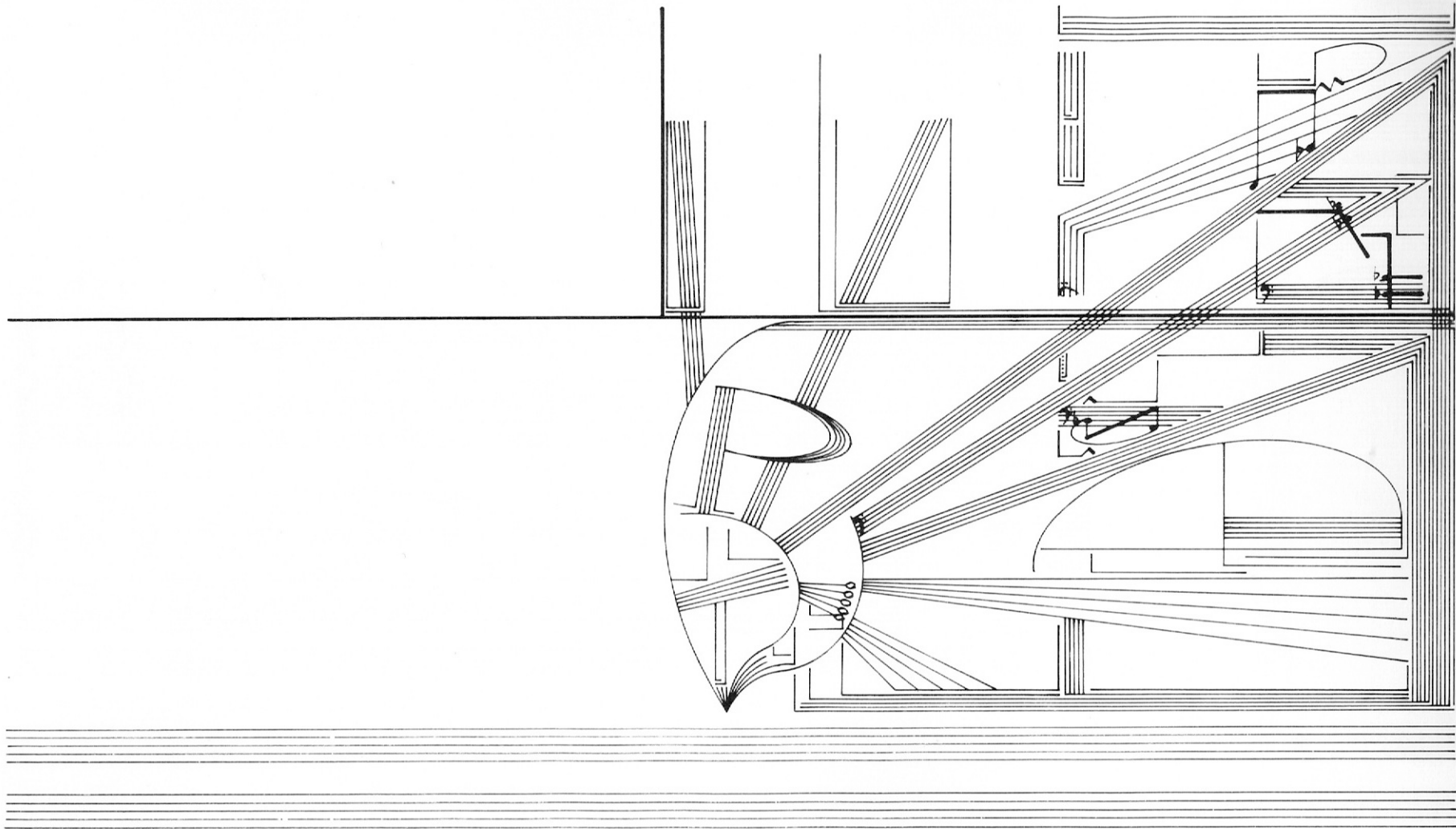

A hand-drawn musical score on a page. The score is oriented vertically, with the top of the page being the right side of the image. It features several staves. On the left side (top of the page), there are three staves: the top one has a treble clef and a key signature of one flat; the middle one has a bass clef and a key signature of one flat; the bottom one has a treble clef. A large, hand-drawn oval is positioned in the upper right quadrant of the page, with a long line extending from its bottom edge to a specific point on the top staff. The rest of the score consists of various musical notations, including notes, rests, and lines, some of which are connected to the oval by lines. The drawing is somewhat sketchy and appears to be a working draft or a conceptual sketch.

Two sets of empty musical staves at the bottom of the page. Each set consists of five horizontal lines, one for each staff. There are no notes or other markings on these staves.

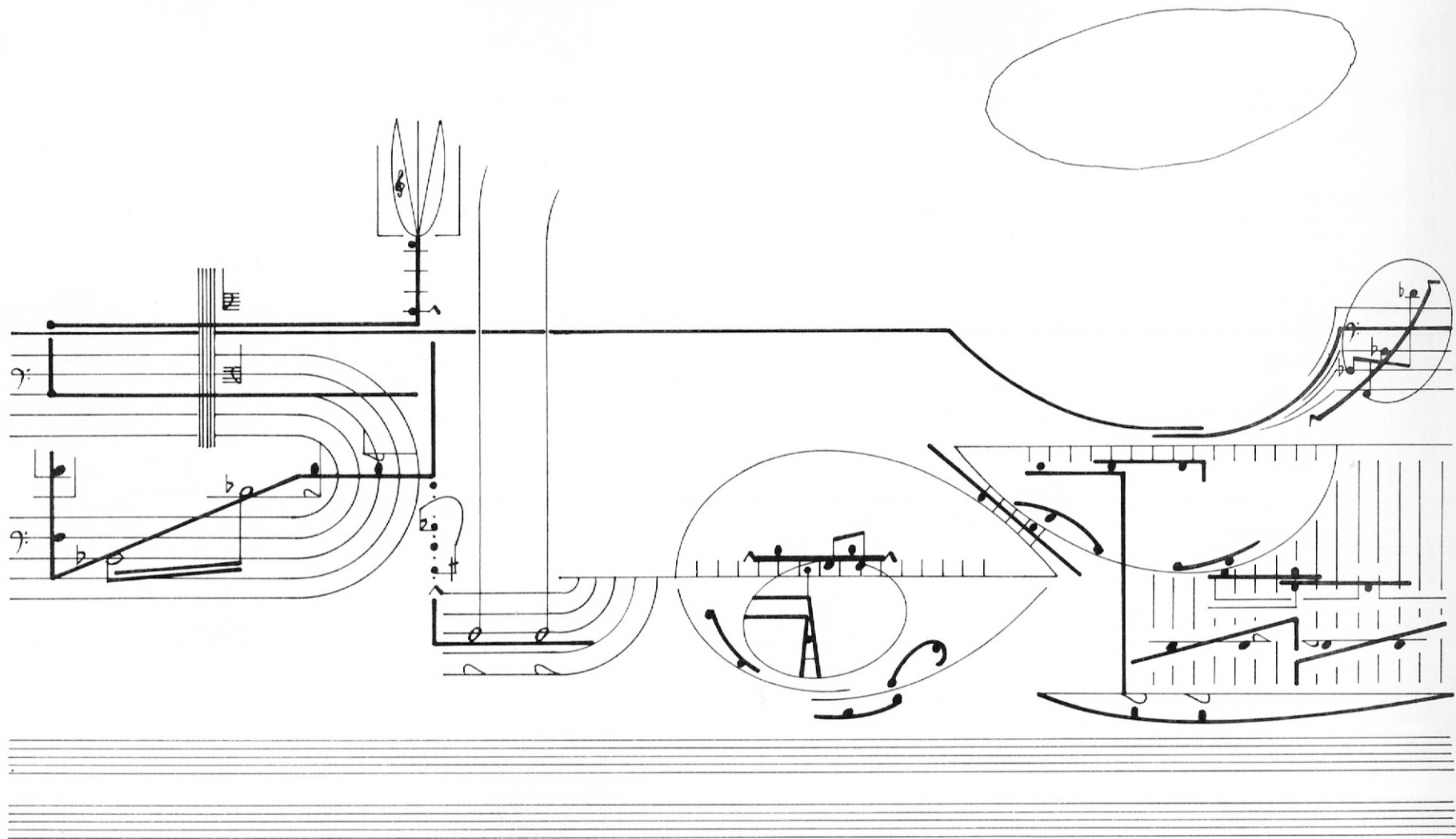

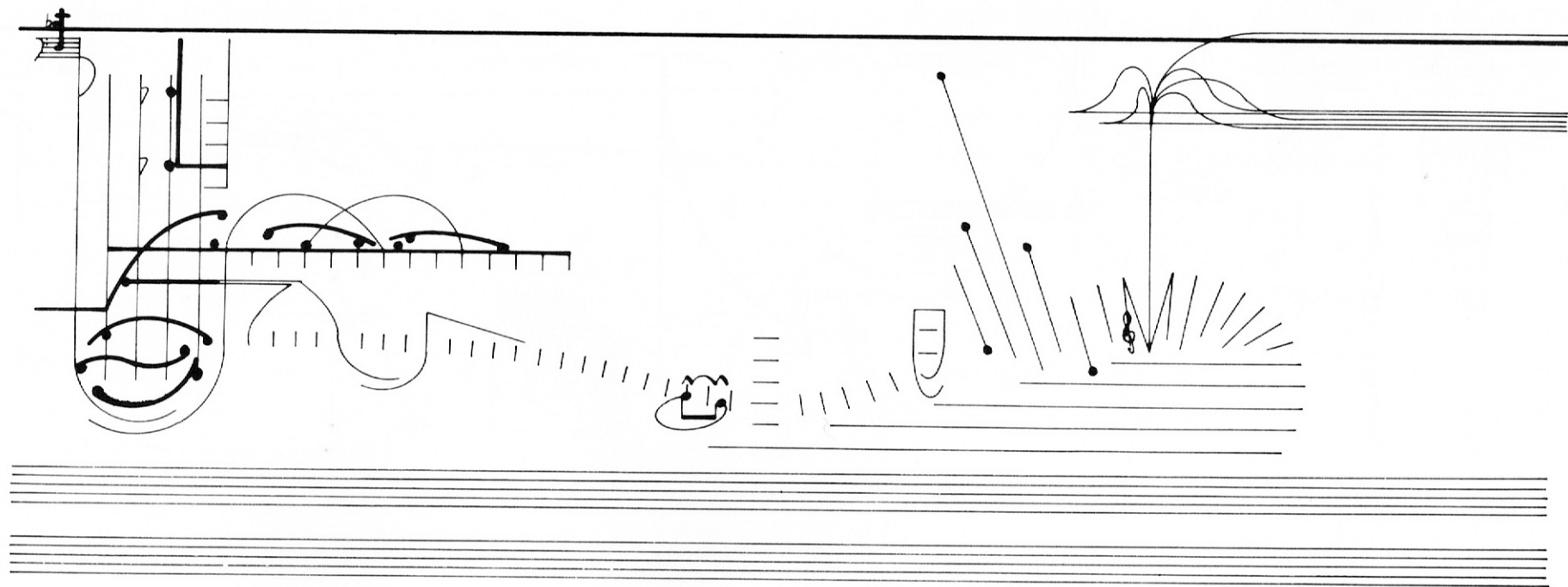
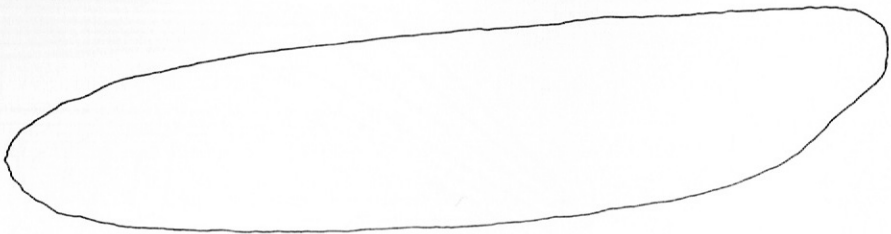

This musical score is oriented vertically on the page. It features a prominent horizontal line that spans the width of the page. Below this line, a large, sweeping curve descends from the left side, crosses the horizontal line, and then rises back up to the right. To the left of this curve, there are several musical notations: a treble clef, a sharp sign (#), and a circled section containing a treble clef and a few notes. To the right of the curve, there are two circled sections, each containing a treble clef and a sharp sign. The number '1' is written below the first circle, and the number '2' is written below the second circle. The overall layout is complex and abstract, with a focus on the relationship between the horizontal line and the curved line.

Two sets of empty musical staves, each consisting of five lines, are positioned at the bottom of the page. They are arranged horizontally and are completely blank, with no musical notation or markings.

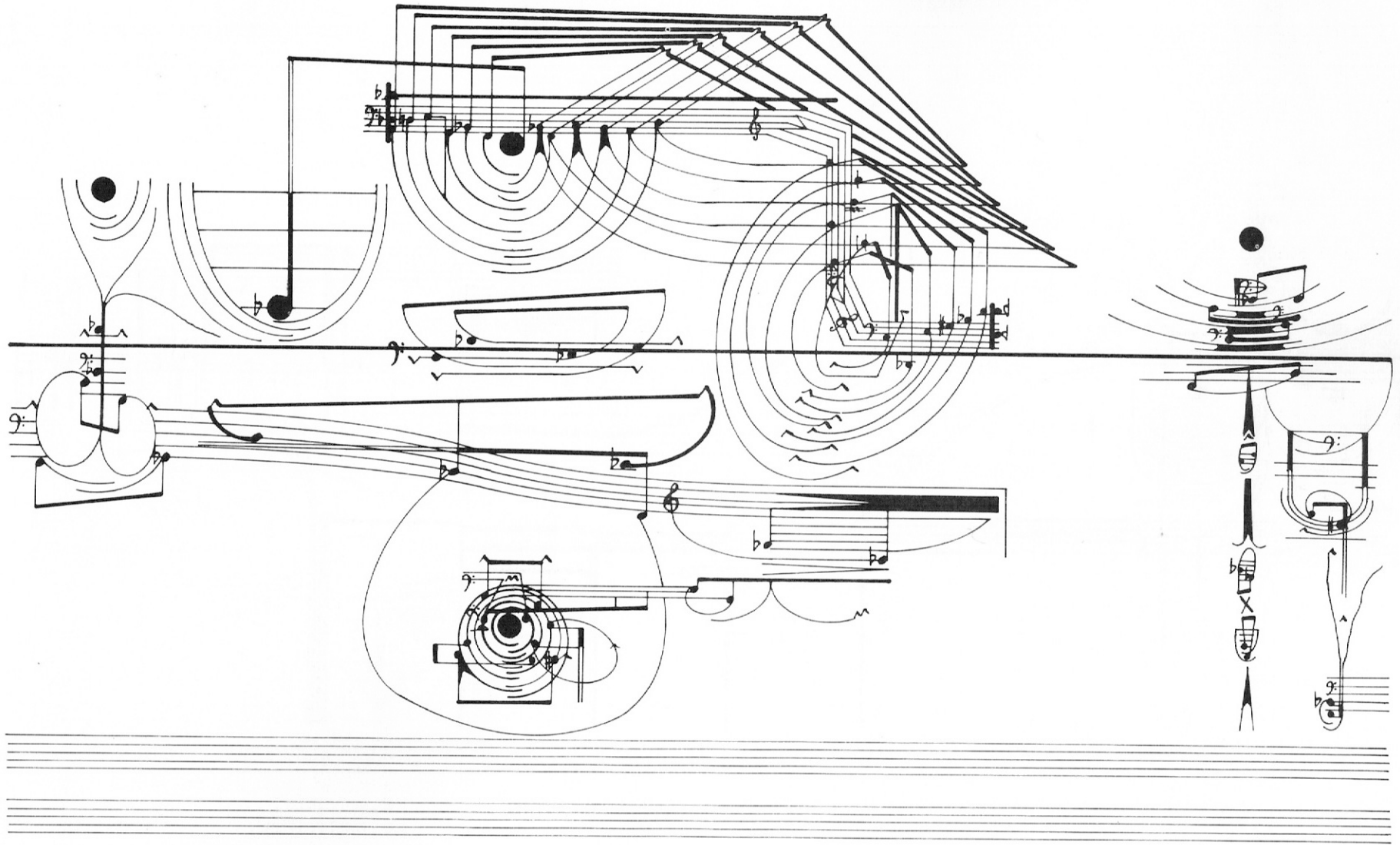

Handwritten musical score on a page with a binder edge on the right. The score consists of several staves. The top staff has a treble clef and contains a complex melodic line with many beamed notes. Below it are two staves with a common clef, showing a similar melodic line. The bottom section of the page features two empty staves. The right edge of the page shows the metal rings of a binder.

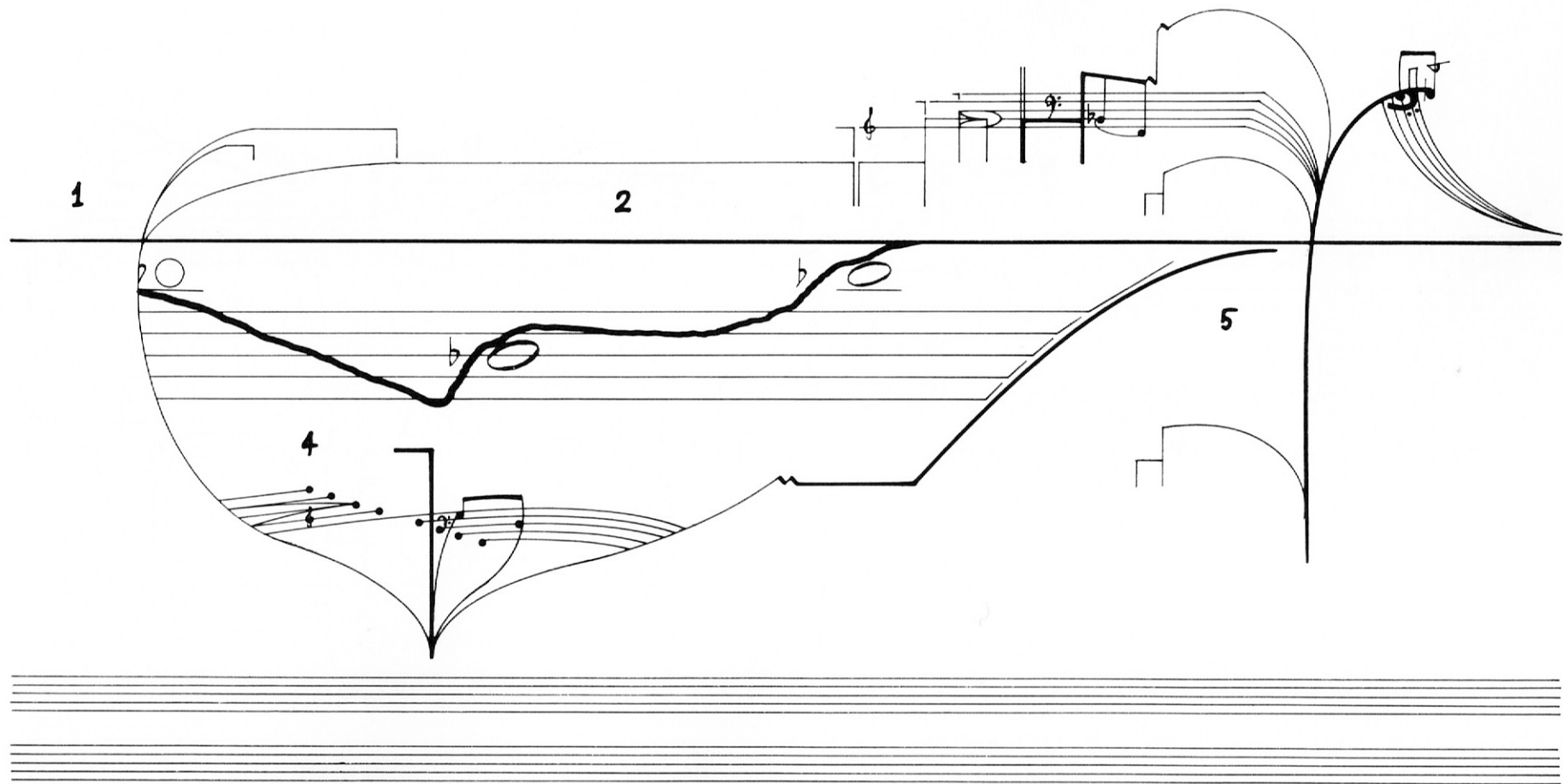

Handwritten musical score on a page with a binder edge on the right. The score consists of several staves. The top staff has a treble clef and contains a melodic line with notes, rests, and a sharp sign. Below it are two more staves with musical notation, including a circled note. At the bottom, there are two empty staves. The page number 186 is visible in the bottom left corner.

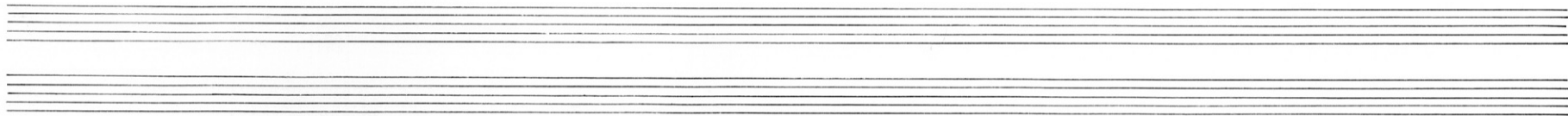
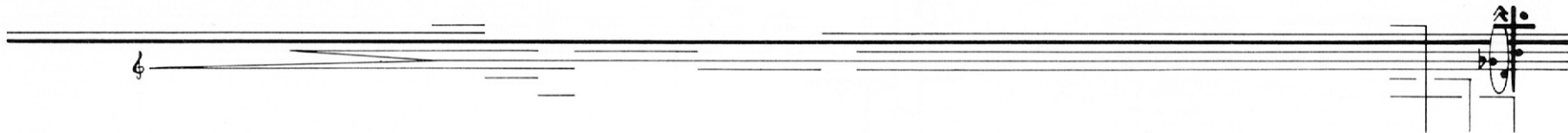

A musical score on a single staff. The upper portion of the staff contains a complex melodic line with multiple overlapping lines, suggesting a tremolo or a multi-measure rest. A vertical line is drawn through this section, with the number '3' positioned above it. Below the staff, there are several vertical lines and a curved line, with the number '1' positioned below the first vertical line. To the right, the staff continues with a melodic line featuring a treble clef, a key signature of one flat (B-flat), and a common time signature (C). The notes include a quarter note, an eighth note, and a sixteenth note. A vertical line is drawn through this section, with the number '3' positioned to its right. The lower portion of the staff is empty.

A handwritten musical score on a single staff. The notation includes several horizontal lines of varying lengths, some with vertical stems. A vertical bar line is present. To the right of the bar line, there is a circled section with a vertical line through it, and a note with a stem. Below the staff, there are handwritten numbers: '3', '6', and a circled '3'. A thick, dark, wavy line is drawn above the staff on the right side.

Two sets of empty musical staves, each consisting of five horizontal lines, positioned below the main notation.

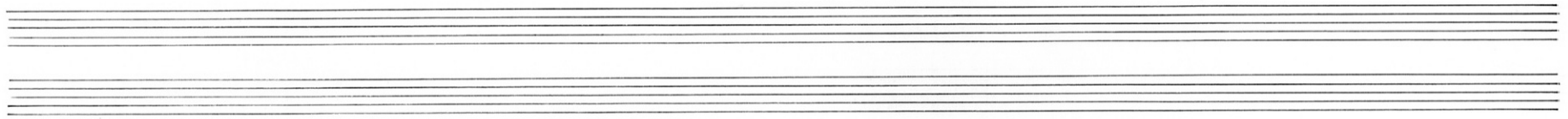
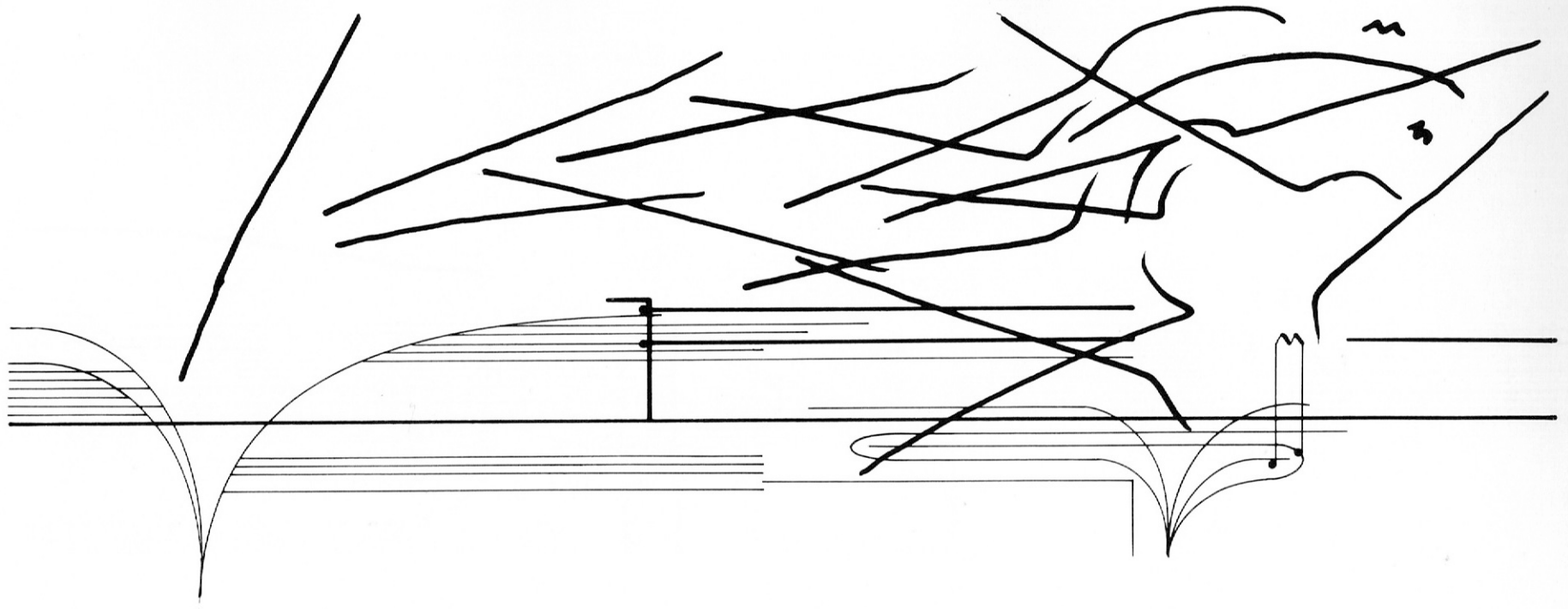

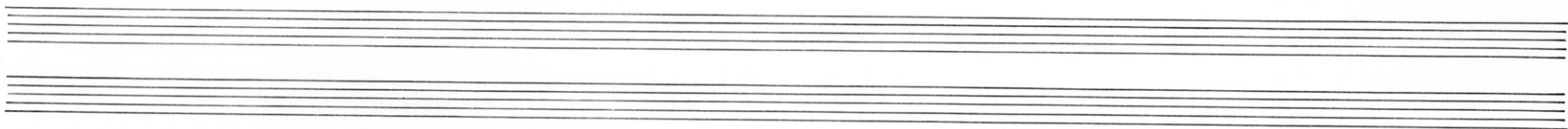
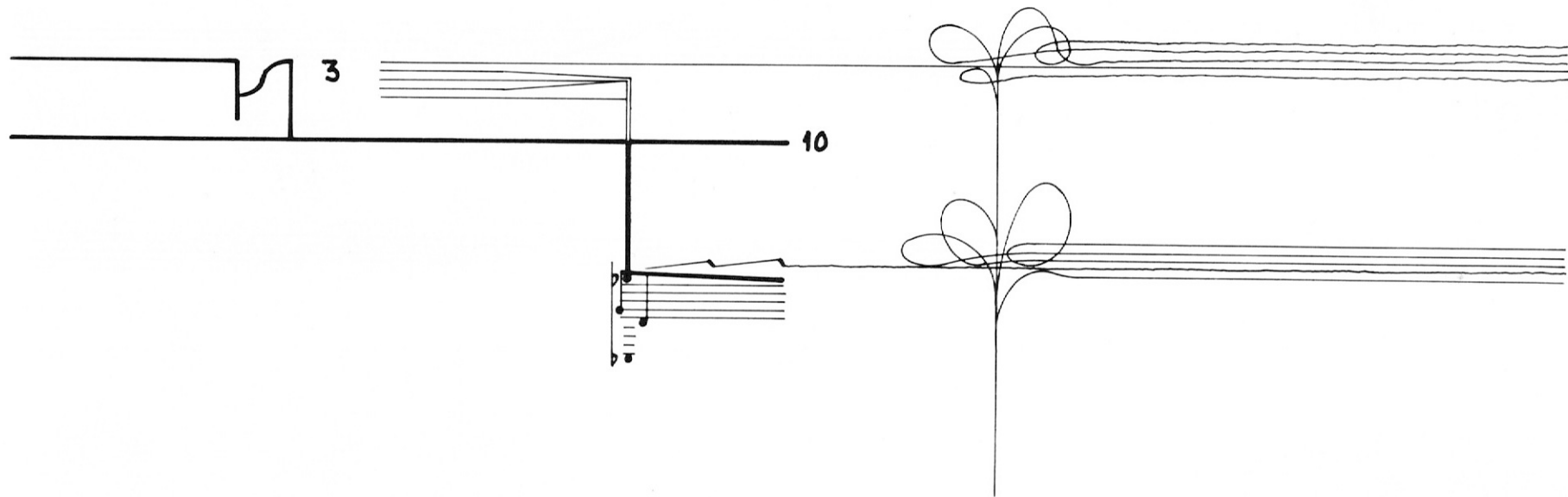

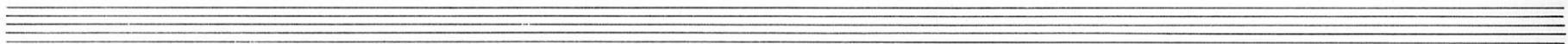
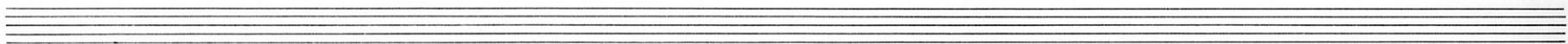
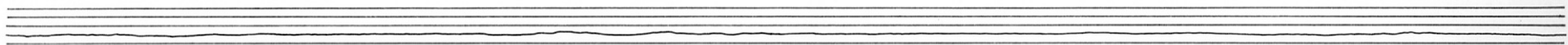

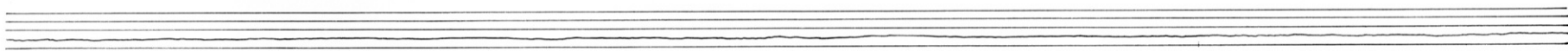
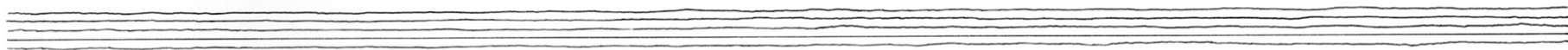

1963-67

